

ROBOTICS

# Product manual

## IRB 4600 Foundry Prime



Trace back information:  
Workspace 22B version a4  
Checked in 2022-06-01  
Skribenta version 5.5.019

**Product manual**  
**IRB 4600 Foundry Prime - 60/2.05**

IRC5, OmniCore

Document ID: 3HAC040585-001

Revision: U

The information in this manual is subject to change without notice and should not be construed as a commitment by ABB. ABB assumes no responsibility for any errors that may appear in this manual.

Except as may be expressly stated anywhere in this manual, nothing herein shall be construed as any kind of guarantee or warranty by ABB for losses, damage to persons or property, fitness for a specific purpose or the like.

In no event shall ABB be liable for incidental or consequential damages arising from use of this manual and products described herein.

This manual and parts thereof must not be reproduced or copied without ABB's written permission.

Keep for future reference.

Additional copies of this manual may be obtained from ABB.

Original instructions.

© Copyright 2013-2022 ABB. All rights reserved.  
Specifications subject to change without notice.



# Table of contents

Overview of this manual .....	9
Product documentation .....	14
How to read the product manual .....	16
Important information about robots with protection type Foundry Prime .....	17
<b>1 Safety</b> .....	<b>19</b>
1.1 Safety information .....	19
1.1.1 Limitation of liability .....	19
1.1.2 Requirements on personnel .....	20
1.2 Safety signals and symbols .....	21
1.2.1 Safety signals in the manual .....	21
1.2.2 Safety symbols on manipulator labels .....	23
1.3 Robot stopping functions .....	29
1.4 Safety during installation and commissioning .....	30
1.5 Safety during operation .....	33
1.6 Safety during maintenance and repair .....	34
1.6.1 Safety during maintenance and repair .....	34
1.6.2 Emergency release of the robot axes .....	37
1.6.3 Brake testing .....	38
1.7 Safety during troubleshooting .....	39
1.8 Safety during decommissioning .....	40
<b>2 Installation and commissioning</b> .....	<b>41</b>
2.1 Introduction to installation and commissioning .....	41
2.2 Installation and operational requirements for Foundry Prime robots .....	42
2.2.1 Shut-down periods .....	46
2.3 Unpacking .....	47
2.3.1 Pre-installation procedure .....	47
2.3.2 Surface inspection before start-up - Foundry Prime .....	51
2.3.3 Working range and type of motion .....	52
2.3.4 Risk of tipping/stability .....	55
2.3.5 The unit is sensitive to ESD .....	56
2.4 On-site installation .....	57
2.4.1 Lifting robot with roundslings .....	57
2.4.2 Lifting and turning a suspended mounted robot .....	60
2.4.3 Setting the system parameters for a suspended or tilted robot .....	61
2.4.4 Manually releasing the brakes .....	65
2.4.5 Orienting and securing the robot .....	68
2.4.6 Fitting equipment on robot .....	72
2.4.7 Surface inspection before start-up - Foundry Prime .....	79
2.4.8 Loads fitted to the robot, stopping time and braking distances .....	80
2.4.9 Installation of signal lamp (option) .....	81
2.5 Restricting the working range .....	82
2.5.1 Axes with restricted working range .....	82
2.5.2 Mechanically restricting the working range of axis 1 .....	83
2.6 Installing options .....	86
2.6.1 Installing an expansion container .....	86
2.7 Robot in hot environments .....	91
2.7.1 Start of robot in hot environments .....	91
2.8 Robot in cold environments .....	92
2.8.1 Start of robot in cold environments .....	92
2.9 Electrical connections .....	93
2.9.1 Robot cabling and connection points .....	93
2.9.2 Customer connection on robot .....	96
2.10 Additional installation (Foundry Prime) .....	102
2.10.1 Installation of IRB 4600 Foundry Prime in a water jet application .....	102

## Table of contents

---

2.10.2	Commissioning (Foundry Prime) .....	106
2.11	Test run after installation, maintenance, or repair .....	107
<b>3</b>	<b>Maintenance</b> .....	<b>109</b>
3.1	Introduction .....	109
3.2	Introduction for Foundry Prime robots .....	110
3.3	Maintenance schedule .....	111
3.3.1	Specification of maintenance intervals .....	111
3.3.2	Maintenance schedule .....	112
3.3.3	Expected component life .....	114
3.4	Inspection activities .....	115
3.4.1	Inspecting oil level, axis 1 gearbox .....	115
3.4.2	Inspecting the oil level, axis 2 gearbox .....	121
3.4.3	Inspecting the oil level, axis 3 gearbox .....	124
3.4.4	Inspecting the oil level, axis 4 gearbox .....	126
3.4.5	Inspecting oil level, gearbox axes 5 - 6 .....	128
3.4.6	Inspecting the cable harness .....	132
3.4.7	Inspecting information labels .....	134
3.4.8	Inspecting the mechanical stop pin, axis 1 .....	136
3.4.9	Inspecting additional mechanical stops .....	139
3.4.10	Inspecting dampers .....	141
3.4.11	Inspecting the leak proof o-ring and pressure relief valves .....	143
3.4.12	Inspecting Signal lamp (option) .....	146
3.4.13	Inspection of air hoses (Foundry Prime) .....	148
3.4.14	Inspection of surface treatment (Foundry Prime) .....	150
3.5	Replacement activities .....	151
3.5.1	Type of lubrication in gearboxes .....	151
3.5.2	Changing the oil, axis 1 gearbox on floor mounted robots .....	153
3.5.3	Changing the oil, axis-1 gearbox on suspended robots .....	160
3.5.4	Changing the oil, axis-2 gearbox .....	165
3.5.5	Changing the oil, axis-3 gearbox .....	169
3.5.6	Changing the oil, axis-4 gearbox .....	175
3.5.7	Changing oil, axes-5 and -6 gearboxes .....	179
3.5.8	Replacing SMB battery .....	183
3.6	Analysis activities .....	188
3.6.1	Analyzing the water content in gearbox oil .....	188
3.7	Cleaning activities .....	189
3.7.1	Cleaning the IRB 4600 Foundry Prime .....	189
<b>4</b>	<b>Repair</b> .....	<b>193</b>
4.1	Introduction .....	193
4.2	General procedures .....	194
4.2.1	Performing a leak-down test .....	194
4.2.2	Mounting instructions for bearings .....	195
4.2.3	Mounting instructions for sealings .....	197
4.2.4	Cut the paint or surface on the robot before replacing parts .....	200
4.2.5	The brake release buttons may be jammed after service work .....	202
4.3	Complete robot .....	203
4.3.1	Removing the complete cable harness .....	203
4.3.2	Refitting the complete cable harness .....	216
4.3.3	Replacement of air nipples and hoses (Foundry Prime) .....	232
4.3.4	Replacing SMB unit .....	244
4.3.5	Replacing the brake release board .....	251
4.3.6	Replacing the base .....	256
4.4	Upper arm .....	266
4.4.1	Replacing the complete upper arm .....	266
4.4.2	Replacing complete tubular shaft unit .....	276
4.4.3	Replacing wrist unit .....	283
4.4.4	Measuring the play, axis 5 .....	289

4.4.5	Measuring the play, axis 6 .....	291
4.5	Lower arm .....	294
4.5.1	Replacing the lower arm .....	294
4.6	Frame and base .....	300
4.6.1	Replacing stop pin axis 1 .....	300
4.7	Motors .....	304
4.7.1	Removing motors .....	304
4.7.2	Refitting motors .....	313
4.7.3	Adjusting the play of axis 4, 5 and 6 motors .....	324
4.8	Gearboxes .....	325
4.8.1	Replacing gearbox axis 1 .....	325
4.8.2	Replacing gearbox axis 2 .....	335
4.8.3	Replacing gearbox axis 3 .....	344
<b>5</b>	<b>Calibration</b> .....	<b>353</b>
5.1	Introduction to calibration .....	353
5.1.1	Introduction and calibration terminology .....	353
5.1.2	Calibration methods .....	354
5.1.3	When to calibrate .....	357
5.2	Synchronization marks and axis movement directions .....	358
5.2.1	Synchronization marks and synchronization position for axes .....	358
5.2.2	Calibration movement directions for all axes .....	360
5.3	Updating revolution counters .....	361
5.3.1	Updating revolution counters on IRC5 robots .....	361
5.3.2	Updating revolution counters on OmniCore robots .....	365
5.4	Calibrating with Axis Calibration method .....	367
5.4.1	Description of Axis Calibration .....	367
5.4.2	Calibration tools for Axis Calibration .....	370
5.4.3	Installation locations for the calibration tools .....	372
5.4.4	Axis Calibration - Running the calibration procedure .....	374
5.4.5	Reference calibration .....	379
5.5	Calibrating with Calibration Pendulum method .....	381
5.6	Calibrating with Wrist Optimization method .....	382
5.7	Verifying the calibration .....	384
5.8	Checking the synchronization position .....	385
<b>6</b>	<b>Decommissioning</b> .....	<b>387</b>
6.1	Introduction to decommissioning .....	387
6.2	Environmental information .....	388
6.3	Scrapping of robot .....	390
<b>7</b>	<b>Reference information</b> .....	<b>391</b>
7.1	Introduction .....	391
7.2	Applicable standards .....	392
7.3	Unit conversion .....	393
7.4	Screw joints .....	394
7.5	Weight specifications .....	397
7.6	Standard tools .....	398
7.7	Special tools .....	399
7.8	Lifting accessories and lifting instructions .....	402
<b>8</b>	<b>Spare part lists</b> .....	<b>403</b>
8.1	Spare part lists and illustrations .....	403
<b>9</b>	<b>Circuit diagram</b> .....	<b>405</b>
9.1	Circuit diagrams .....	405
<b>Index</b>		<b>407</b>

**This page is intentionally left blank**

# Overview of this manual

---

## About this manual

This manual contains instructions for:

- mechanical and electrical installation of the IRB 4600 Foundry Prime
- maintenance of the IRB 4600 Foundry Prime
- mechanical and electrical repair of the IRB 4600 Foundry Prime

The robot described in this manual has the following protection types:

- *Foundry Prime*

This manual describes the manipulator using either the IRC5 or the OmniCore controller.

---

## Product manual scope

The manual covers all variants and designs of the IRB 4600 Foundry Prime. Some variants and designs may have been removed from the business offer and are no longer available for purchase.

---

## Usage

This manual should be used during:

- installation and commissioning, from lifting the product to its work site and securing it to the foundation, to making it ready for operation
- maintenance work
- repair work
- decommissioning work



### Note

It is the responsibility of the integrator to conduct a risk assessment of the final application.

It is the responsibility of the integrator to provide safety and user guides for the robot system.

---

## Who should read this manual?

This manual is intended for:

- installation personnel
  - maintenance personnel
  - repair personnel.
- 

## Prerequisites

A maintenance/repair/installation craftsman working with an ABB robot must:

- be trained by ABB and have the required knowledge of mechanical and electrical installation/repair/maintenance work.
  - be trained to respond to emergencies or abnormal situations.
- 

*Continues on next page*

## References

Reference	Document ID
<i>Product manual - IRB 4600</i>	3HAC033453-001
<i>Product manual, spare parts - IRB 4600</i>	3HAC049108-001
<i>Circuit diagram - IRB 4600</i>	3HAC029038-003
<i>Technical reference manual - Lubrication in gearboxes</i>	3HAC042927-001
<i>Product specification - IRB 4600</i> For OmniCore robots	3HAC080366-001
<i>Product specification - IRB 4600</i> For IRC5 robots	3HAC032885-001
<i>Safety manual for robot - Manipulator and IRC5 or OmniCore controller</i> <sup>i</sup>	3HAC031045-001
<i>Product manual - OmniCore V250XT</i> For OmniCore robots	3HAC073447-001
<i>Product manual - IRC5</i> For IRC5 robots, with main computer DSQC 639.	3HAC021313-001
<i>Product manual - IRC5</i> For IRC5 robots, with main computer DSQC1000.	3HAC047136-001
<i>Operating manual - Emergency safety information</i>	3HAC027098-001
<i>Operating manual - OmniCore</i>	3HAC065036-001
<i>Operating manual - IRC5 with FlexPendant</i>	3HAC050941-001
<i>Operating manual - Calibration Pendulum</i> For IRC5 robots	3HAC16578-1
<i>Operating manual - Service Information System (IRC5) or Operating manual - OmniCore</i> For IRC5 robots	3HAC050944-001 (IRC5) or Operating manual - OmniCore
<i>Technical reference manual - System parameters</i> For OmniCore robots	3HAC065041-001
<i>Technical reference manual - System parameters</i> For IRC5 robots	3HAC050948-001
<i>Application manual - Additional axes and stand alone controller (IRC5)</i> For IRC5 robots	3HAC051016-001 (IRC5)
<i>Application manual - Electronic Position Switches</i> For IRC5 robots	3HAC050996-001
<i>Application manual - CalibWare Field</i> For IRC5 robots	3HAC030421-001
List of approved cleaners and detergents for Foundry Prime robots	Contact ABB local sales organization

<sup>i</sup> This manual contains all safety instructions from the product manuals for the manipulators and the controllers.

Revisions

Revision	Description
-	First edition
A	The following updates have been made in this revision: <ul style="list-style-type: none"> <li>• A new SMB unit and battery is introduced, with longer battery lifetime.</li> <li>• Updated the list of approved detergents, see <a href="#">Approved cleaners and detergents on page 191</a>.</li> </ul>
B	The following updates have been made in this revision: <ul style="list-style-type: none"> <li>• Several more spare part numbers are corrected throughout the spare part chapter.</li> <li>• The list of approved cleaners and detergents is updated more frequently than the manual is updated, therefore the information is removed from the manual and instead referenced. See <a href="#">Approved cleaners and detergents on page 191</a>.</li> </ul>
C	The following updates have been made in this revision: <ul style="list-style-type: none"> <li>• Added information about risks when scrapping a decommissioned robot, see <a href="#">Scrapping of robot on page 390</a>.</li> </ul>
D	The following updates have been made in this revision: <ul style="list-style-type: none"> <li>• Illustration changes in <a href="#">Dimension, mounting surface and guide bushing on page 69</a>.</li> <li>• Term "Guide sleeves" changed to "Guide bushings", see <a href="#">Dimension, mounting surface and guide bushing on page 69</a>.</li> <li>• A new <b>WARNING!</b> is added in the section about motor replacement, informing not to mix different motor types.</li> <li>• Minor corrections.</li> </ul>
E	The following updates have been made in this revision: <ul style="list-style-type: none"> <li>• Note added in Fitting equipment on robot.</li> <li>• Foundry Prime: Seal armhouse cover with Sikaflex (several updates)</li> </ul>
F	The following updates have been made in this revision: <ul style="list-style-type: none"> <li>• Turning disc fixture is removed from special tools for Levelmeter calibration.</li> <li>• New illustrations for foundry prime air connections in manipulator base, maintenance and repair chapter.</li> </ul>
G	Published in release R16.2. The following updates are made in this revision: <ul style="list-style-type: none"> <li>• Corrections due to updates in terminology.</li> <li>• New dimensional drawing of the turning disk added to <a href="#">Fitting equipment on wrist and mounting flange on page 77</a>.</li> <li>• New standard calibration method is introduced (Axis Calibration). See <a href="#">Calibration on page 353</a>.</li> <li>• Information about grounding point added. See <a href="#">Robot cabling and connection points on page 93</a>.</li> <li>• The spare part lists are removed from this manual. Valid spare part lists are published in <i>Product manual, spare parts - IRB 4600</i>.</li> <li>• The maintenance schedule is revised, activities not valid for IRB 4600 were incorrectly added to the schedule previously. Faulty activities are removed.</li> </ul>
H	Published in release R17.1. The following updates are made in this revision: <ul style="list-style-type: none"> <li>• Drying time for Mercasol added.</li> <li>• Changed the tightening torque of the oil plug located on axis-1 gear-box.</li> <li>• Added information regarding tightening of protective calibration plugs after calibration. Risk of damage on sealing washer if tightened too hard.</li> </ul>

Continues on next page

Revision	Description
J	<p>Published in release R17.2. The following updates are made in this revision:</p> <ul style="list-style-type: none"> <li>• Information about coupled axes in <a href="#">Updating revolution counters on IRC5 robots on page 361</a>.</li> <li>• Caution about removing metal residues added in sections about SMB boards.</li> <li>• Information about minimum resonance frequency added.</li> <li>• Bending radius for static floor cables added.</li> <li>• Updated list of applicable standards.</li> <li>• Article number for the Calibration tool box, Axis Calibration is changed.</li> <li>• Added text regarding overhaul in section specification of maintenance intervals.</li> <li>• Updated the section <a href="#">Start of robot in cold environments on page 92</a>.</li> <li>• Updated information regarding replacement of brake release board.</li> <li>• Updated information about leak proof o-ring/pressure relief valve.</li> <li>• Definition of reference calibration clarified.</li> </ul>
K	<p>Published in release R18.1. The following updates are made in this revision:</p> <ul style="list-style-type: none"> <li>• Information added about fatigue to Axis Calibration tool, see <a href="#">Calibration tools for Axis Calibration on page 370</a>.</li> <li>• Added sections in <a href="#">General procedures on page 194</a>.</li> <li>• Updated figure of axis-6 synchronization mark.</li> <li>• Updated <a href="#">Activities and intervals, Foundry Prime on page 112</a> and Oil in axis-5 &amp; -6 gearbox.</li> <li>• New spare parts numbers for brake release boards.</li> <li>• Note added to calibration chapter to emphasize the requirement of equally dressed robot when using previously created reference calibration values.</li> <li>• Information about myABB Business Portal added.</li> <li>• Added Nickel in Environmental information.</li> </ul>
L	<p>Published in release R18.2. The following updates are made in this revision:</p> <ul style="list-style-type: none"> <li>• Updates related to mechanical stop pin.</li> <li>• Changed the method for replacing the axis-1 gearbox and the base.</li> </ul>
M	<p>Published in release R18.2. The following updates are made in this revision:</p> <ul style="list-style-type: none"> <li>• Updated references.</li> </ul>
N	<p>Published in release 19B. The following updates are made in this revision:</p> <ul style="list-style-type: none"> <li>• New touch up color Graphite White available. See <a href="#">Cut the paint or surface on the robot before replacing parts on page 200</a>.</li> <li>• New article numbers for manipulator cables in section <a href="#">Robot cabling and connection points on page 93</a>.</li> <li>• Added spare parts for wrist and sealing for IRB 4600 -20/2.50. See <a href="#">Replacing wrist unit on page 283</a>.</li> <li>•</li> </ul>
P	<p>Published in release 19D. The following updates are made in this revision:</p> <ul style="list-style-type: none"> <li>• Note added about the need to calibrate if the robot is other than floor mounted. See <a href="#">When to calibrate on page 357</a>.</li> </ul>



Revision	Description
Q	<p>Published in release 20B. The following updates are made in this revision:</p> <ul style="list-style-type: none"> <li>• Clarified and added information in mounting instructions for rotating sealings, see <a href="#">Mounting instructions for sealings on page 197</a>.</li> <li>• Clarified text about position of robot and added table with dependencies between axes during Axis Calibration.</li> <li>• Article number of Calibration tool box, Axis Calibration is changed from 3HAC062326-001 to 3HAC074119-001.</li> <li>• Replaced article number and name of grease, previously 3HAB3537-1.</li> <li>• Added information about Wrist Optimization in calibration chapter.</li> </ul>
R	<p>Published in release 20C. The following updates are made in this revision:</p> <ul style="list-style-type: none"> <li>• Added note about differences in type of oil pre-filled in axis-4 gear compared to recommended oil for field maintenance.</li> <li>• Updated section about customer connections in regard to Ethernet etc. See <a href="#">Customer connection on robot on page 96</a>.</li> </ul>
S	<p>Published in release 21B. The following updates are made in this revision:</p> <ul style="list-style-type: none"> <li>• New cable bracket. See <a href="#">Location of axis-3, axis-4, axis-5 and axis-6 motors on page 305</a>.</li> <li>• Text regarding fastener quality is updated, see <a href="#">Fastener quality on page 78</a>.</li> </ul>
T	<p>Published in release 21D. The following updates are made in this revision:</p> <ul style="list-style-type: none"> <li>• Added information for the OmniCore robot controller.</li> </ul>
U	<p>Published in release 22B. The following updates are done in this revision:</p> <ul style="list-style-type: none"> <li>• Updated information about Gleitmo treated screws, see <a href="#">Screw joints on page 394</a>.</li> <li>• Updated manipulator weight.</li> </ul>

# Product documentation

---

### Categories for user documentation from ABB Robotics

The user documentation from ABB Robotics is divided into a number of categories. This listing is based on the type of information in the documents, regardless of whether the products are standard or optional.



#### Tip

All documents can be found via myABB Business Portal, [www.abb.com/myABB](http://www.abb.com/myABB).

---

### Product manuals

Manipulators, controllers, DressPack/SpotPack, and most other hardware is delivered with a **Product manual** that generally contains:

- Safety information.
- Installation and commissioning (descriptions of mechanical installation or electrical connections).
- Maintenance (descriptions of all required preventive maintenance procedures including intervals and expected life time of parts).
- Repair (descriptions of all recommended repair procedures including spare parts).
- Calibration.
- Decommissioning.
- Reference information (safety standards, unit conversions, screw joints, lists of tools).
- Spare parts list with corresponding figures (or references to separate spare parts lists).
- References to circuit diagrams.

---

### Technical reference manuals

The technical reference manuals describe reference information for robotics products, for example lubrication, the RAPID language, and system parameters.

---

### Application manuals

Specific applications (for example software or hardware options) are described in **Application manuals**. An application manual can describe one or several applications.

An application manual generally contains information about:

- The purpose of the application (what it does and when it is useful).
- What is included (for example cables, I/O boards, RAPID instructions, system parameters, software).
- How to install included or required hardware.
- How to use the application.
- Examples of how to use the application.

*Continues on next page*

---

**Operating manuals**

The operating manuals describe hands-on handling of the products. The manuals are aimed at those having first-hand operational contact with the product, that is production cell operators, programmers, and troubleshooters.

# How to read the product manual

---

### Reading the procedures

The procedures contain references to figures, tools, material, and so on. The references are read as described below.

### References to figures

The procedures often include references to components or attachment points located on the manipulator/controller. The components or attachment points are marked with *italic text* in the procedures and completed with a reference to the figure where the current component or attachment point is shown.

The denomination in the procedure for the component or attachment point corresponds to the denomination in the referenced figure.

The table below shows an example of a reference to a figure from a step in a procedure.

	Action	Note/Illustration
8.	Remove the <i>rear attachment screws, gearbox</i> .	Shown in the figure <a href="#">Location of gearbox on page xx</a> .

### References to required equipment

The procedures often include references to equipment (spare parts, tools, etc.) required for the different actions in the procedure. The equipment is marked with *italic text* in the procedures and completed with a reference to the section where the equipment is listed with further information, that is article number and dimensions.

The designation in the procedure for the component or attachment point corresponds to the designation in the referenced list.

The table below shows an example of a reference to a list of required equipment from a step in a procedure.

	Action	Note/Illustration
3.	Fit a new <i>sealing, axis 2</i> to the gearbox.	Art. no. is specified in <a href="#">Required equipment on page xx</a> .

### Safety information

The manual includes a separate safety chapter that must be read through before proceeding with any service or installation procedures. All procedures also include specific safety information when dangerous steps are to be performed.

Read more in the chapter [Safety on page 19](#).

### Illustrations

The robot is illustrated with general figures that does not take painting or protection type in consideration.

Likewise, certain work methods or general information that is valid for several robot models, can be illustrated with illustrations that show a different robot model than the one that is described in the current manual.

# Important information about robots with protection type Foundry Prime

---

## Introduction

Foundry Prime robots are specially designed to work in harsh environments. Misuse of the robots or poor installation, cleaning, maintenance and repair can be harmful for the functioning of the robot.

---

## Warranty claims

Warranty claims for defect products due to misuse or failure to fulfil operational and maintenance requirements will not be approved.

---

## Pressurized components

Motors, balancing device and the serial measurement board cavity shall be pressurized on Foundry Prime robots during operation and shut down. The overpressure can be dropped when atmospheric humidity has reached the same level as the surrounding environment.

For more information, see [Pressurized components on page 42](#).

---

## Cleaning

Special procedures are needed when cleaning the Foundry Prime robot. See section [Cleaning the IRB 4600 Foundry Prime on page 189](#).

**This page is intentionally left blank**

# 1 Safety

## 1.1 Safety information

### 1.1.1 Limitation of liability

---

#### Limitation of liability

Any information given in this manual regarding safety must not be construed as a warranty by ABB that the industrial robot will not cause injury or damage even if all safety instructions are complied with.

The information does not cover how to design, install and operate a robot system, nor does it cover all peripheral equipment that can influence the safety of the robot system.

In particular, liability cannot be accepted if injury or damage has been caused for any of the following reasons:

- Use of the robot in other ways than intended.
- Incorrect operation or maintenance.
- Operation of the robot when the safety devices are defective, not in their intended location or in any other way not working.
- When instructions for operation and maintenance are not followed.
- Non-authorized design modifications of the robot.
- Repairs on the robot and its spare parts carried out by in-experienced or non-qualified personnel.
- Foreign objects.
- Force majeure.

---

#### Spare parts and equipment

ABB supplies original spare parts and equipment which have been tested and approved. The installation and/or use of non-original spare parts and equipment can negatively affect the safety, function, performance, and structural properties of the robot. ABB is not liable for damages caused by the use of non-original spare parts and equipment.

# 1 Safety

---

## 1.1.2 Requirements on personnel

### 1.1.2 Requirements on personnel

---

#### General

Only personnel with appropriate training are allowed to install, maintain, service, repair, and use the robot. This includes electrical, mechanical, hydraulics, pneumatics, and other hazards identified in the risk assessment.

Persons who are under the influence of alcohol, drugs or any other intoxicating substances are not allowed to install, maintain, service, repair, or use the robot.

The plant liable must make sure that the personnel is trained on the robot, and on responding to emergency or abnormal situations.

---

#### Personal protective equipment

Use personal protective equipment, as stated in the instructions.



## 1.2 Safety signals and symbols

### 1.2.1 Safety signals in the manual







#### Introduction to safety signals

This section specifies all safety signals used in the user manuals. Each signal consists of:

- A caption specifying the hazard level (DANGER, WARNING, or CAUTION) and the type of hazard.
- Instruction about how to reduce the hazard to an acceptable level.
- A brief description of remaining hazards, if not adequately reduced.

#### Hazard levels

The table below defines the captions specifying the hazard levels used throughout this manual.

Symbol	Designation	Significance
	DANGER	Signal word used to indicate an imminently hazardous situation which, if not avoided, will result in serious injury.
	WARNING	Signal word used to indicate a potentially hazardous situation which, if not avoided, could result in serious injury.
	ELECTRICAL SHOCK	Signal word used to indicate a potentially hazardous situation related to electrical hazards which, if not avoided, could result in serious injury.
	CAUTION	Signal word used to indicate a potentially hazardous situation which, if not avoided, could result in slight injury.
	ELECTROSTATIC DISCHARGE (ESD)	Signal word used to indicate a potentially hazardous situation which, if not avoided, could result in severe damage to the product.
	NOTE	Signal word used to indicate important facts and conditions.

*Continues on next page*

# 1 Safety

---

## 1.2.1 Safety signals in the manual

*Continued*

Symbol	Designation	Significance
	TIP	Signal word used to indicate where to find additional information or how to do an operation in an easier way.

## 1.2.2 Safety symbols on manipulator labels

### Introduction to symbols

This section describes safety symbols used on labels (stickers) on the manipulator. Symbols are used in combinations on the labels, describing each specific warning. The descriptions in this section are generic, the labels can contain additional information such as values.



#### Note

The symbols on the labels on the product must be observed. Additional symbols added by the integrator must also be observed.



### Types of symbols

Both the manipulator and the controller are marked with symbols, containing important information about the product. This is important for all personnel handling the robot, for example during installation, service, or operation.

The safety labels are language independent, they only use graphics. See [Symbols on safety labels on page 23](#).

The information labels can contain information in text.

### Symbols on safety labels



Symbol	Description
 xx0900000812	<b>Warning!</b> Warns that an accident <i>may</i> occur if the instructions are not followed that can lead to serious injury, possibly fatal, and/or great damage to the product. It applies to warnings that apply to danger with, for example, contact with high voltage electrical units, explosion or fire risk, risk of poisonous gases, risk of crushing, impact, fall from height, etc.
 xx0900000811	<b>Caution!</b> Warns that an accident may occur if the instructions are not followed that can result in injury and/or damage to the product. It also applies to warnings of risks that include burns, eye injury, skin injury, hearing damage, crushing or slipping, tripping, impact, fall from height, etc. Furthermore, it applies to warnings that include function requirements when fitting and removing equipment where there is a risk of damaging the product or causing a breakdown.
 xx0900000839	<b>Prohibition</b> Used in combinations with other symbols.

*Continues on next page*



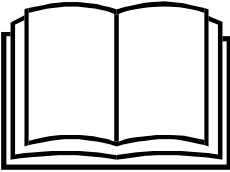
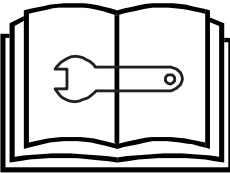
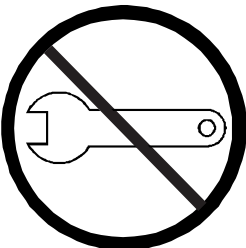
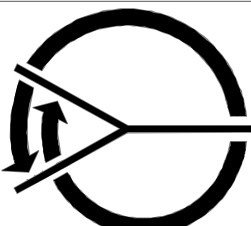

# 1 Safety

## 1.2.2 Safety symbols on manipulator labels

Continued

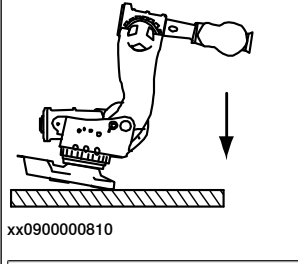
Symbol	Description
 xx0900000813	<b>See user documentation</b> Read user documentation for details. Which manual to read is defined by the symbol: <ul style="list-style-type: none"><li>• No text: <i>Product manual</i>.</li><li>• EPS: <i>Application manual - Electronic Position Switches</i>.</li></ul>
 xx0900000816	<b>Before disassembly, see product manual</b>
 xx0900000815	<b>Do not disassemble</b> Disassembling this part can cause injury.
 xx0900000814	<b>Extended rotation</b> This axis has extended rotation (working area) compared to standard.
 xx0900000808	<b>Brake release</b> Pressing this button will release the brakes. This means that the robot arm can fall down.

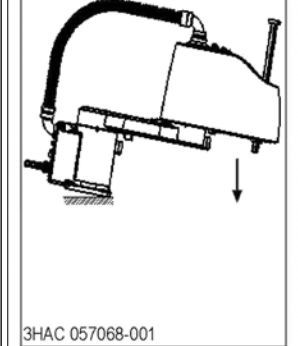

Continues on next page

Symbol	Description
 <p>xx0900000810</p>   <p>3HAC 057068-001</p> <p>xx1500002402</p>	<p><b>Tip risk when loosening bolts</b> The robot can tip over if the bolts are not securely fastened.</p>
  <p>xx0900000817</p>	<p><b>Crush</b> Risk of crush injuries.</p>





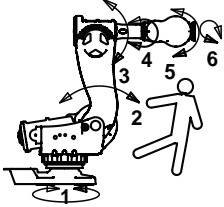
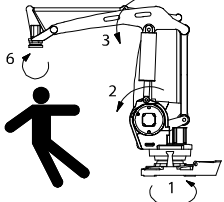
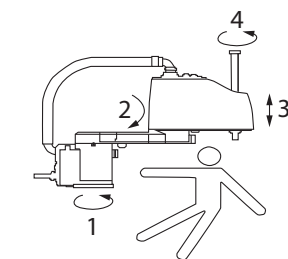

# 1 Safety

## 1.2.2 Safety symbols on manipulator labels

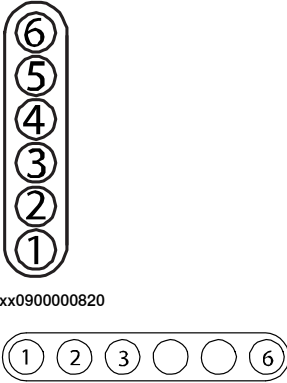
Continued

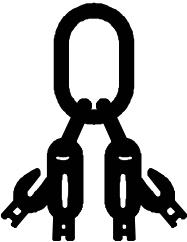
Symbol	Description
 xx0900000818  xx1300001087	<b>Heat</b> Risk of heat that can cause burns. (Both signs are used)
 xx0900000819  xx1000001141  xx1500002616	<b>Moving robot</b> The robot can move unexpectedly.

Continues on next page





Symbol	Description
 <p>xx0900000820</p> <p>xx1000001140</p>	<p><b>Brake release buttons</b></p>
 <p>xx0900000821</p>	<p><b>Lifting bolt</b></p>
 <p>xx1000001242</p>	<p><b>Chain sling with shortener</b></p>
 <p>xx0900000822</p>	<p><b>Lifting of robot</b></p>
 <p>xx0900000823</p>	<p><b>Oil</b> Can be used in combination with prohibition if oil is not allowed.</p>
 <p>xx0900000824</p>	<p><b>Mechanical stop</b></p>

Continues on next page

# 1 Safety

## 1.2.2 Safety symbols on manipulator labels

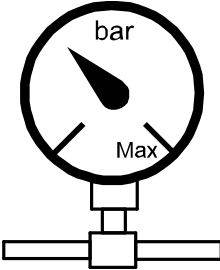
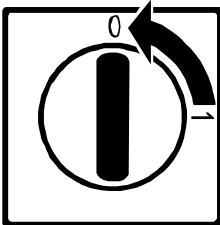
Continued

Symbol	Description
 xx1000001144	<b>No mechanical stop</b>
 xx0900000825	<b>Stored energy</b> Warns that this part contains stored energy. Used in combination with <i>Do not disassemble</i> symbol.
 xx0900000826	<b>Pressure</b> Warns that this part is pressurized. Usually contains additional text with the pressure level.
 xx0900000827	<b>Shut off with handle</b> Use the power switch on the controller.
 xx1400002648	<b>Do not step</b> Warns that stepping on these parts can cause damage to the parts.



### 1.3 Robot stopping functions

---

#### Protective stop and emergency stop

The protective stops and emergency stops are described in the product manual for the controller.

For more information see:

- *Product manual - OmniCore V250XT*
- *Product manual - IRC5*
- *Product manual - IRC5 Panel Mounted Controller*

# 1 Safety

---

## 1.4 Safety during installation and commissioning

### 1.4 Safety during installation and commissioning

---

#### National or regional regulations

The integrator of the robot system is responsible for the safety of the robot system.

The integrator is responsible that the robot system is designed and installed in accordance with the safety requirements set forth in the applicable national and regional standards and regulations.

The integrator of the robot system is required to perform a risk assessment.

---

#### Layout

The robot integrated to a robot system shall be designed to allow safe access to all spaces during installation, operation, maintenance, and repair.

If robot movement can be initiated from an external control panel then an emergency stop must also be available.

If the manipulator is delivered with mechanical stops, these can be used for reducing the working space.

A perimeter safeguarding, for example a fence, shall be dimensioned to withstand the following:

- The force of the manipulator.
- The force of the load handled by the robot if dropped or released at maximum speed.
- The maximum possible impact caused by a breaking or malfunctioning rotating tool or other device fitted to the robot.

The maximum TCP speed and the maximum velocity of the robot axes are detailed in the section *Robot motion* in the product specification for the respective manipulator.

Consider exposure to hazards, such as slipping, tripping, and falling.

Hazards due to the working position and posture for a person working with or near the robot shall be considered.

Hazards due to noise emission from the robot needs to be considered.

Consider hazards from other equipment in the robot system, for example, that guards remain active until identified hazards are reduced to an acceptable level.

---

#### Allergenic material

See [Environmental information on page 388](#) for specification of allergenic materials in the product, if any.

---

#### Securing the robot to the foundation

The robot must be properly fixed to its foundation/support, as described in the respective product manual.

When the robot is installed at a height, hanging, or other than mounted directly on the floor, there will be additional hazards.

---

*Continues on next page*

### Electrical safety

Incoming mains must be installed to fulfill national regulations.

The power supply wiring to the robot must be sufficiently fused and if necessary, it must be possible to disconnect it manually from the mains power.

The power to the robot must be turned off with the main switch and the mains power disconnected when performing work inside the controller cabinet. Lock and tag shall be considered.

Harnesses between controller and manipulator shall be fixed and protected to avoid tripping and wear.

Wherever possible, power on/off or rebooting the robot controller shall be performed with all persons outside the safeguarded space.



#### Note

Use a CARBON DIOXIDE (CO<sub>2</sub>) extinguisher in the event of a fire in the robot.

### Safety devices

The integrator is responsible for that the safety devices necessary to protect people working with the robot system are designed and installed correctly.

When integrating the robot with external devices to a robot system:

- The integrator of the robot system must ensure that emergency stop functions are interlocked in accordance with applicable standards.
- The integrator of the robot system must ensure that safety functions are interlocked in accordance with applicable standards.

### Other hazards

A robot may perform unexpected limited movement.



#### WARNING

Manipulator movements can cause serious injuries on users and may damage equipment.

The risk assessment should also consider other hazards arising from the application, such as, but not limited to:

- Water
- Compressed air
- Hydraulics

End-effector hazards require particular attention for applications which involve close human collaboration with the robot.

### Pressure relief valves

The pressure relief valve prevents too much air pressure being built up inside the robot. The air pressure must not exceed the rated limit for the manipulator, or there is a risk of personal injury and mechanical damage.

*Continues on next page*

# 1 Safety

---

## 1.4 Safety during installation and commissioning

*Continued*

Pressure relief valves must be kept clean.

---

### Pneumatic or hydraulic related hazards



#### Note

The pressure in the complete pneumatic or hydraulic systems must be released before service and maintenance.

All components in the robot system that remain pressurized after switching off the power to the robot must be marked with clearly visible drain facilities and a warning sign that indicates the hazard of stored energy.

Loss of pressure in the robot system may cause parts or objects to drop.

Dump valves should be used in case of emergency.

Shot bolts should be used to prevent tools, etc., from falling due to gravity.

All pipes, hoses, and connections have to be inspected regularly for leaks and damage. Damage must be repaired immediately.

---

### Verify the safety functions

Before the robot system is put into operation, verify that the safety functions are working as intended and that any remaining hazards identified in the risk assessment are mitigated to an acceptable level.

### 1.5 Safety during operation

#### Automatic operation

Verify the application in the operating mode manual reduced speed, before changing mode to automatic and initiating automatic operation.

#### Unexpected movement of robot arm



#### WARNING

Hazards due to the use of brake release devices and/or gravity beneath the manipulator shall be considered.

A robot may perform unexpected limited movement.



#### WARNING

Manipulator movements can cause serious injuries on users and may damage equipment.

# 1 Safety

## 1.6.1 Safety during maintenance and repair

## 1.6 Safety during maintenance and repair

### 1.6.1 Safety during maintenance and repair

#### General

Corrective maintenance must only be carried out by personnel trained on the robot. Maintenance or repair must be done with all electrical, pneumatic, and hydraulic power switched off, that is, no remaining hazards.

Hazards due to stored mechanical energy in the manipulator for the purpose of counterbalancing axes must be considered before maintenance or repair.

Never use the robot as a ladder, which means, do not climb on the controller, manipulator, including motors, or other parts. There are hazards of slipping and falling. The robot might be damaged.

Make sure that there are no loose screws, turnings, or other unexpected parts remaining after work on the robot has been performed.

When the work is completed, verify that the safety functions are working as intended.

#### Hot surfaces

Surfaces can be hot after running the robot, and touching these may result in burns. Allow the surfaces to cool down before maintenance or repair.

#### Allergic reaction

Warning	Description	Elimination/Action
 Allergic reaction	When working with lubricants there is a risk of an allergic reaction.	Make sure that protective gear like goggles and gloves are always worn.

#### Gearbox lubricants (oil or grease)

When handling oil, grease, or other chemical substances the safety information of the respective manufacturer must be observed.









#### Note

Take special care when handling hot lubricants.

Warning	Description	Elimination/Action
 Hot oil or grease	Changing and draining gearbox oil or grease may require handling hot lubricant heated up to 90 °C.	Make sure that protective gear like goggles and gloves are always worn during this activity.

*Continues on next page*

Warning	Description	Elimination/Action
 <b>Allergic reaction</b>	When working with lubricants there is a risk of an allergic reaction.	Make sure that protective gear like goggles and gloves are always worn.
 <b>Possible pressure build-up in gearbox</b>	When opening the oil or grease plug, there may be pressure present in the gearbox, causing lubricant to spray from the opening.	Open the plug carefully and keep away from the opening. Do not overfill the gearbox when filling.
 <b>Do not overfill</b>	Overfilling of gearbox lubricant can lead to internal over-pressure inside the gearbox which in turn may: <ul style="list-style-type: none"> <li>• damage seals and gaskets</li> <li>• completely press out seals and gaskets</li> <li>• prevent the robot from moving freely.</li> </ul>	Make sure not to overfill the gearbox when filling it with oil or grease. After filling, verify that the level is correct.
 <b>Do not mix types of oil</b>	Mixing types of oil may cause severe damage to the gearbox.	When filling gearbox oil, do not mix different types of oil unless specified in the instructions. Always use the type of oil specified for the product.
 <b>Heat up the oil</b>	Warm oil drains quicker than cold oil.	Run the robot before changing the gearbox oil, if possible.
 <b>Specified amount depends on drained volume</b>	The specified amount of oil or grease is based on the total volume of the gearbox. When changing the lubricant, the amount refilled may differ from the specified amount, depending on how much has previously been drained from the gearbox.	After filling, verify that the level is correct.
 <b>Contaminated oil in gearboxes</b>	For lifetime reasons always drain as much oil as possible from the gearbox. The magnetic oil plugs will gather residual metal chips.	

### Hazards related to batteries

Under rated conditions, the electrode materials and liquid electrolyte in the batteries are sealed and not exposed to the outside.

*Continues on next page*

# 1 Safety

---

## 1.6.1 Safety during maintenance and repair

*Continued*

There is a hazard in case of abuse (mechanical, thermal, electrical) which leads to the activation of safety valves and/or the rupture of the battery container. As a result under certain circumstances, electrolyte leakage, electrode materials reaction with moisture/water or battery vent/explosion/fire may follow.

Do not short circuit, recharge, puncture, incinerate, crush, immerse, force discharge or expose to temperatures above the declared operating temperature range of the product. Risk of fire or explosion.

Operating temperatures are listed in [Operating conditions, robot on page 50](#).

See safety instructions for the batteries in *Material/product safety data sheet - Battery pack (3HAC043118-001)*.

---

### Unexpected movement of robot arm



#### WARNING

Hazards due to the use of brake release devices and/or gravity beneath the manipulator shall be considered.

A robot may perform unexpected limited movement.



#### WARNING

Manipulator movements can cause serious injuries on users and may damage equipment.

---

### Related information

See also the safety information related to installation and operation.



### 1.6.2 Emergency release of the robot axes

#### Description

In an emergency situation, the brakes on a robot axis can be released manually by pushing a brake release button.

How to release the brakes is described in the section:

- [Shut-down periods on page 46.](#)

The robot may be moved manually on smaller robot models, but larger models may require using an overhead crane or similar equipment.

#### Increased injury

Before releasing the brakes, make sure that the weight of the manipulator does not result in additional hazards, for example, even more severe injuries on a trapped person.



#### **DANGER**

When releasing the holding brakes, the robot axes may move very quickly and sometimes in unexpected ways.

Make sure no personnel is near or beneath the robot.

# 1 Safety

---

## 1.6.3 Brake testing

### 1.6.3 Brake testing

---

#### When to test

During operation, the holding brake of each axis normally wears down. A test can be performed to determine whether the brake can still perform its function.

---

#### How to test

The function of the holding brake of each axis motor may be verified as described below:

- 1 Run each axis to a position where the combined weight of the manipulator and any load is maximized (maximum static load).
- 2 Switch the motor to the MOTORS OFF.
- 3 Inspect and verify that the axis maintains its position.

If the manipulator does not change position as the motors are switched off, then the brake function is adequate.



#### Note

It is recommended to run the service routine *BrakeCheck* as part of the regular maintenance, see the operating manual for the robot controller.

For robots with the option SafeMove, the *Cyclic Brake Check* routine is recommended. See the manual for SafeMove in [References on page 10](#).

## 1.7 Safety during troubleshooting

### General

When troubleshooting requires work with power switched on, special considerations must be taken:

- Safety circuits might be muted or disconnected.
- Electrical parts must be considered as *live*.
- The manipulator can move unexpectedly at any time.



#### DANGER

Troubleshooting on the controller while powered on must be performed by personnel trained by ABB or by ABB field engineers.



#### CAUTION

Risk of hot surfaces that can cause burns.

A risk assessment must be done to address both robot and robot system specific hazards.



#### WARNING

Hazards due to the use of brake release devices and/or gravity beneath the manipulator shall be considered.

A robot may perform unexpected limited movement.



#### WARNING

Manipulator movements can cause serious injuries on users and may damage equipment.

### Related information

See also the safety information related to installation, operation, maintenance, and repair.

# 1 Safety

---

## 1.8 Safety during decommissioning

### 1.8 Safety during decommissioning

---

#### General

See section [Decommissioning on page 387](#).

If the robot is decommissioned for storage, take extra precaution to reset safety devices to delivery status.

---

#### Unexpected movement of robot arm



#### WARNING

Hazards due to the use of brake release devices and/or gravity beneath the manipulator shall be considered.

A robot may perform unexpected limited movement.



#### WARNING

Manipulator movements can cause serious injuries on users and may damage equipment.

## 2 Installation and commissioning

### 2.1 Introduction to installation and commissioning

#### General

This chapter contains assembly instructions and information for installing the IRB 4600 Foundry Prime at the working site.

See also the product manual for the robot controller.

The installation must be done by qualified installation personnel in accordance with the safety requirements set forth in the applicable national and regional standards and regulations.

#### Safety information

Before any installation work is commenced, all safety information must be observed. There are general safety aspects that must be read through, as well as more specific safety information that describes the danger and safety risks when performing the procedures. Read the chapter [Safety on page 19](#) before performing any installation work.



#### Note

Always connect the IRB 4600 Foundry Prime and the robot to protective earth and residual current device (RCD) before connecting to power and starting any installation work.

For more information see:

- *Product manual - OmniCore V250XT*
- *Product manual - IRC5*
- *Product manual - IRC5 Panel Mounted Controller*

## 2 Installation and commissioning

---

### 2.2 Installation and operational requirements for Foundry Prime robots

## 2.2 Installation and operational requirements for Foundry Prime robots

---

### Introduction

Robots with protection type Foundry Prime are specially designed to work in harsh environments. To ensure that the protection offers the best reliability, special measures are required during installation and operation. It is required that the environmental and application conditions are fulfilled and that the special maintenance activities and intervals for the Foundry Prime protected robot are followed.

### Fluids in the vicinity of the robot

If fluids that can cause rust formation, for example, water etc., are used in the vicinity of the robot it is required to add rust inhibitor to the fluid or take other measures to prevent rust on unpainted joints or other unprotected surfaces of the robot.

### Activity to lubricate gearboxes cavities and gears

Run each axis on high speed at least once per hour. This activity will lubricate the gearbox cavities and gears, which reduces the risk for corrosion due to condensation in the gearboxes.

### Pressurized components

The motors, the balancing device, and the serial measurement board cavity must be pressurized on Foundry Prime robots during operation and shut down. The overpressure can be dropped when atmospheric humidity has reached the same level as the surrounding environment.

At the installation of the Foundry Prime robot a pressure sensor and pressure relief valve (not included) must be installed in the air supply system to monitor the supply of air pressure in order to secure a correct pressure. See [Pressurizing equipment on page 43](#) for equipment specifications.



#### Note

The overpressure must be kept at 0.2 - 0.3 ± 0.0 bar during 24 hours independent of Motors On/Off mode, start-up, and shut down periods.



#### WARNING

Do not to exceed the maximum pressure of 0.3 bar. If the air pressure exceeds the specified, it can lead to damage to the gearbox or brake failure in the motors which may cause the robot arms to fall down, leading to personal injury or physical damage.

*Continues on next page*



#### WARNING

If the pressurized air contains oil, it could result in a brake failure in the motors and cause the robot arms to fall down, leading to personal injury or physical damage.



#### Note

To secure the supply of air pressure, use a pressure sensor.

#### Air quality for pressurizing of robot

The air must be dry and clean, such as instrument air. The following table describes the air specifications.

Parameter	Value
Dew point	<+2° C at 6 bar
Solid particle size	<5 microns
Oil content	<1 ppm (1 mg/m <sup>3</sup> )
Air flow	>200 L/min

#### Pressurizing equipment

ABB recommends a safety valve (if not included) set at 0.4 bar, pressure sensor set at 0.2-0.3 bar or regulator set for maximum 0.3 bar to be attached on the pressure side of the air system.

Example of products:

Equipment	Description
Pressure sensor	Festo SDE1-series
Pressure regulator	Festo LRP-series

#### Connect air hose to over pressure limiter unit



#### Note

ABB recommends the air pressure to be set at maximum 0.3 bar.

*Continues on next page*

## 2 Installation and commissioning

### 2.2 Installation and operational requirements for Foundry Prime robots

*Continued*

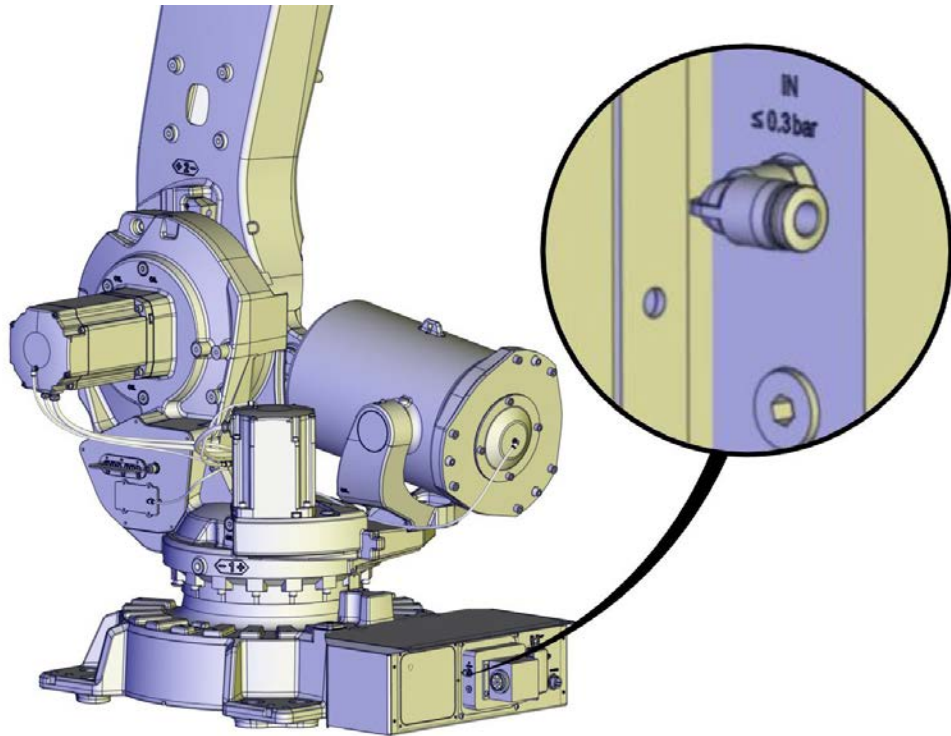

xx170000565

#### Precautionary measures



##### Note

It is strictly forbidden to expose any part of the robot to direct high pressure water jet! The sealing joints between the moving parts on the wrist must not be exposed to high pressure water.

Rebounding high pressure water jet must be avoided. ABB recommends using a tool design with integrated covers that protect the wrist from direct or indirect high pressure water jet.



##### Note

Make sure that the special Foundry Prime painting of the robot is not broken during testing, installation, or repair work. Use the touch up kit available for Foundry Prime (article number 3HAC035355-001) to repair any damage in the paint.

*Continues on next page*



#### Sensitive points IRB 4600

Illustration shows points that are particularly sensitive to water spray.

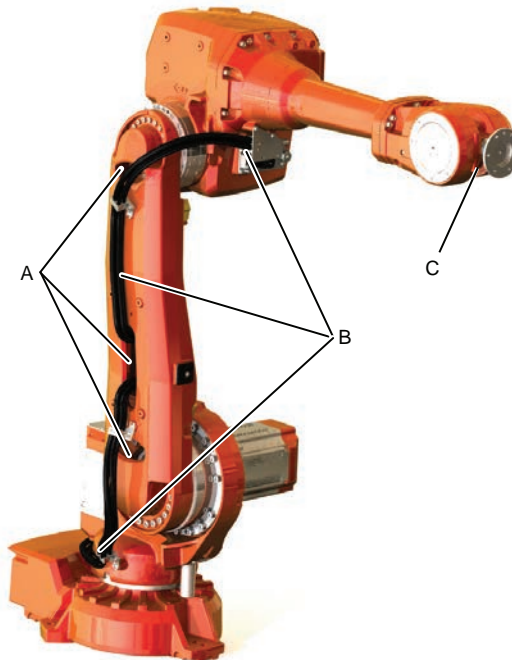

xx0800000462

A	Inside lower arm
B	Cable package
C	Wrist

*Continues on next page*

## 2 Installation and commissioning

---

### 2.2.1 Shut-down periods

### 2.2.1 Shut-down periods

---

#### Shut-down periods

During shut-down periods the cleaning cell must be ventilated out (aired out). This reduces the risk that moisture is sucked into gearboxes during cooling down. It gives the robot the possibility to dry as the rust inhibition effect normally gets reduced after some time.

Ventilate and air out the cell during and after shut-downs:

- The cell must be ventilated during shut-down until the atmospheric humidity in the cell has reached the same level as the surrounding environment.
- Will avoid that humid air is trapped into gearboxes or other cavities due to raised vacuum when cooling down.
- Will give the robot a chance to dry as most rust preventive components in washing detergents have a decaying effect, i.e. the rust preventive effect is reduced after a time. Please refer to the Product Specification of the washing detergent in question for decaying effect. Washing detergent or water without rust inhibitor can give an accelerated corrosion on some robot components.
- **The overpressure must be kept at 0.2 - 0.3 ± 0.0 bar during 24 hours independent of Motors On/Off mode, start-up and shut-down periods.**

## 2.3 Unpacking

### 2.3.1 Pre-installation procedure

#### Introduction

This section is intended for use when unpacking and installing the robot for the first time. It also contains information useful during later re-installation of the robot.

#### Prerequisites for installation personnel

Installation personnel working with an ABB product must:

- be trained by ABB and have the required knowledge of mechanical and electrical installation/maintenance/repair work
- conform to all national and local codes.

#### Checking the pre-requisites for installation

	Action
1	Make a visual inspection of the packaging and make sure that nothing is damaged.
2	Remove the packaging.
3	Check for any visible transport damage.   <b>Note</b> Stop unpacking and contact ABB if transport damages are found.
4	Clean the unit with a lint-free cloth, if necessary.
5	Make sure that the lifting accessory used (if required) is suitable to handle the weight of the robot as specified in: <a href="#">Weight, robot on page 47</a>
6	If the robot is not installed directly, it must be stored as described in: <a href="#">Storage conditions, robot on page 49</a>
7	Make sure that the expected operating environment of the robot conforms to the specifications as described in: <a href="#">Operating conditions, robot on page 50</a>
8	Before taking the robot to its installation site, make sure that the site conforms to: <ul style="list-style-type: none"> <li>• <a href="#">Loads on foundation, robot on page 48</a></li> <li>• <a href="#">Protection classes, robot on page 50</a></li> <li>• <a href="#">Requirements, foundation on page 49</a></li> </ul>
9	Before moving the robot, please observe the stability of the robot: <a href="#">Risk of tipping/stability on page 55</a>
10	When these prerequisites are met, the robot can be taken to its installation site as described in section: <a href="#">On-site installation on page 57</a>
11	Install required equipment, if any. <ul style="list-style-type: none"> <li>• <a href="#">Installation of signal lamp (option) on page 81</a></li> </ul>

#### Weight, robot

The table shows the weight of the robot.

Robot model	Weight
IRB 4600 Foundry Prime	445 kg

*Continues on next page*

## 2 Installation and commissioning

### 2.3.1 Pre-installation procedure

Continued



#### Note

The weight does not include tools and other equipment fitted on the robot.

#### Loads on foundation, robot

The illustration shows the directions of the robots stress forces.

The directions are valid for all floor mounted, suspended and inverted robots.

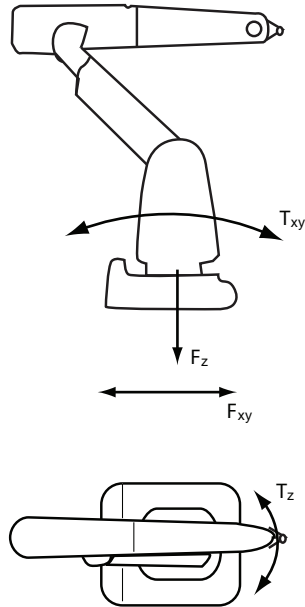

xx1100000521

$F_{xy}$	Force in any direction in the XY plane
$F_z$	Force in the Z plane
$T_{xy}$	Bending torque in any direction in the XY plane
$T_z$	Bending torque in the Z plane

The table shows the various forces and torques working on the robot during different kinds of operation.



#### Note

These forces and torques are extreme values that are rarely encountered during operation. The values also never reach their maximum at the same time!



#### WARNING

The robot installation is restricted to the mounting options given in following load table(s).

#### Floor mounted

Force	Endurance load (in operation)	Max. load (emergency stop)
Force xy	±3950 N	±7800 N

Continues on next page

Force	Endurance load (in operation)	Max. load (emergency stop)
Force z	4350 ±1700 N	4350 ±5500 N
Torque xy	±6350 Nm	±13000 Nm
Torque z	±1650 Nm	±3000 Nm

#### Suspended

Force	Endurance load (in operation)	Max. load (emergency stop)
Force xy	±3950N	±7800 N
Force z	-4350 ±1700N	-4350 ±5500 N
Torque xy	±6350 Nm	±13000 Nm
Torque z	±1650 Nm	±3000 Nm

#### Requirements, foundation

The table shows the requirements for the foundation where the weight of the installed robot is included:

Requirement	Value	Note
Flatness of foundation surface	0.5 mm	Flat foundations give better repeatability of the resolver calibration compared to original settings on delivery from ABB. The value for levelness aims at the circumstance of the anchoring points in the robot base. In order to compensate for an uneven surface, the robot can be recalibrated during installation. If resolver/encoder calibration is changed this will influence the absolute accuracy.
Maximum tilt	15°	
Minimum resonance frequency	22 Hz  <b>Note</b> It may affect the manipulator lifetime to have a lower resonance frequency than recommended.	The value is recommended for optimal performance. Due to foundation stiffness, consider robot mass including equipment. <sup>i</sup> For information about compensating for foundation flexibility, see the application manual of the controller software, section <i>Motion Process Mode</i> .

<sup>i</sup> The minimum resonance frequency given should be interpreted as the frequency of the robot mass/inertia, robot assumed stiff, when a foundation translational/torsional elasticity is added, i.e., the stiffness of the pedestal where the robot is mounted. The minimum resonance frequency should not be interpreted as the resonance frequency of the building, floor etc. For example, if the equivalent mass of the floor is very high, it will not affect robot movement, even if the frequency is well below the stated frequency. The robot should be mounted as rigid as possible to the floor.

Disturbances from other machinery will affect the robot and the tool accuracy. The robot has resonance frequencies in the region 10 – 20 Hz and disturbances in this region will be amplified, although somewhat damped by the servo control. This might be a problem, depending on the requirements from the applications. If this is a problem, the robot needs to be isolated from the environment.

#### Storage conditions, robot

The table shows the allowed storage conditions for the robot:

Parameter	Value
Minimum ambient temperature	-25° C

*Continues on next page*

## 2 Installation and commissioning

---

### 2.3.1 Pre-installation procedure

*Continued*

Parameter	Value
Maximum ambient temperature	+55° C
Maximum ambient temperature (less than 24 hrs)	+70° C
Maximum ambient humidity	95% at constant temperature (gaseous only)

---

#### Operating conditions, robot

The table shows the allowed operating conditions for the robot:

Parameter	Value
Minimum ambient temperature	+5° C
Maximum ambient temperature	+45° C
Maximum ambient humidity	100% at constant temperature (gaseous only)

---

#### Protection classes, robot

The table shows the available protection types of the robot, with the corresponding protection class.

Protection type	Protection class <sup>1</sup>
Manipulator, protection type Foundry Prime	IP 67

### 2.3.2 Surface inspection before start-up - Foundry Prime

#### Foundry Prime coating

Make sure that the special Foundry Prime painting of the robot arm surfaces is not broken or there have been any other damage during testing and installation.

Even a small collision during installation can destroy the preventive coating and the corrosion barrier is broken. Use the Touch up kit available for Foundry Prime, 3HAC035355-001, to repair damage to paint surfaces.

#### Pre-installation procedure/ Operation conditions, robot

Parameter	Value
Minimum ambient temperature	+5 °C
Maximum ambient temperature	+45 °C
Maximum ambient humidity	100% at constant temperature (gaseous only)

#### Protect attachment bolts and washers at the base

Protect the attachment bolts and washers (M24x100) at the base from physical obstructions and splashes with appropriate shield.

## 2 Installation and commissioning

### 2.3.3 Working range and type of motion

### 2.3.3 Working range and type of motion

#### Working range

The figures show the working ranges of the robot variants mounted in different ways.

The extreme positions of the robot arm are specified at the wrist center (dimensions in mm).

#### Working range, floor mounted

The illustration shows the unrestricted working range for a floor mounted robot.

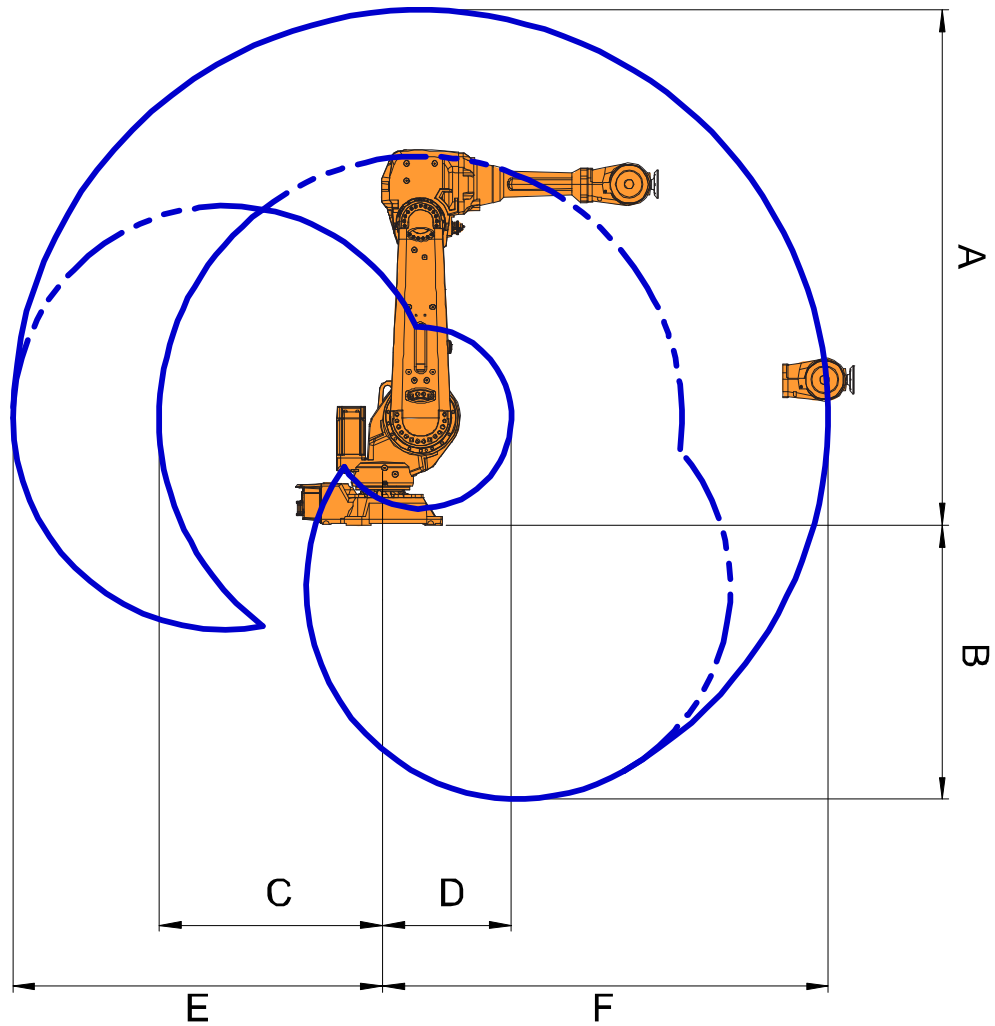

xx0800000267

Variant	Pos. A	Pos. B	Pos. C	Pos. D	Pos. E	Pos. F
IRB 4600 - 60/2.05	2371 mm	1260 mm	1028 mm	593 mm	1701 mm	2051 mm

*Continues on next page*



#### Working range, suspended mounted

The illustration shows the unrestricted working range for a suspended mounted robot.

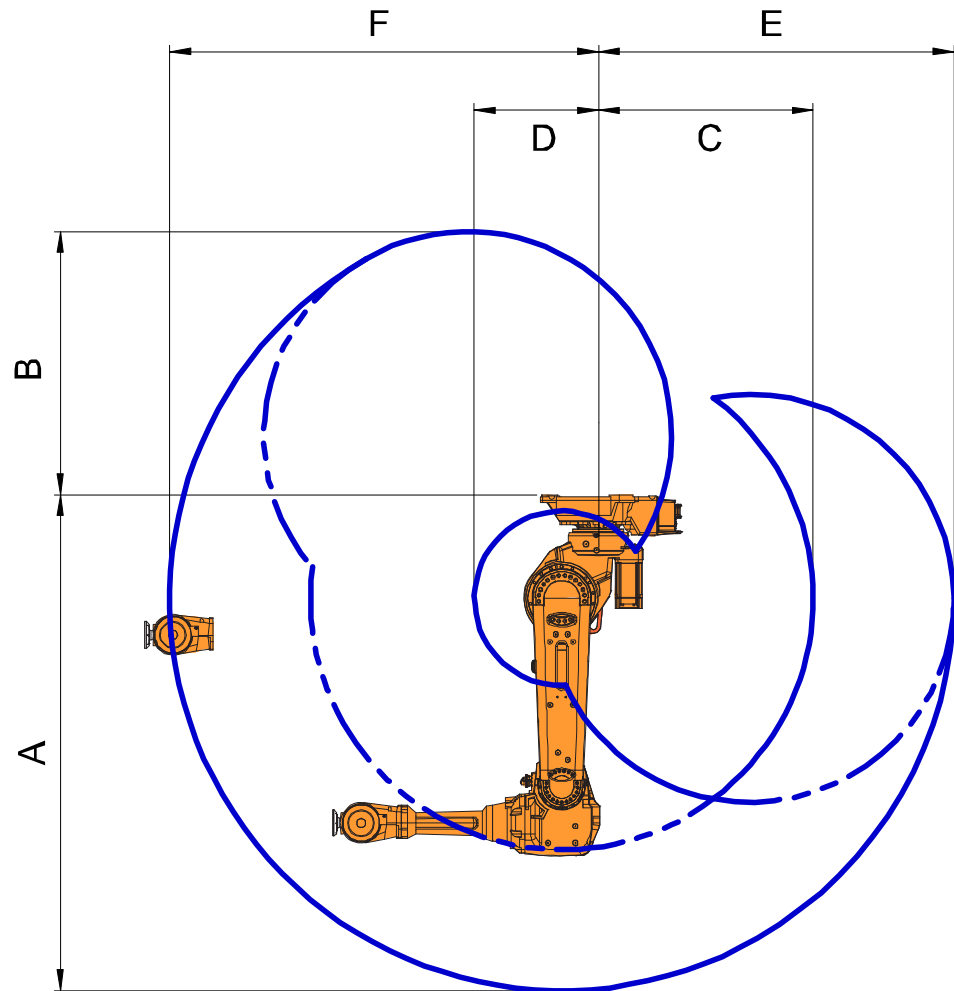

xx0900000055

Variant	Pos. A	Pos. B	Pos. C	Pos. D	Pos. E	Pos. F
IRB 4600 - 60/2.05	2371 mm	1260 mm	1028 mm	593 mm	1701 mm	2051 mm

*Continues on next page*

## 2 Installation and commissioning

### 2.3.3 Working range and type of motion

Continued

#### Turning radius

The turning radius of the robot that is floor or suspended mounted is shown in the figure.

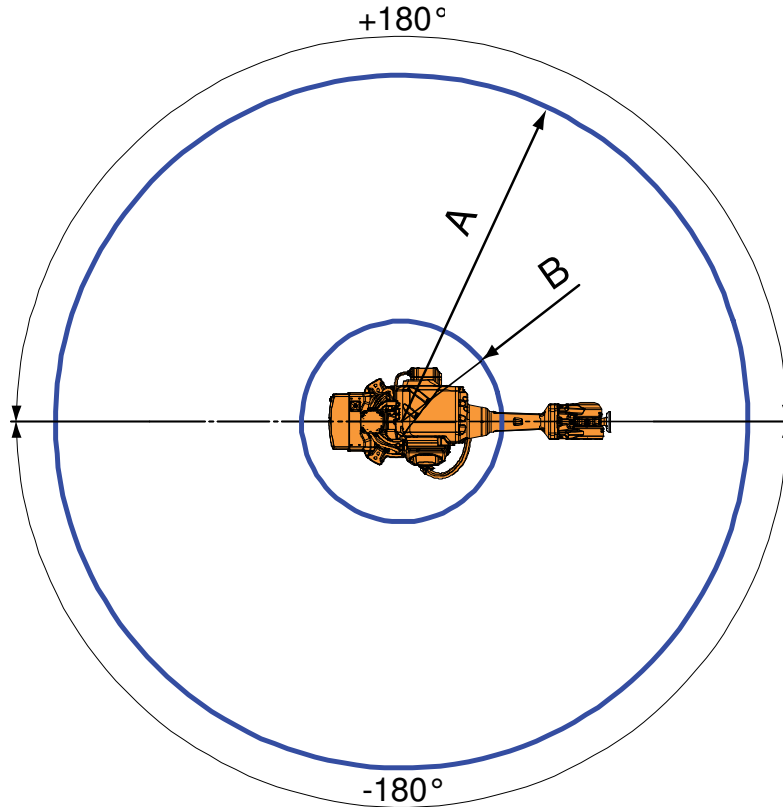

xx080000268

Variant	Pos. A	Pos. B
IRB 4600 - 60/2.05	R2051	R593

#### Robot motion, IRB 4600-60/2.05

The table specifies the types and ranges of motion in every axes.

Location of motion	Type of motion	Range of movement
Axis 1	Rotation motion	$\pm 180^\circ$
Axis 2	Arm motion	$+150^\circ / -90^\circ$
Axis 3	Arm motion	$+75^\circ / -180^\circ$
Axis 4	Wrist motion	$\pm 400^\circ$
Axis 5	Bend motion	$+120^\circ / -125^\circ$
Axis 6	Turn motion	$\pm 400^\circ$

#### 2.3.4 Risk of tipping/stability

##### Risk of tipping

Do not change the robot position before securing it to the foundation.

The shipping position is the most stable position.

##### Shipping and transportation position

This figure shows the robot in its shipping position and transportation position.

The position of the calibration mark (A) in the figure is approximate and is used as aiming aid.

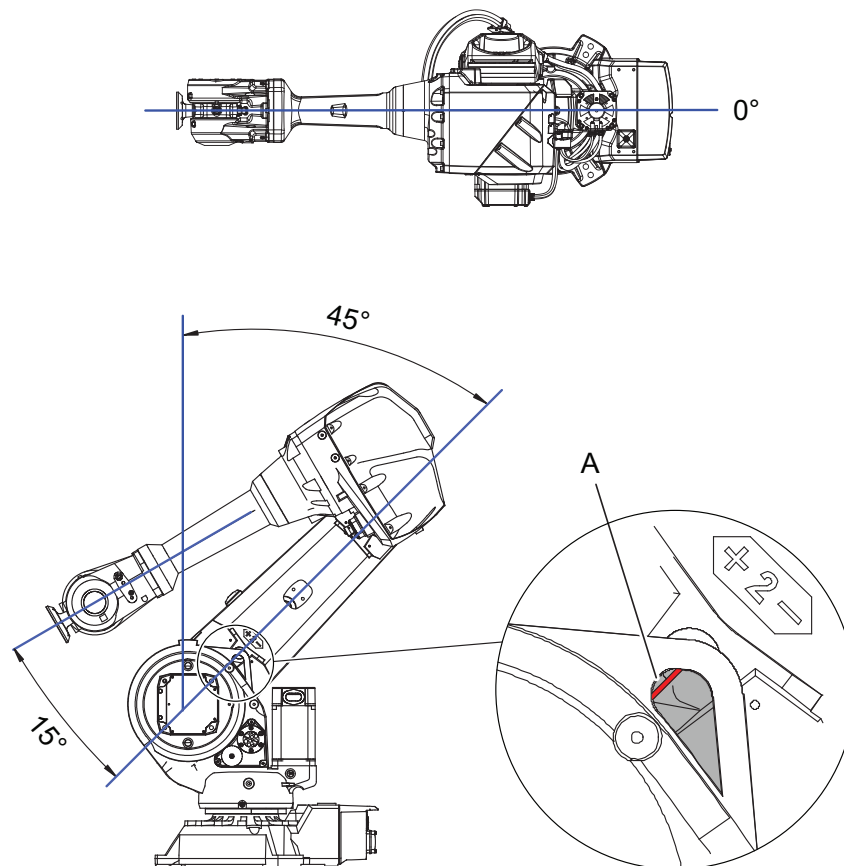

xx080000263



#### WARNING

The robot will be mechanically unstable if not properly secured to the foundation.

## 2 Installation and commissioning

---

### 2.3.5 The unit is sensitive to ESD

### 2.3.5 The unit is sensitive to ESD

---

#### Description

ESD (electrostatic discharge) is the transfer of electrical static charge between two bodies at different potentials, either through direct contact or through an induced electrical field. When handling parts or their containers, personnel not grounded may potentially transfer high static charges. This discharge may destroy sensitive electronics.

#### Safe handling

Use one of the following alternatives:

- Use a wrist strap.

Wrist straps must be tested frequently to ensure that they are not damaged and are operating correctly.

- Use an ESD protective floor mat.

The mat must be grounded through a current-limiting resistor.

- Use a dissipative table mat.

The mat should provide a controlled discharge of static voltages and must be grounded.

## 2.4 On-site installation

### 2.4.1 Lifting robot with roundslings

#### Introduction

When lifting the robot use roundslings and an overhead crane.

How to lift *suspended mounted robot* is described in the lifting instruction delivered with the turning tool art. no. 3HAC034766-001. See [Lifting and turning a suspended mounted robot on page 60](#).

#### Required equipment

Equipment	Note
Overhead crane	Lifting capacity 1 000 kg (Max load at 90°)
Roundslings (2 pcs)	<ul style="list-style-type: none"> <li>Lifting capacity/roundsling: 1 000 kg</li> <li>Length: 2 m</li> </ul>

#### Lifting

Attach the roundslings as shown in the figure.

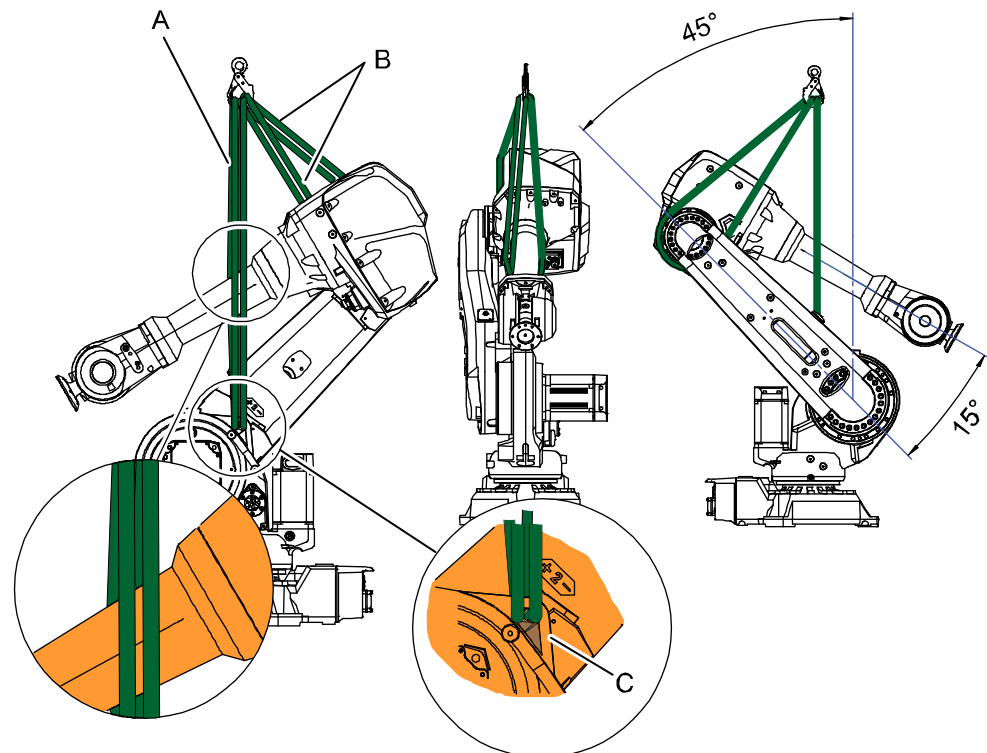

xx0800000262

A	Roundsling put folded in U-shape through the lifting lug
B	Roundsling put folded in U-shape around gearbox axis 3
C	Lifting lug

*Continues on next page*





## 2 Installation and commissioning

### 2.4.1 Lifting robot with roundslings

Continued

#### Lifting instructions

Use this procedure to lift the robot in a safe way.

	Action	Note
1	 <b>CAUTION</b> The IRB 4600 Foundry Prime robot weighs 445 kg. All lifting accessories used must be sized accordingly!	
2	 <b>CAUTION</b> Attempting to lift the robot in any other position than that recommended may result in the robot tipping over and causing severe damage or injury!	
3	 <b>WARNING</b> Personnel must not, under any circumstances, be present under the suspended load!	
4	Move the robot to its most stable position.	Detailed in section: <ul style="list-style-type: none"><li>• <a href="#">Risk of tipping/stability on page 55</a></li></ul>
5	 <b>DANGER</b> Turn off all: <ul style="list-style-type: none"><li>• electric power supply</li><li>• hydraulic pressure supply</li></ul> to the robot, before entering the robot working area.	
6	Attach <i>roundsling A</i> to the lifting lug on the frame, and put folded in a U-shape on either side of the upper arm.	See the figure in: <ul style="list-style-type: none"><li>• <a href="#">Lifting on page 57</a></li></ul>
7	Attach <i>roundsling B</i> at axis 3 gearbox by running it folded in a U-shape around the gearbox.	See the figure in: <ul style="list-style-type: none"><li>• <a href="#">Lifting on page 57</a></li></ul>
8	Make sure the roundslings do not rub against any sharp edges.	

Continues on next page

## 2 Installation and commissioning

### 2.4.1 Lifting robot with roundslings

*Continued*

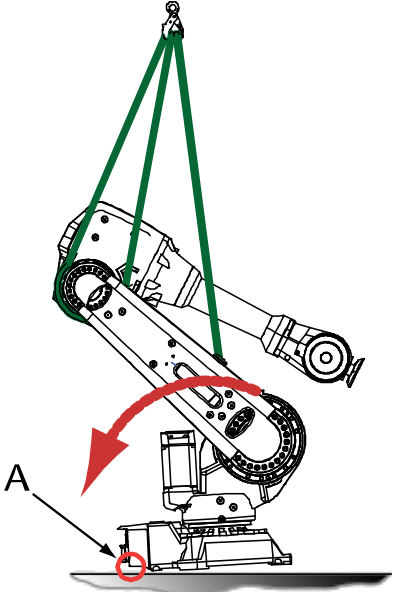
	Action	Note
9	<p>When the robot is lifted the roundslings will adjust themselves.</p> <p> <b>CAUTION</b></p> <p>When lifting, the robot will tilt slightly backwards! Be careful not to damage the <i>connection box</i> at the base of the robot!</p>	 <p>xx0800000291</p> <ul style="list-style-type: none"><li>• A: Area where the connection box can be damaged while lifting.</li></ul>
10	Lift the robot with an overhead crane.	<p>Lifting capacity:</p> <ul style="list-style-type: none"><li>• See <a href="#">Required equipment on page 57</a></li></ul>

## 2 Installation and commissioning

---

### 2.4.2 Lifting and turning a suspended mounted robot

### 2.4.2 Lifting and turning a suspended mounted robot

---

#### Introduction

How to lift and turn the robot to a suspended position using the turning accessory is described in the lifting instruction delivered with the turning accessory. Article numbers for the accessory and the instruction is specified in [Special tools on page 399](#). Any additional equipment required is specified in the instruction for the lifting accessory. Contact ABB for more information.

---

#### Illustration

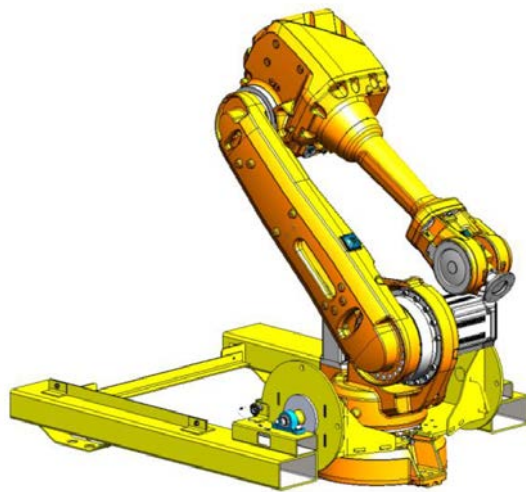

xx1500002116



### 2.4.3 Setting the system parameters for a suspended or tilted robot

#### General

The robot is configured for mounting parallel to the floor, without tilting, on delivery. The method for mounting the robot in a suspended (upside down) or tilted position is basically the same as for floor mounting, but the system parameters that describe the mounting angle (how the robot is oriented relative to the gravity) must be re-defined.



#### Note

With suspended installation, make sure that the gantry or corresponding structure is rigid enough to prevent unacceptable vibrations and deflections, so that optimum performance can be achieved.



#### Note

The allowed mounting positions are described in the product specification for the robot. The requirements on the foundation are described in [Requirements, foundation on page 49](#).

#### System parameters



#### Note

The mounting angle must be configured correctly in the system parameters so that the robot system can control the movements in the best possible way. An incorrect definition of the mounting angle will result in:

- Overloading the mechanical structure.
- Lower path performance and path accuracy.
- Some functions will not work properly, for example *Load Identification* and *Collision detection*.

#### Gravity Beta

If the robot is mounted upside down or tilted (rotated around the y-axis), then the robot base frame and the system parameter *Gravity Beta* must be redefined. *Gravity Beta* should then be  $\pi$  (+3.141593) if the robot is mounted upside down (suspended).

The *Gravity Beta* is a positive rotation direction around the y-axis in the base coordinate system. The value is set in radians.

*Continues on next page*

## 2 Installation and commissioning

---

### 2.4.3 Setting the system parameters for a suspended or tilted robot

*Continued*

#### Gravity Alpha

The *Gravity Alpha* is a positive rotation direction around the x-axis in the base coordinate system. The value is set in radians.



#### Note

The system parameter *Gravity Alpha* is not supported for all robot types. It is not supported for IRB 140, IRB 1410, IRB 1600ID, IRB 2400, IRB 4400, IRB 6400R, IRB 6400 (except for IRB 6400 200/2.5 and IRB 6400 200/2.8), IRB 6600, IRB 6650, IRB 6650S and IRB 7600 (except for IRB 7600 325/3.1).

If the robot does not support *Gravity Alpha*, then use *Gravity Beta* along with the recalibration of axis 1 to define the rotation of the robot around the x-axis.



#### Note

The parameter is supported for all robots on track when the system parameter *7 axes high performance motion* is set, see *Technical reference manual - System parameters*.

#### Gamma Rotation

*Gamma Rotation* defines the orientation of the robot foot on the travel carriage (track motion).

---

#### Mounting angles and values

The parameter *Gravity Beta* (or *Gravity Alpha*) specifies the mounting angle of the robot in radians. It is calculated in the following way.

Gravity Beta =  $A^\circ \times 3.141593/180 = B$  radians, where **A** is the mounting angle in degrees and **B** is the mounting angle in radians.

Example of position	Mounting angle (A°)	Gravity Beta
Floor mounted	0°	0.000000 (Default)
Suspended mounting	180°	3.141593

*Continues on next page*

Examples of mounting angles tilted around the Y axis (*Gravity Beta*)

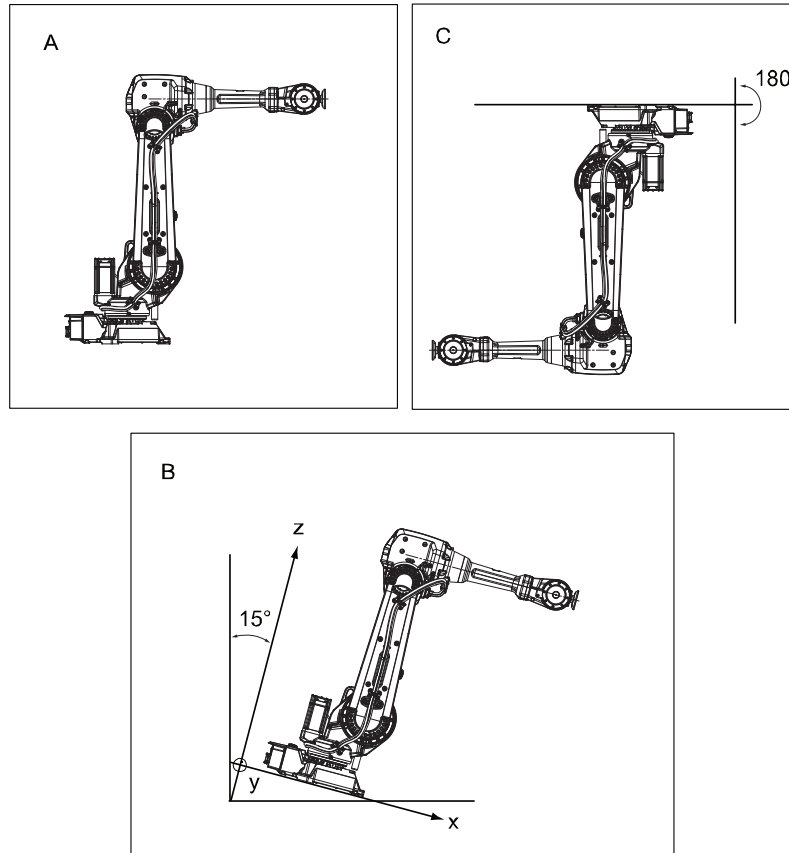

xx170000267

A	Floor mounted
B	Tilted mounting, mounting angle 15°.
C	Suspended mounting, mounting angle 180°.

*Continues on next page*

## 2 Installation and commissioning

### 2.4.3 Setting the system parameters for a suspended or tilted robot

*Continued*

Examples of mounting angles tilted around the X axis (*Gravity Alpha*)

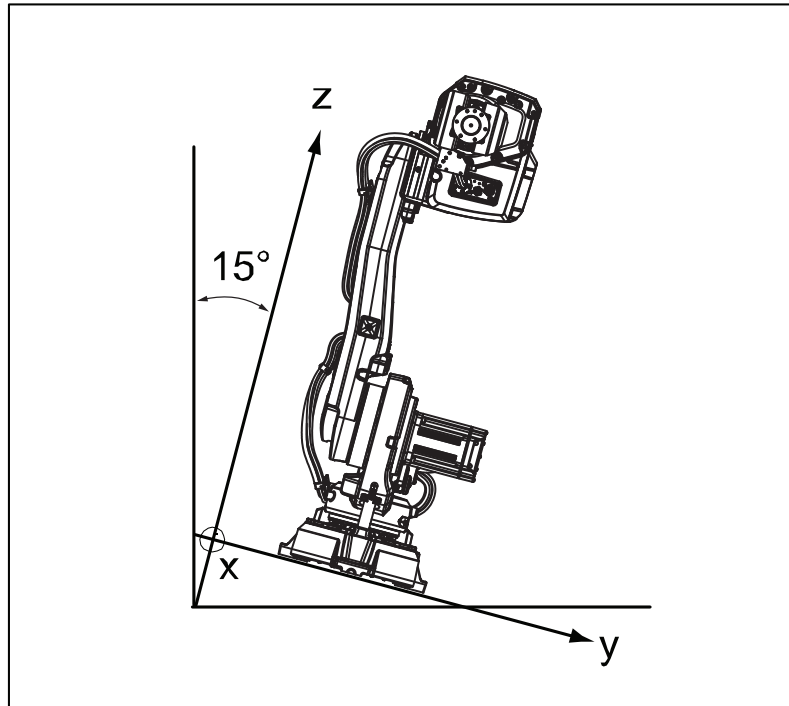

xx170000268

-	Tilted mounting, mounting angle 15°.
---	--------------------------------------



#### Note

For suspended robots (180°), it is recommended to use *Gravity Beta* instead of *Gravity Alpha*.

#### Defining the parameter in RobotWare

The value of the system parameters that define the mounting angle must be redefined when changing the mounting angle of the robot. The parameters belong to the type *Robot*, in the topic *Motion*.

How to calculate a new value is detailed in [Mounting angles and values on page 62](#).

The system parameters are described in *Technical reference manual - System parameters*.

The system parameters are configured in RobotStudio or on the FlexPendant.

#### 2.4.4 Manually releasing the brakes

##### General

The section below describes how to release the holding brakes of each axis' motor.

This can be done in one of three ways:

- using the push-button when the robot is connected to the controller.
- using the push-button on the robot with an external power supply.
- using an external voltage supply directly on the respective brake.



#### DANGER

When releasing the holding brakes with push-buttons, the robot must be properly attached!



#### DANGER

When releasing the holding brakes, the robot axes may move very quickly and sometimes in unexpected ways!

Make sure no personnel is near or beneath the robot arm!

##### Using the push-button when the robot is connected to the controller

This procedure details how to release the holding brakes with push-buttons, when the robot is connected to the controller.

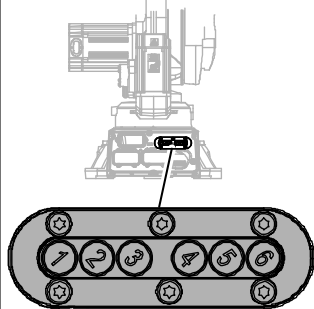
	Action	Note
1	The internal brake release unit is located at the base of the robot.	 <p>xx0800000272</p>
2	The brake release unit is equipped with six buttons for controlling the axes brakes. The buttons are numbered according to the numbers of the axes.	
3	Release the holding brake on a particular axis by pressing the corresponding button on the push-button unit and keeping it depressed.	
4	The brake will function again as soon as the button is released.	

*Continues on next page*



## 2 Installation and commissioning

### 2.4.4 Manually releasing the brakes

Continued

#### Using the push-button on the robot with an external power supply

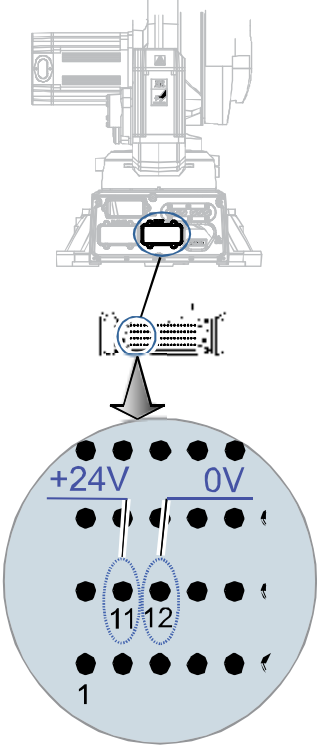

This procedure details how to release the holding brakes with the push-buttons, when the robot is **not** connected to the controller.

	Action	Note
1	<p>Connect an external 24VDC power supply to the connector R1.MP on the robot base.</p> <p> <b>Note</b></p> <p>Be careful not to interchange the 24V and 0V pins! If they are mixed up, damage can be caused to the brake release unit and the system board!</p> <p> <b>WARNING</b></p> <p>Incorrect connections can cause all brakes to be released simultaneously!</p>	 <p>xx080000269</p> <p>Connect to connector R1.MP:</p> <ul style="list-style-type: none"> <li>• 0V to pin 12</li> <li>• +24V to pin 11</li> </ul>
2	<p>Release the holding brake on a particular axis by pressing the corresponding button on the push-button unit and keeping it depressed.</p>	<p>The brake release unit is equipped with six buttons for controlling the axes brakes. The buttons are numbered according to the numbers of the axes. See the previous figure.</p>
3	<p>The brake will function again as soon as the button is released.</p>	

Continues on next page

#### Using an external voltage supply directly on the respective brake

This procedure details how to release the holding brake of a specific axis by supplying external voltage directly on the brake.

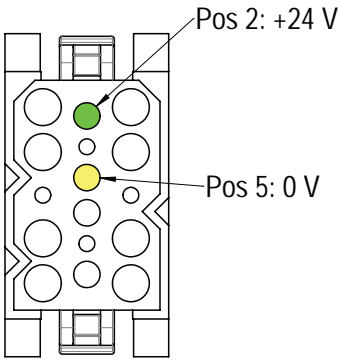
	Action	Note
1	<p>Every axis has a holding brake built into the axis motor. This holding brake may be released by connecting 24VDC power supply directly to one of the connectors in the motor.</p> <p> <b>DANGER</b></p> <p>When power is connected directly to the brake cable, the brake will be released immediately when the power is switched on. This may cause some unexpected robot movements!</p>	<p>Make the connection to the current motor according to the Circuit Diagram. See chapter <a href="#">Circuit diagram on page 405</a>.</p>
2	<p>Connect an external 24 VDC power supply to the motor, according to the figures.</p> <p> <b>Note</b></p> <p>Be careful not to interchange the 24V and 0V pins! If they are mixed up, damage can be caused to the intergrated quenching circuits.</p> <p> <b>WARNING</b></p> <p><b>Incorrect connections can cause all brakes to be released simultaneously!</b></p>	<p>Axes 1, 2 and 3:</p>  <p>xx1400001984</p>

## 2 Installation and commissioning

### 2.4.5 Orienting and securing the robot

### 2.4.5 Orienting and securing the robot

#### Introduction

This section describes how to orient and secure the robot to the foundation or base plate in order to run the robot safely. The requirements made on the foundation are shown in sections [Loads on foundation, robot on page 48](#) and [Requirements, foundation on page 49](#).

#### Hole configuration, base

The illustration shows the hole configuration used when securing the robot.

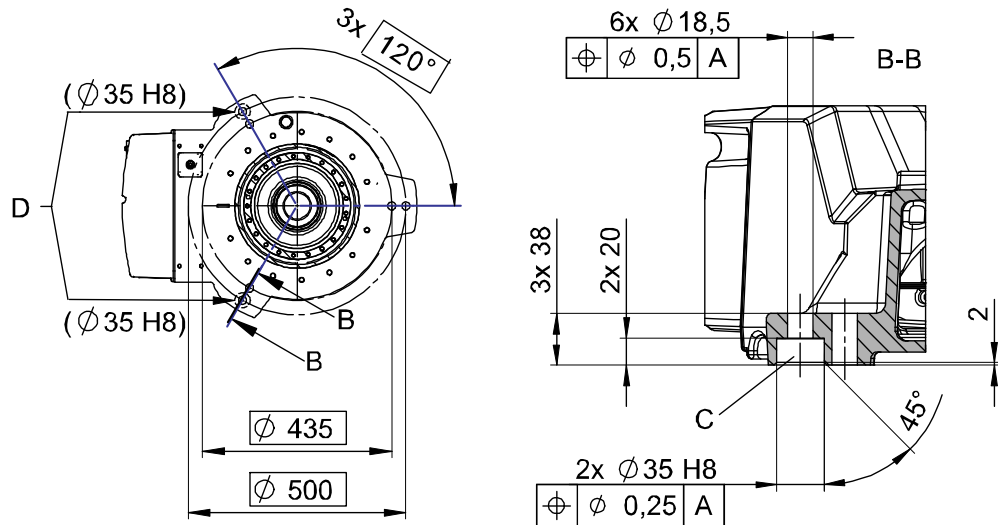

xx080000271

C	Hole for guide bushing
D	Rear bolt holes

*Continues on next page*



#### Dimension, mounting surface and guide bushing

The figure shows the dimension of the mounting surface and guide bushings.

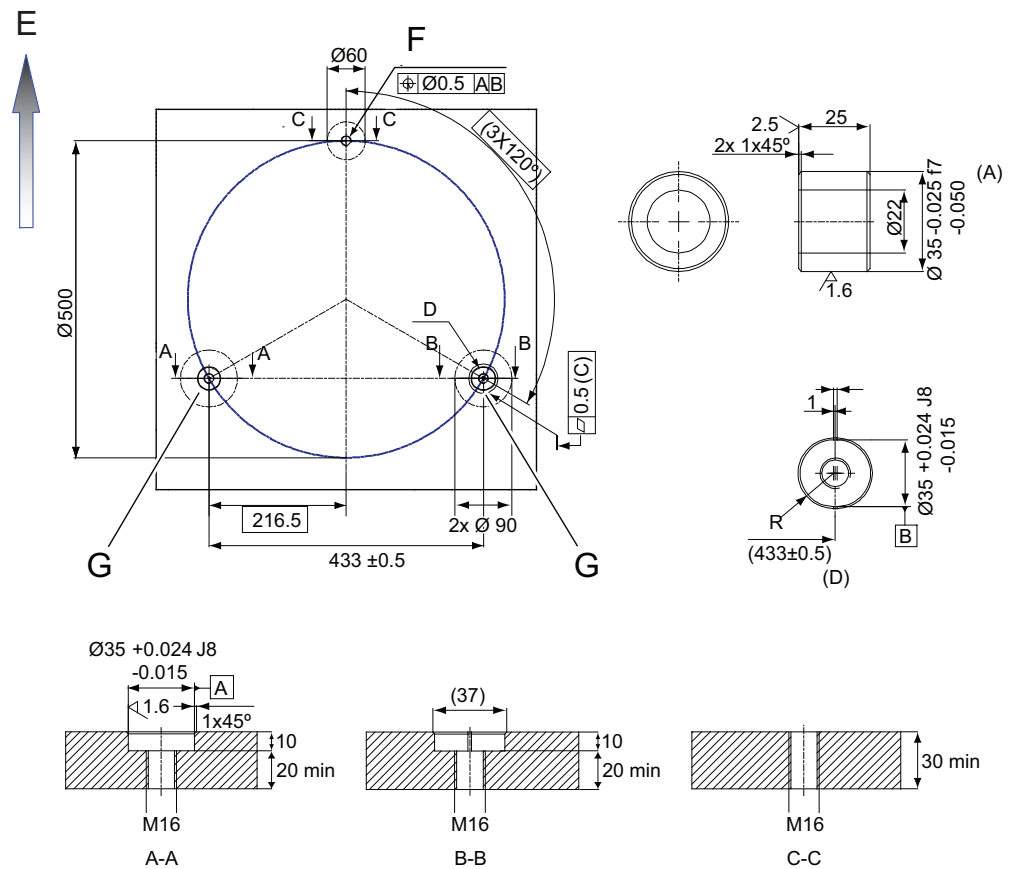

xx1700001492

(C)	3x common zone
E	Position of the front of the robot
F	M16 (3 pcs)
G	Guide bushings (2 pcs)

#### Specification, attachment screws

The table specifies the type of securing screws and washers to be used to secure the robot to the foundation or base plate.

Securing parts/Facts	Dimension	Note
Securing screws, oiled	M16 x 60 (installation directly on foundation) M16 x 70/80 (installation on foundation or base plate, using guide bushings) Quality 8.8	6 pcs 200 Nm
Washers	17 x 30 x 3	6 pcs

*Continues on next page*

## 2 Installation and commissioning

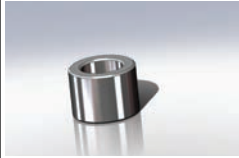
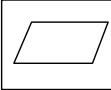

### 2.4.5 Orienting and securing the robot

Continued

Securing parts/Facts	Dimension	Note
Guide bushings		<p>Article number: 21510024-169, 2 pcs.</p> <p>Added to the rear bolt holes, to allow the same robot to be re-mounted without program adjustments.</p>  <p>xx1200000885</p>
Level surface requirements	 <p>0.5</p> <p>xx0300000251</p>	

### Orienting and securing the robot

Use this procedure to orient and secure the robot.

	Action	Note
1	Make sure the installation site for the robot conforms to the specifications in section <a href="#">Pre-installation procedure on page 47</a> .	
2	Prepare the installation site with attachment holes.	<p>Hole configuration of the base is shown in the figure in:</p> <ul style="list-style-type: none"> <li><a href="#">Hole configuration, base on page 68</a></li> </ul>
3	 <b>CAUTION</b> <p>The IRB 4600 Foundry Prime robot weighs 445 kg.            All lifting accessories used must be sized accordingly!</p>	
4	 <b>CAUTION</b> <p>When the robot is put down after being lifted or transported, there is a risk of it tipping, if not properly secured.</p>	
5	Lift the robot to its installation site.	<p>How to lift the robot is described in section:</p> <ul style="list-style-type: none"> <li><a href="#">Lifting robot with roundslings on page 57</a></li> </ul>
6	Fit two <i>guide bushings</i> to the <i>rear bolts</i> in the base.	
7	Guide the robot gently, using the attachment screws while lowering it into its mounting position.	Make sure the robot base is correctly fitted onto the guide sleeves.

Continues on next page

	Action	Note
8	Fit the <i>securing screws</i> and <i>washers</i> in the attachment holes of the base.	
9	Tighten the bolts in a criss-cross pattern to ensure that the base is not distorted.	

#### Securing robot on a mounting plate

When bolting a mounting plate or frame to a concrete floor, follow the general instructions for expansion-shell bolts.

Screw joints must be able to withstand the stress loads defined in section [Loads on foundation, robot on page 48](#).

## 2 Installation and commissioning

---

### 2.4.6 Fitting equipment on robot

### 2.4.6 Fitting equipment on robot

---

#### Introduction

The robot features mounting holes for additional equipment.

Access to any of the following mounting holes may be obstructed by any additional cabling, equipment, etc., fitted by the robot user. Make sure the required mounting holes are accessible when planning the robot cell.



#### Note

All equipment and cables used on the robot, must be designed and fitted not to damage the robot and/or its parts.



#### Note

Never drill a hole in the robot without first consulting ABB!

*Continues on next page*

#### Fitting equipment on robot - Load areas

The shaded area indicates the permitted positions (center of gravity) for any extra equipment fitted in the holes intended for this purpose.

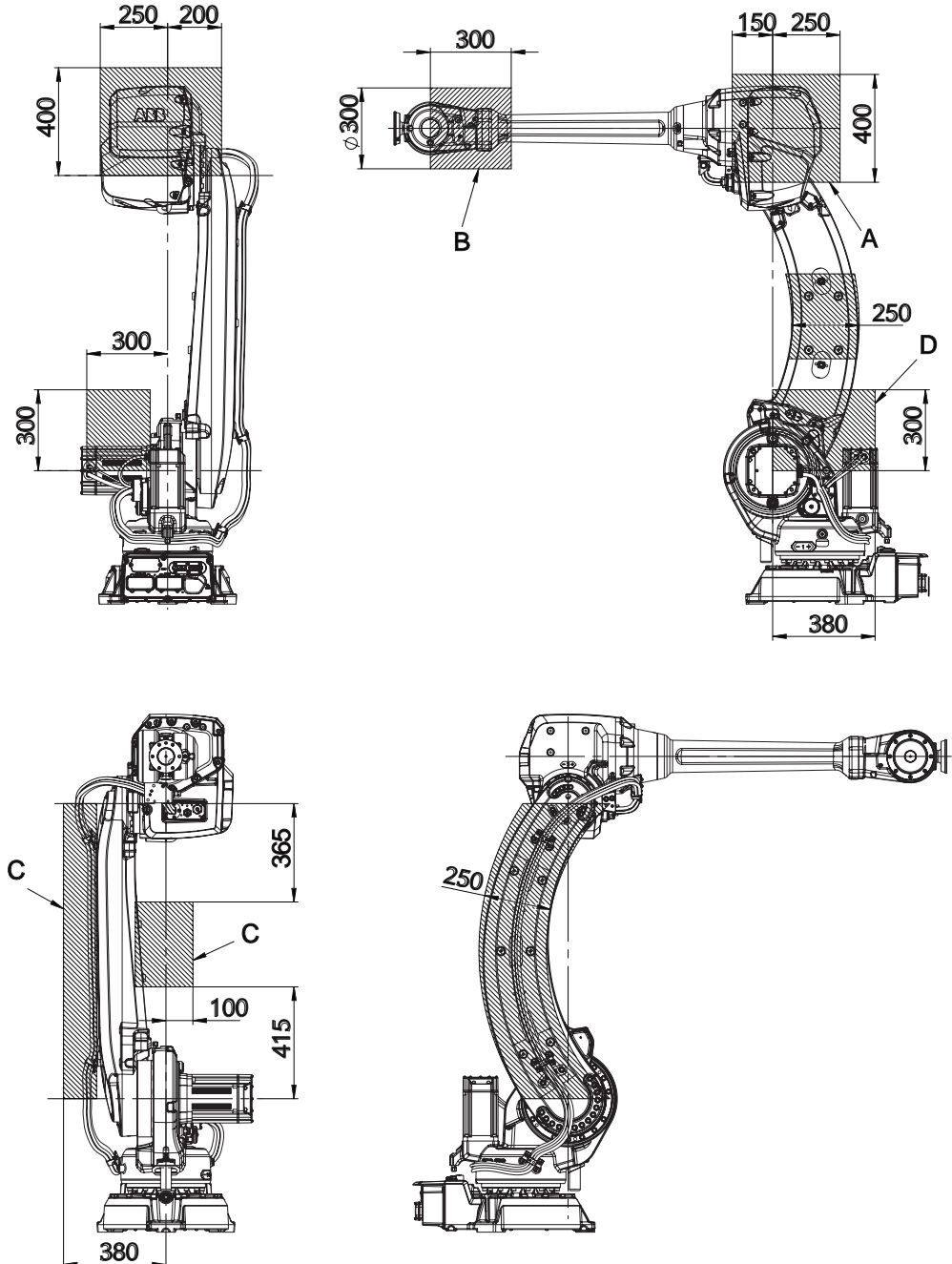

xx220000805

Variant	Max load A	Max load B	Max load C	Max load A+C	Max load D
IRB 4600CLA-40/2.55	10 kg	5 kg <sup>i</sup>	10 kg <sup>ii</sup>	10 kg	35 kg

<sup>i</sup> Payload + B = Max 40 kg

<sup>ii</sup> Total for load area C

*Continues on next page*

## 2 Installation and commissioning

### 2.4.6 Fitting equipment on robot

Continued



#### Note

Maximum loads must never be exceeded!

#### Fitting equipment on base and frame

The illustrations show the fitting holes available for fitting extra equipment on the base and frame of the robot.

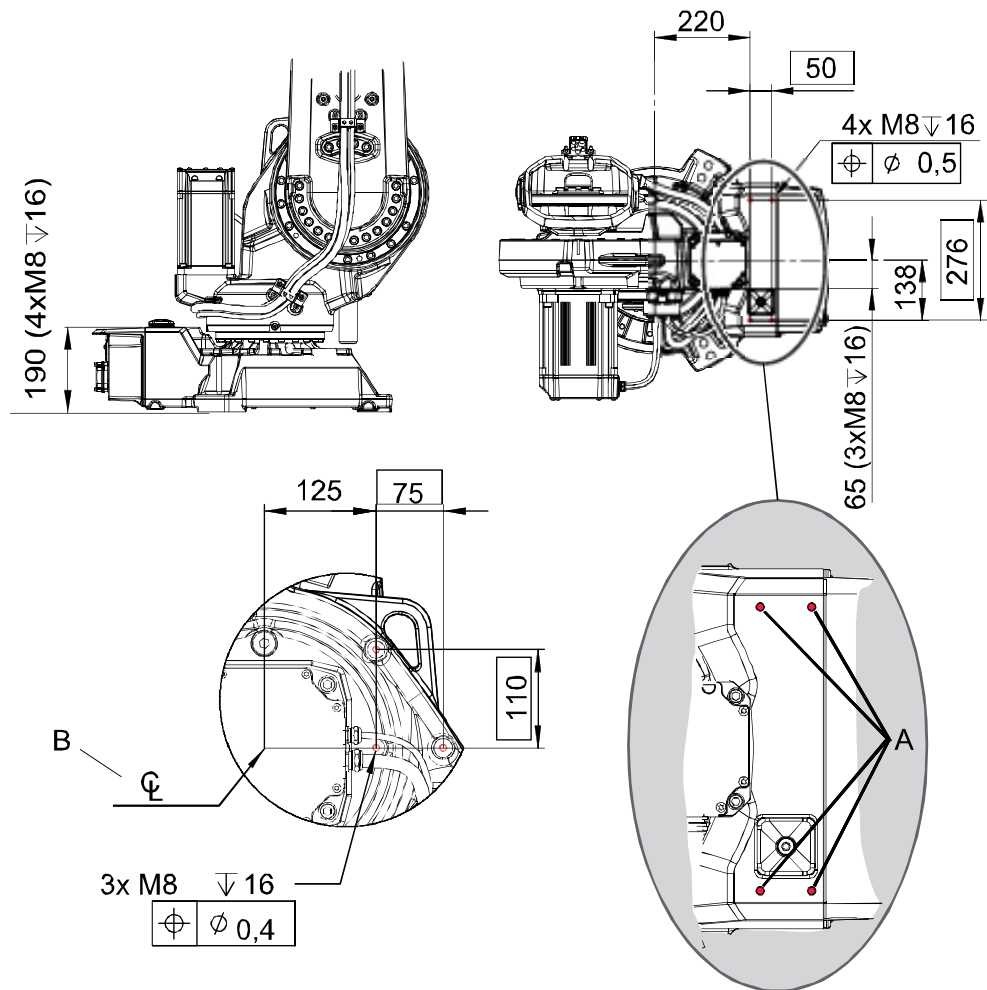

xx0800000276

A	Attachment holes on base
B	Center axis 2

Continues on next page

#### Fitting equipment on lower and upper arm

The illustrations show the fitting holes available for fitting extra equipment on the lower and upper arm of the robot.

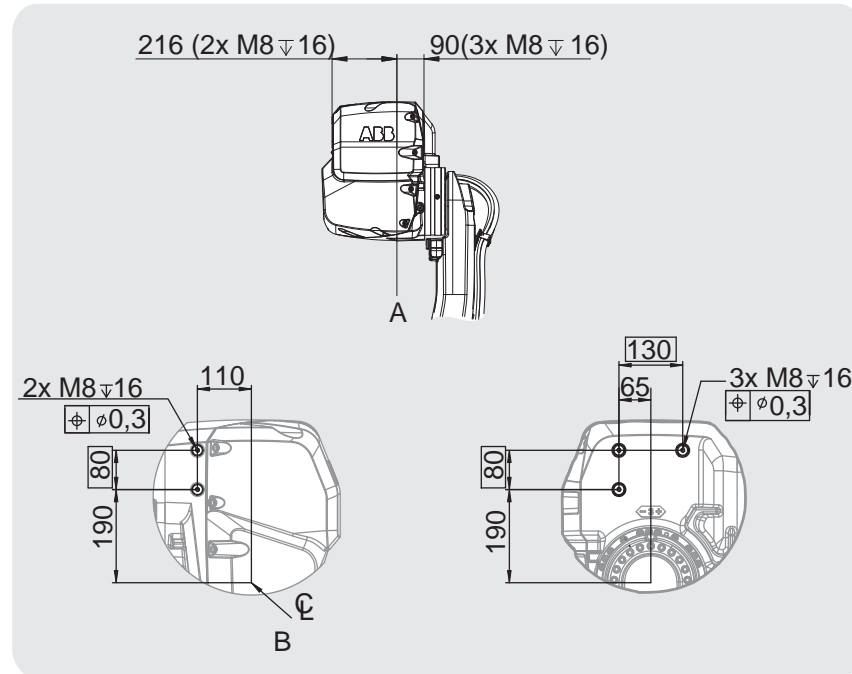

xx080000280

A	Center axis 4
B	Center axis 3

*Continues on next page*

## 2 Installation and commissioning

### 2.4.6 Fitting equipment on robot

Continued

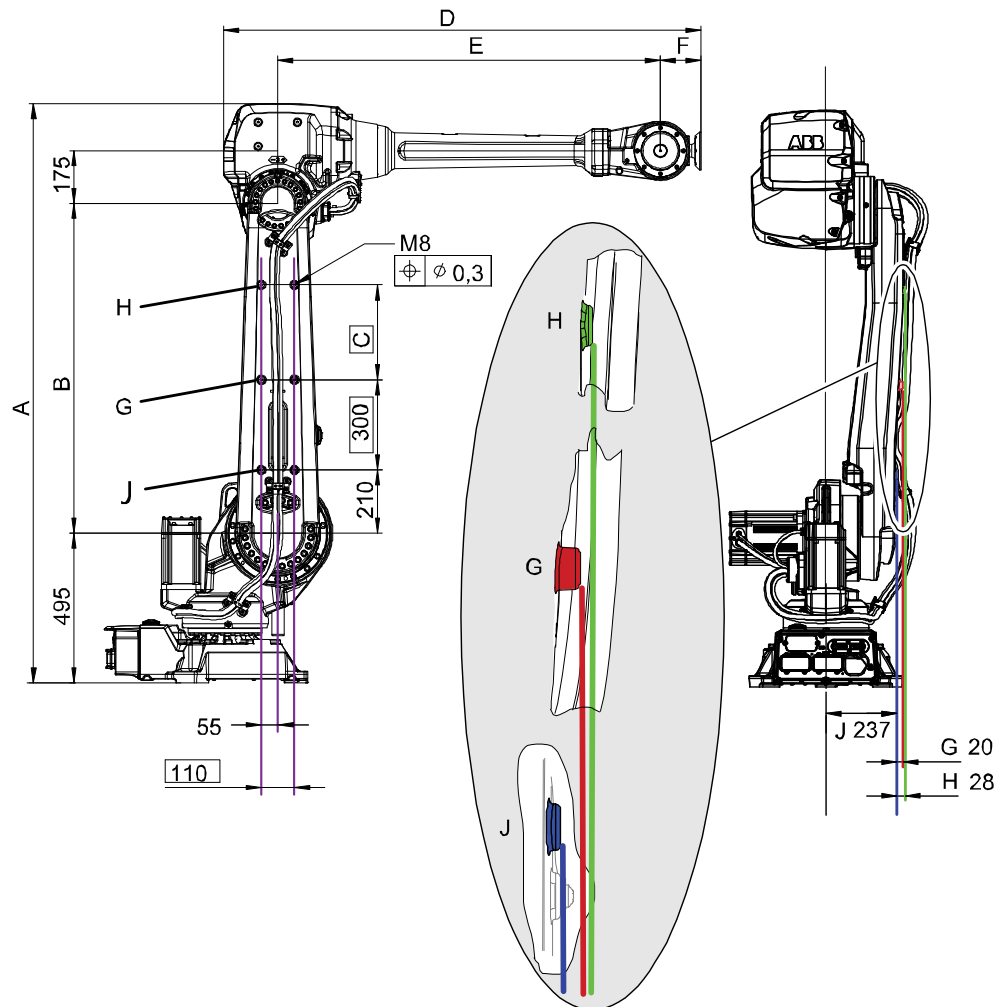

xx0800000279

Variant	A (mm)	B (mm)	C (mm)	D (mm)	E (mm)	F (mm)	G (mm)	H (mm)	J (mm)
60/2.05	1727	900	See note <sup>i</sup>	1276	960	135	20	See note <sup>i</sup>	237

<sup>i</sup> Position H and measurement C is only applicable to IRB 4600 - 40/2.55 and IRB 4600 - 20/2.50.  
Position H and measurement C is only applicable to IRB 4600 - 40/2.55 and IRB 4600 - 20/2.50.

Variant	Attachment screws
60/2.05	4x M8, through



#### Note

On delivery, all of the extra fitting holes are covered with coated set screws. Remove these to fit extra equipment. Seal with Mercasol.



#### Note

If extra equipment is removed, cover up equipment holes with coated set screws. Seal with Mercasol.

Continues on next page



#### Fitting equipment on wrist and mounting flange

Extra equipment on wrist, robot versions IRB 4600 -60/2.05

The illustration shows the fitting holes available for fitting extra equipment on the wrist of the robot.

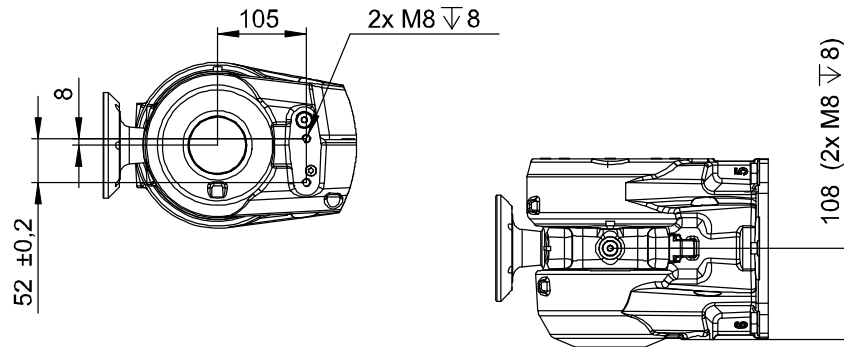

xx080000277



#### Note

Do not remove screws indicated in the illustration below!

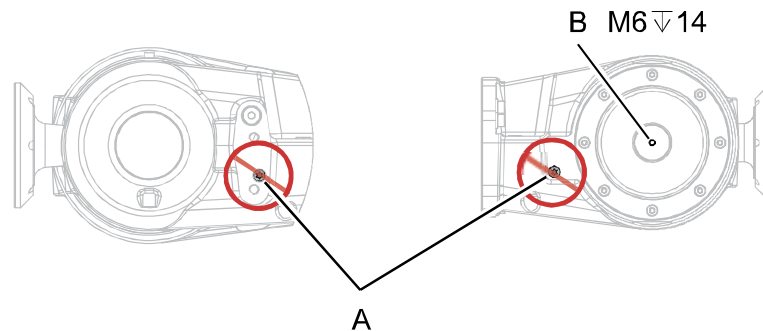

xx080000281

A	Screws not to be removed! Do not use these holes for fitting equipment on the wrist!
B	Screw hole intended for swivel fitting.

*Continues on next page*



#### 2.4.7 Surface inspection before start-up - Foundry Prime

##### Foundry Prime coating

Make sure that the special Foundry Prime painting of the robot arm surfaces is not broken or there have been any other damage during testing and installation.

Even a small collision during installation can destroy the preventive coating and the corrosion barrier is broken. Use the Touch up kit available for Foundry Prime, 3HAC035355-001, to repair damage to paint surfaces.

##### Pre-installation procedure/ Operation conditions, robot

Parameter	Value
Minimum ambient temperature	+5 °C
Maximum ambient temperature	+45 °C
Maximum ambient humidity	100% at constant temperature (gaseous only)

##### Protect attachment bolts and washers at the base

Protect the attachment bolts and washers (M24x100) at the base from physical obstructions and splashes with appropriate shield.

## 2 Installation and commissioning

---

### 2.4.8 Loads fitted to the robot, stopping time and braking distances

### 2.4.8 Loads fitted to the robot, stopping time and braking distances

---

#### General

Any loads mounted on the robot must be defined correctly and carefully (with regard to the position of center of gravity and mass moments of inertia) in order to avoid jolting movements and overloading motors, gears and structure.



#### CAUTION

Incorrectly defined loads may result in operational stops or major damage to the robot.

#### References

Load diagrams, permitted extra loads (equipment) and their positions are specified in the product specification. The loads must be defined in the software.

- *Operating manual - IRC5 with FlexPendant*

#### Stopping time and braking distances

The performance of the motor brake depends on if there are any loads attached to the robot. For more information, see product specification for the robot.

#### 2.4.9 Installation of signal lamp (option)

---

##### Signal lamp

See the assembly instruction delivered with the signal lamp.

## 2 Installation and commissioning

---

### 2.5.1 Axes with restricted working range

## 2.5 Restricting the working range

### 2.5.1 Axes with restricted working range

---

#### General

When installing the robot, make sure that it can move freely within its entire working space. If there is a risk that it may collide with other objects, its working space should be limited.

The working range of the following axes may be restricted:

- Axis 1, hardware (mechanical stop) and software
- Axis 2, software
- Axis 3, software.

This section describes how to install hardware that restricts the working range.



#### Note

Adjustments must also be made in the robot configuration software (system parameters). References to relevant manuals are included in the installation procedures.



#### WARNING

Remove the mechanical stop bracket if the robots full working range is from one mechanical stop to another mechanical stop. Otherwise the mechanical stop pin will be worn out.

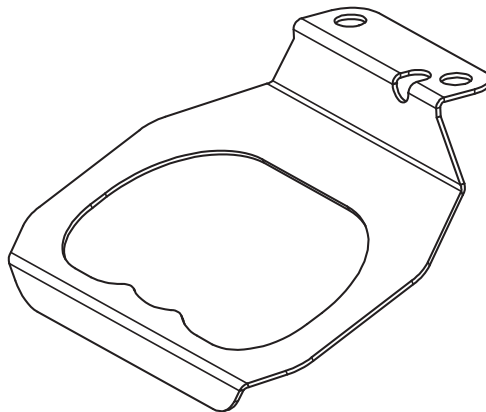

xx1500000253

### 2.5.2 Mechanically restricting the working range of axis 1

#### Mechanically restricting the working range

The information in this section is valid both for the floor and the suspended mounted robot.

The working range of axis 1 is limited by fixed mechanical stops. The working range can be reduced further by adding movable mechanical stops.

The mechanical turning range can be limited in steps of 22.5° from the synchronization position, between values defined in the table. The values differ depending on which design of the gearbox (and base) the robot is equipped with.

Design of gearbox	Limitation in mechanical turning range, calculated from synchronization position
other design than Type C and Type D	±129° to ±16.5° in steps of 22.5°



#### Note

The software working range limitations must be adjusted to correspond to the changes in the mechanical limitations of the working range. The system parameters that must be changed (*Upper joint bound* and *Lower joint bound*) are described in *Technical reference manual - System parameters*.

#### Required equipment

Equipment, etc.	Art. no.	Note
Mechanical stop, axis 1	See <a href="#">Spare part lists on page 403</a> .	Includes two additional stop lugs, attachment screws, washers and instruction
Attachment screw	See <a href="#">Spare part lists on page 403</a> .	2 pcs/stop lug Hex socket head cap screw M12x40, quality 8.8-A3F
Washer	See <a href="#">Spare part lists on page 403</a> .	2 pcs/lug 13x24x2.5
Standard toolkit		Content is defined in section <a href="#">Standard tools on page 398</a> .
Other tools and procedures may be required. See references to these procedures in the step-by-step instructions below.		These procedures include references to the tools required.

*Continues on next page*

## 2 Installation and commissioning

### 2.5.2 Mechanically restricting the working range of axis 1

Continued

#### Additional steps

The additional stops are fitted as shown in the figure.

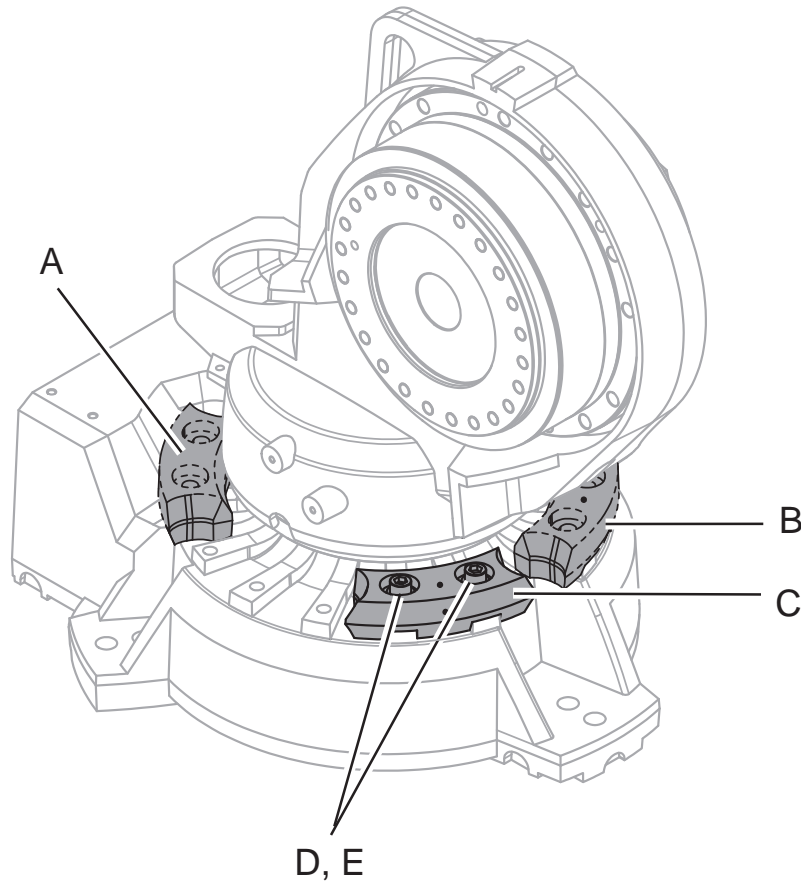

xx080000273

A	Movable mechanical stop. Limited to: <ul style="list-style-type: none"><li>• <math>-129^\circ</math></li></ul>
B	Movable mechanical stop. Limited to: <ul style="list-style-type: none"><li>• <math>+16.5^\circ</math></li></ul>
C	Movable mechanical stop. Limited to: <ul style="list-style-type: none"><li>• <math>-16.5^\circ</math></li></ul>
D	Attachment screws
E	Washers

#### Fitting, mechanical stop axis 1

How to fit the additional mechanical stop to the base is described in the procedure.

Mounting instructions are also supplied with the kit.

	Action	Note
1	Determine the position of the stop lugs.	See the figure <a href="#">Additional stops on page 84</a> for guidance.
2	Fit the stop lugs firmly with <i>attachment screws and washers</i> according to the figure <a href="#">Additional stops on page 84</a> .	Specified in <a href="#">Required equipment on page 83</a> . Tightening torque: 82 Nm

Continues on next page



#### Preparing the robot for working range $\pm 180^\circ$

This procedure describes how to prepare the robot for working range  $\pm 180^\circ$ .

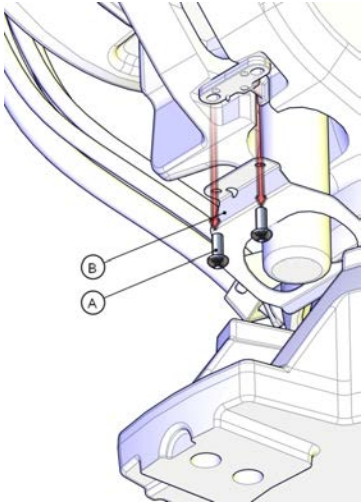
	Action	Note
1	 <p><b>DANGER</b></p> <p>Turn off all:</p> <ul style="list-style-type: none"> <li>• electric power supply</li> <li>• hydraulic pressure supply</li> </ul> <p>to the robot, before entering the robot working area.</p>	
2	<p>Remove the two screws holding the mechanical stop and the bracket.</p>	 <p>xx110000091</p> <p>A Attachment screw B Bracket, stop axis 1</p>
3	<p>Remove the bracket.</p>	
4	<p>Refit the attachment screws.</p>	
5	<p>Seal and paint the joints that have been opened. Also repair possible damages of the special Foundry Prime paint coat of the robot. See <a href="#">Cut the paint or surface on the robot before replacing parts on page 200</a>.</p>	

## 2 Installation and commissioning

---

### 2.6.1 Installing an expansion container

## 2.6 Installing options

### 2.6.1 Installing an expansion container

---

#### Validity of this section

This section is only valid for other design than Type C and Type D.

---

#### Introduction to the expansion container

The expansion container is needed on suspended robots (other design than Type C and Type D) to make sure that the amount of oil in gearbox axis 1 covers all important parts. Robots ordered as suspended robots (Option 224-2) have the expansion container installed on delivery.



#### Note

Manipulators delivered for floor mounting must have the option 224-2 added before changing mounting position to inverted.

Type C are not valid for inverted mounting.

*Continues on next page*

#### Expansion container

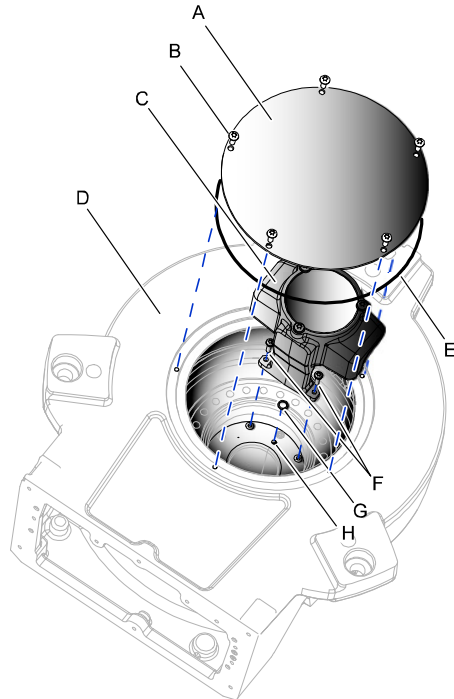

xx100000318

A	Cover
B	Attachment screw M6x16, quality 8.8-A2F (5 pcs)
C	Oil expansion container with cover
D	Base
E	O-ring D220x5
F	Attachment screw M5x20, quality 8.8-A2F and washer (2+2 pcs)
G	O-ring D1=9.5 D2=1.6
H	Oil plug (to be removed)

#### Required equipment

Equipment	Note
Expansion container	Kit including oil.
Lifting accessory	3HAC034766-001
Lifting instruction	Included with the lifting accessory.
Grease	-
Locking liquid	3HAB7116-1 Loctite 243
O-ring for base cover	Replace if damaged.

*Continues on next page*

## 2 Installation and commissioning

### 2.6.1 Installing an expansion container

*Continued*

#### Installing an expansion container

Use this procedure to install the expansion container.

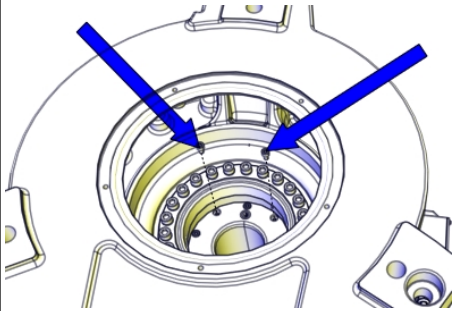
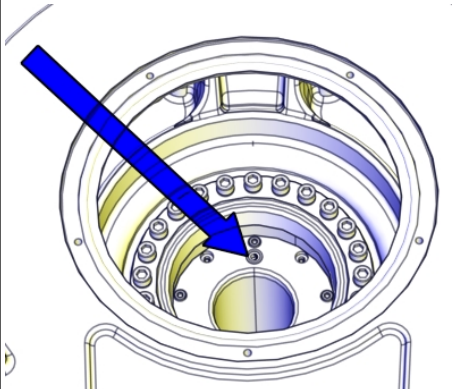
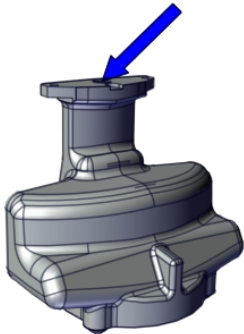

	Action	Information
1	Lift the robot using the lifting accessory and place it in suspended position with the base free for installation work.	See <a href="#">Lifting and turning a suspended mounted robot on page 60</a> .
2	Remove the <i>cover</i> and the <i>o-ring</i> from the <i>base</i> .	
3	Remove two existing <i>attachment screws</i> as shown in the figure.	 <p data-bbox="954 880 1066 898">xx1500001958</p> <p data-bbox="954 913 1407 972">The screws must be replaced with longer screws.</p>
4	Remove the <i>oil plug</i> from the base.	 <p data-bbox="954 1379 1066 1397">xx1900001818</p>
5	Fit a <i>plastic plug</i> in the expansion container drain hole.	 <p data-bbox="954 1794 1066 1812">xx1500001956</p>
6	Fill the expansion container with oil.	Oil volume: 0.4 l

*Continues on next page*

## 2 Installation and commissioning

### 2.6.1 Installing an expansion container

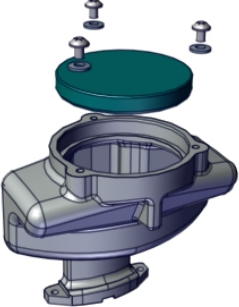
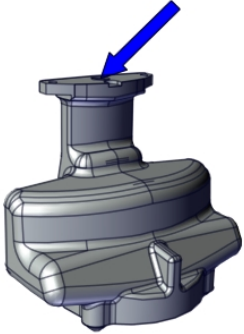
*Continued*

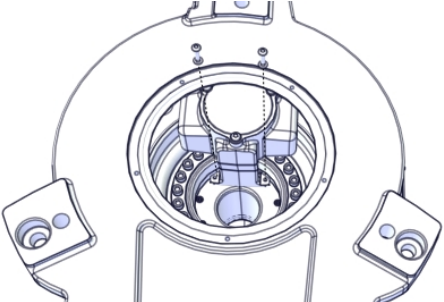
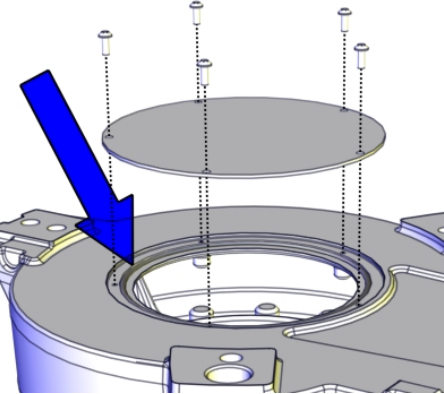
Action	Information
<p>7 Apply locking liquid to the three screw holes in the expansion container. Knock in the <i>VK-cover</i> with a rubber mallet. Secure with three screws and washers.</p>	<p>Locking liquid: 3HAB7116-1 (Loctite 243). Screws: M6x8 (3 pcs).</p>  <p>xx1500001957</p>
<p>8 Remove the <i>plastic plug</i>.</p> <p>9 Apply some grease on the small <i>o-ring</i> and place it in the recess on the expansion container.</p>	 <p>xx1500001956</p>
<p>10 Place the <i>expansion container</i> in the base and place it so the drain holes match.</p> <p> <b>Tip</b> Turn and install the container quickly to avoid oil spill.</p>	 <p>xx1500001959</p>
<p>11 Secure the expansion container with the <i>attachment screws</i> and <i>washers</i>. Wipe off any oil residuals before continuing.</p>	<p>Tightening torque 6 Nm.</p>
<p>12 Check the <i>o-ring</i> used on the cover. Replace it if damaged.</p>	<p>13 Refit the <i>cover</i> on the base with its <i>attachment screws</i>.</p>  <p>xx1900001819</p>

*Continues on next page*

## 2 Installation and commissioning

---

### 2.6.1 Installing an expansion container

*Continued*

	Action	Information
14	Turn the robot so it is not suspended.	
15	Turn the robot to suspended position.	
16	Inspect the oil level.	See procedure for suspended robot, <a href="#">Inspecting oil level, axis 1 gearbox on page 115</a> .

## 2.7 Robot in hot environments

### 2.7.1 Start of robot in hot environments





#### Introduction

This procedure describes how to start the robot in a hot environment. This procedure must be performed the first time the robot is started in a hot environment or if it has not been used for some time in a hot environment.

There is a possibility that some overpressure has been built up in the system. This overpressure must be released before starting up the robot.

#### Releasing overpressure in gearboxes

Use this procedure before the start of the robot in a hot environment to release potential overpressure being built up in gearboxes.

	Action	Note
1	 <b>DANGER</b> Turn off all: <ul style="list-style-type: none"> <li>• electric power supply</li> <li>• hydraulic pressure supply</li> </ul> to the robot, before entering the robot working area.	
2	 <b>CAUTION</b> Components may be hot.	
3	 <b>Note</b> Before opening the oil plug, make certain that the oil plug is above the oil level. Place the robot accordingly.	
4	Open oil plug filling <i>very carefully!</i>  <b>Note</b> Open the oil plug just enough for the overpressure to be released.	 <b>Tip</b> Hold a cloth or some paper over the oil plug while opening it to prevent surplus oil causing burns or other injuries.
5	Let the overpressure leave the gearbox.	
6	Refit the oil plug.	
7	Continue releasing the overpressure on all gearboxes.	

## 2 Installation and commissioning

---

### 2.8.1 Start of robot in cold environments

## 2.8 Robot in cold environments

### 2.8.1 Start of robot in cold environments

---

#### Introduction

This section describes how to start the robot in a cold environment if it is not starting the normal way.

---

#### Problems with starting the robot

##### Event message from Motion Supervision

Use this procedure if an event message indicates a problem with Motion supervision at start-up. More information about Motion Supervision is found in *Technical reference manual - System parameters*.

	Action	Note
1	Turn off Motion Supervision.	
2	Start the robot.	
3	When the robot has reached normal working temperature, the Motion Supervision can be turned on again.	

##### Robot stopping with other event message

Use this procedure if the robot is not starting.

	Action	Note
1	Start the robot with its normal program but with reduced speed.	The speed can be regulated with the RAPID instruction <code>VelSet</code> .

---

#### Adjusting the speed and acceleration during warm-up

Depending on how cold the environment is and what program is being used, the speed might need to be ramped up until reached maximum. The table shows examples of how to adjust the speed:

Work cycles	AccSet	Speed/velocity
3 Work cycles	20, 20	v100 (100 mm/s)
5 Work cycles	40, 40	v400 (400 mm/s)
5 Work cycles	60, 60	v600 (600 mm/s)
5 Work cycles	100, 100	v1000 (1000 mm/s)
More than 5 Work cycles	100, 100	Max.

If the program consists of large wrist movements, it is possible that the reorientation velocity, which is always high in predefined velocities, needs to be included in the ramping up.



## 2.9 Electrical connections

### 2.9.1 Robot cabling and connection points

#### Introduction

Connect the robot and controller to each other after securing them to the foundation. The lists below specify which cables to use for each respective application.



#### CAUTION

Connect the male and female connectors perfectly aligned horizontally to avoid any kind of tilt or skew.



#### CAUTION

Verify that the robot serial number is according to the number(s) in the *Declaration of Incorporation (DoI)*.

#### Main cable categories

All cables between the robot and controller are divided into the following categories:

Cable category	Description
Robot cables	Handles power supply to and control of the robot's motors as well as feedback from the serial measurement board. Specified in the table <a href="#">Robot cables on page 93</a> .
Customer cables (option)	Handles communication with equipment fitted on the robot by the customer, low voltage signals and high voltage power supply + protective ground. The customer cables also handle databus communication. See the product manual for the controller, see document number in <a href="#">References on page 10</a> .
External axes cables (option)	Handles power supply to and control of the external axes' motors as well as feedback from the servo system. See <i>Application manual - Additional axes and stand alone controller (IRC5)</i> , document number in <a href="#">References on page 10</a> .

#### Robot cables

These cables are included in the standard delivery. They are completely pre-manufactured and ready to plug in.

Cable sub-category	Description	Connection point, cabinet	Connection point, robot
Robot cable, power	Transfers drive power from the drive units in the control cabinet to the robot motors.	XS1 (IRC5 controllers) X1 (OmniCore controllers)	R1.MP

*Continues on next page*

## 2 Installation and commissioning

### 2.9.1 Robot cabling and connection points

*Continued*

Cable sub-category	Description	Connection point, cabinet	Connection point, robot
Robot cable, signals	Transfers resolver data from and power supply to the serial measurement board.	XS2 (IRC5 controllers) X2 (OmniCore controllers)	R1.SMB

#### Robot cable, power

Cable	Art. no.
Robot cable, power: 7 m	3HAC026787-001
Robot cable, power: 15 m	3HAC026787-002
Robot cable, power: 22 m	3HAC026787-003
Robot cable, power: 30 m	3HAC026787-004

#### Robot cable, signals

Cable	Art. no.
Robot cable signal, shielded: 7 m	3HAC068917-001
Robot cable signal, shielded: 15 m	3HAC068918-001
Robot cable signal, shielded: 22 m	3HAC068919-001
Robot cable signal, shielded: 30 m	3HAC068920-001

#### Bending radius for static floor cables

The minimum bending radius is 10 times the cable diameter for static floor cables.

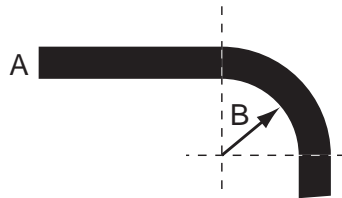

xx1600002016

A	Diameter
B	Diameter x10

*Continues on next page*

#### Grounding and bonding point on manipulator

There is a grounding/bonding point on the manipulator base. The grounding/bonding point is used for potential equalizing between control cabinet, manipulator and any peripheral devices.

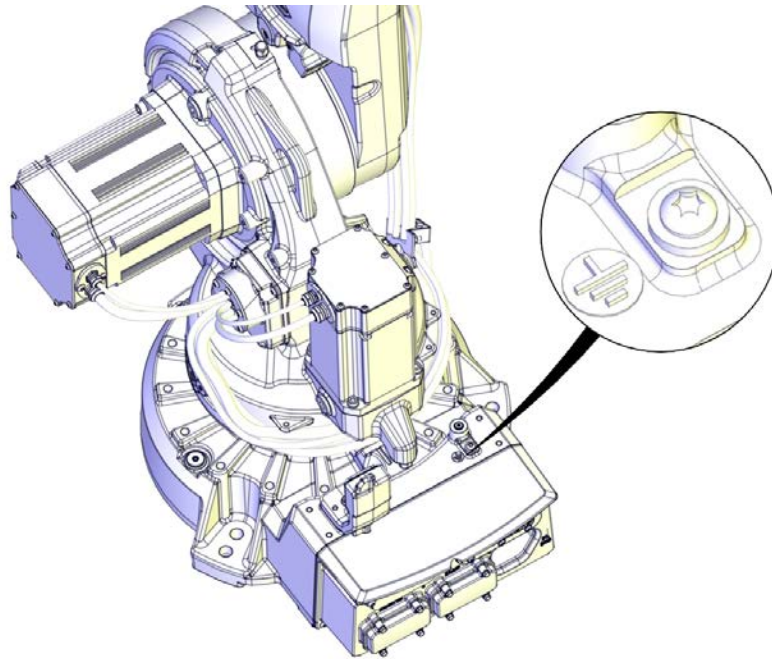

xx1600001004

## 2 Installation and commissioning

### 2.9.2 Customer connection on robot

#### 2.9.2 Customer connection on robot

##### Location of customer connection

For the connection of extra equipment to the robot, cables and air hose are integrated into the robot's cabling, and there can be two UTOW71210SH06 and one UTOW71626SH06 connector on the front part of the upper arm.



##### Note

The maximum leakage current for attached equipment must not exceed 10mA.

The customer connections are located on the robot as shown in the figure.

##### Customer connections on upper arm

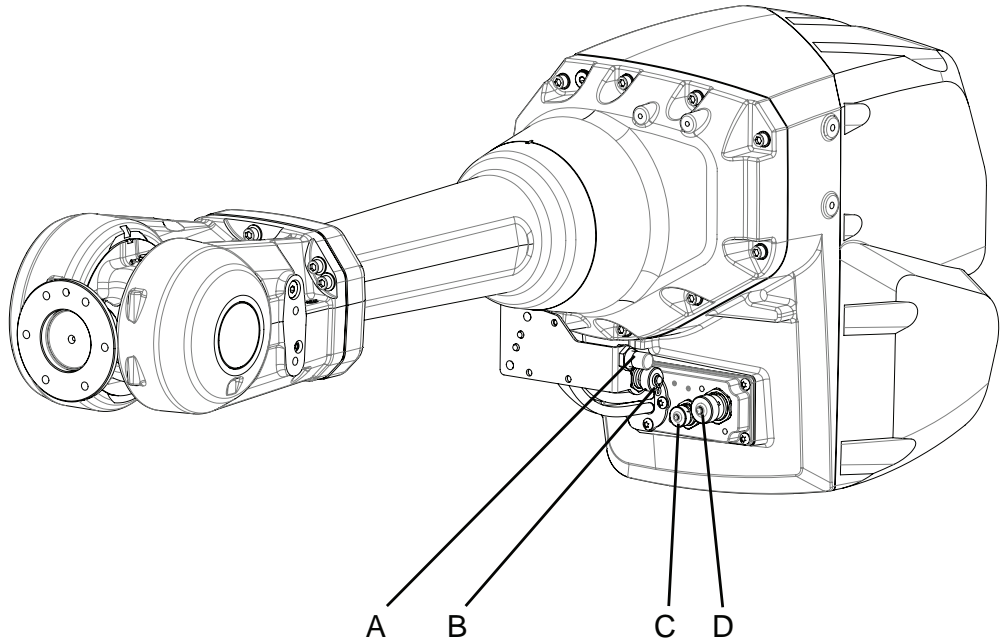

xx2000001659

A	R2.PROC1 Air M16x1.5 (24° cone sealing)
B	R2.ETHERNET <sup>i</sup>
C	R2.CP or R2.CBUS
D	R2.CS or R2.CP/CS

<sup>i</sup> Use a straight ethernet connector. Using an angled connector causes a collision risk with R2.CP, R2.CBUS or R2.CP/CS.

*Continues on next page*

#### Customer connections on upper arm with signal lamp

The figure shows the customer connections on the upper arm, including the optional signal lamp that can be fitted to the arm house.

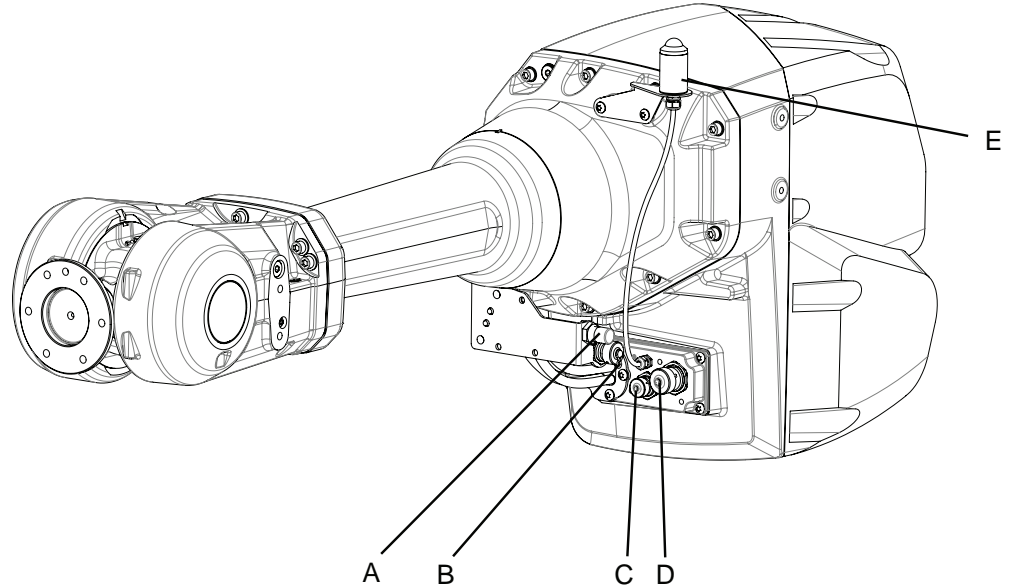

xx2000001660

A	R2.PROC1 Air M16x1.5 (24° cone sealing)
B	R2.ETHERNET <sup>i</sup>
C	R2.CP or R2.CBUS
D	R2.CS or R2.CP/CS
E	Signal lamp
-	R3.H1 +, R3.H2 - (inside the arm house, not shown in figure)

<sup>i</sup> Use a straight ethernet connector. Using an angled connector causes a collision risk with R2.CP, R2.CBUS, R2.CS or R2.CP/CS.

## 2 Installation and commissioning

### 2.9.2 Customer connection on robot

Continued

#### Customer connections base

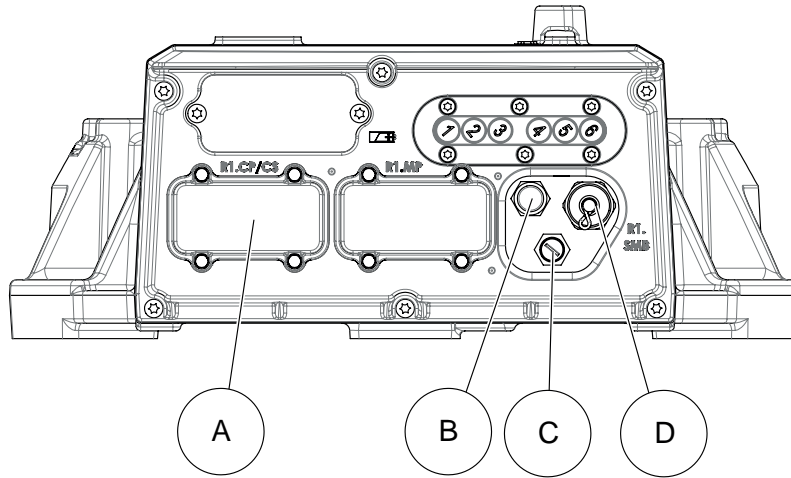

xx2000001636

A	R1.CP/CS
B	R1.PROC1 (Air M16x1.5)
C	R1.ETHERNET
D	R1.SMB

#### Customer connections base with 7th axis

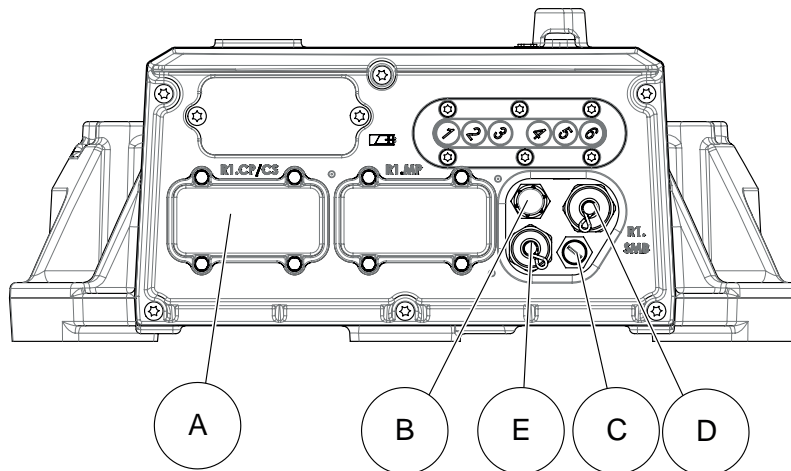

xx2000001637

A	R1.CP/CS
B	R1.PROC1 (Air M16x1.5)
C	R1.ETHERNET
D	R1.SMB
E	R2.FB7

Continues on next page

#### Extra equipment connections

Connections to the:

- air hose ( 3/8") is located on the front part of the upper arm and at the base. Max. 8 bar. Inner diameter of the air hose: 9.5 mm.

Number of signals, customer connections option Parallel&Air (803-1):

- 23 (50V, 0.5A)
- 9 (300V, 2A). 8 are double crimped in R1.CP/CS and 1 is only accessible in the robot base.
- 1 protective ground

Number of signals, customer connections option Ethernet, Parallel&Air (803-2) and DeviceNet, Parallel&Air (803-3):

- 8 (50V, 0.5A)
- 3 (300V, 2A)
- 2 DeviceNet
- 4 EtherNet
- 1 protective ground

Number of signals, customer connections option Profibus, Parallel&Air (803-4):

- 8 (50V, 0.5A)
- 2 (300V, 2A)
- 2 Profibus
- 1 protective ground

#### Connection sets

To connect power and signal conductors to the robot base/upper arm connectors, the following parts are recommended.

Connection set	Connector	Art. no.	Content
PROC1 on base	R1.CP/CS	3HAC16667-1	<ul style="list-style-type: none"> <li>• Sockets for cable area of 0.14-2.5 mm<sup>2</sup></li> <li>• Hood foundry</li> <li>• Hinged frame, hood</li> <li>• Multicontact-module, female</li> </ul>
Connector set on base	R1.ETHER-NET	3HAC033181-001	<ul style="list-style-type: none"> <li>• Hose coupling</li> <li>• M12 connector, male</li> </ul>
R2.CP/R2.CS	R2.CP/R2.CS	3HAC025396-001	<ul style="list-style-type: none"> <li>• Pins for cable area 0.21 - 0.93 mm<sup>2</sup></li> <li>• Bottle shaped shrinking hose</li> <li>• Angle shaped shrinking hose</li> <li>• Hose coupling</li> </ul>
Connector set upper arm	R2.ETHER-NET	3HAC070439-001	<ul style="list-style-type: none"> <li>• Pins for cable area 0.21 - 0.93 mm<sup>2</sup></li> <li>• Bottle shaped shrinking hose</li> <li>• Angle shaped shrinking hose</li> </ul>

*Continues on next page*

## 2 Installation and commissioning

### 2.9.2 Customer connection on robot

Continued

#### Power supply connections on the robot

Signal name	Customer Terminal Controller	Customer Contact on Upper arm, R2	Customer Contact on robot base (cable between robot and controller not supplied)
CPA	XP6.1	R2.CP.A	R1.CP/CS.d1
CPB	XP6.2	R2.CP.B	R1.CP/CS.d6
CPC	XP6.3	R2.CP.C	R1.CP/CS.d3
CPD	XP6.4	R2.CP.D	R1.CP/CS.d4
CPE	XP6.1	R2.CP.E	R1.CP/CS.d1
CPF	XP6.2	R2.CP.F	R1.CP/CS.d6
CPG		R2.CP.G (Earth)	
CPH	-	R2.CP.H	R1.CP/CS.d7
CPJ	XP6.3	R2.CP.J	R1.CP/CS.d3
CPK	XP6.4	R2.CP.K	R1.CP/CS.d4

#### Signal connection on the robot

Signal name	Customer Terminal Controller	Customer Contact on Upper arm, R2	Customer Contact on robot base (cable between robot and controller not supplied)
CSA	XP5.1.1	R2.CS.A	R1.CP/CS.b1
CSB	XP5.1.2	R2.CS.B	R1.CP/CS.b2
CSC	XP5.2.1	R2.CS.C	R1.CP/CS.b3
CSD	XP5.2.2	R2.CS.D	R1.CP/CS.b4
CSE	XP5.2.3	R2.CS.E	R1.CP/CS.b5
CSF	XP5.2.4	R2.CS.F	R1.CP/CS.b6
CSG	XP5.1.9	R2.CS.G	R1.CP/CS.b7
CSH	XP5.1.10	R2.CS.H	R1.CP/CS.b8
CSJ	XP5.1.11	R2.CS.J	R1.CP/CS.b9
CSK	XP5.1.12	R2.CS.K	R1.CP/CS.b10
CSL	XP5.1.3	R2.CS.L	R1.CP/CS.b11
CSM	XP5.1.4	R2.CS.M	R1.CP/CS.b12
CSN	XP5.1.5	R2.CS.N	R1.CP/CS.b13
CSP	XP5.1.6	R2.CS.P	R1.CP/CS.b14
CSR	XP5.3.1	R2.CS.R	R1.CP/CS.b15
CSS	XP5.3.2	R2.CS.S	R1.CP/CS.b16
CST	XP5.3.3	R2.CS.T	R1.CP/CS.b18
CSU	XP5.3.4	R2.CS.U	R1.CP/CS.b19
CSV	XP5.3.5	R2.CS.V	R1.CP/CS.b20
CSW	XP5.3.6	R2.CS.W	R1.CP/CS.b21
CSX	XP5.2.9	R2.CS.X	R1.CP/CS.b22

Continues on next page



## 2 Installation and commissioning

### 2.9.2 Customer connection on robot

*Continued*

Signal name	Customer Terminal Controller	Customer Contact on Upper arm, R2	Customer Contact on robot base (cable between robot and controller not supplied)
CSY	XP5.2.10	R2.CS.Y	R1.CP/CS.b23
CSZ	XP5.2.11	R2.CS.Z	R1.CP/CS.b24

## 2 Installation and commissioning

### 2.10.1 Installation of IRB 4600 Foundry Prime in a water jet application

## 2.10 Additional installation (Foundry Prime)

### 2.10.1 Installation of IRB 4600 Foundry Prime in a water jet application

#### General

Robots delivered with the Foundry Prime protection are specially designed to work in water jet cleaning cells with 100% humidity and alkaline detergent. To ensure that the protection offers the best reliability, some measures are needed during installation of the robot according to the procedures below.



#### Note

For best reliability, it is also of highest importance that the special maintenance instructions for the Foundry Prime robot are followed and documented.

#### Commissioning

- Never switch off the overpressure in motors and serial measurement compartment during cooling down of robot after it has been switched off.
- When turning off an cleaning cell we recommend that the humid air inside a cell is ventilated out, to avoid that the humid air is sucked into e.g. gearboxes due to the raised vacuum when cooled down.

#### Environmental conditions

Humidity	100%
Washing detergent with pH	<9.0
Washing detergent must contain rust inhibitor and be approved by ABB.	
Cleaning bath temperature	<60°C, used in a typical waterjet cleaning application at suitable speed.

#### Air specification for pressurizing of robot

The air must be dry and clean, such as instrument air. Following table details the air specification.

Dew point	<+2°C at 6 bar
Solid particle size	<5 microns
Oil content	<1 ppm (1 mg/m <sup>3</sup> )
Pressure to robot	0.2 - 0.3 bar



#### WARNING

If the pressurized air contains oil, it could result in a brake failure in the motors and cause the robot arms to fall down, leading to personal injury or physical damage.

*Continues on next page*

## 2 Installation and commissioning

### 2.10.1 Installation of IRB 4600 Foundry Prime in a water jet application

*Continued*



#### WARNING

If the air pressure exceeds the specified, it could result in a brake failure in the motors and cause the robot arms to fall down, leading to personal injury or physical damage.



#### Note

To secure sufficient air pressure, it is recommended to use a pressure sensor.

#### Pressurize the motors and serial measurement board cavity

The robots are prepared with hoses to the motors and the serial measurement board cavity to enable pressurizing of them.



#### WARNING

The robot must be pressurized also when it is switch off, to avoid that the humid environmental air is sucked into the motors when cooling down.

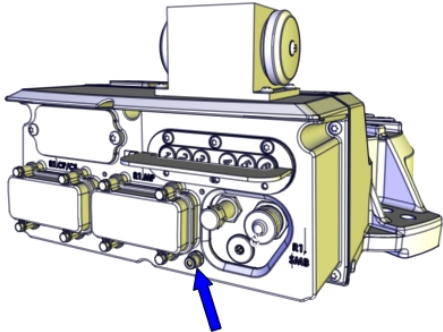
	Action	Note/Illustration
1	Connect a compressed air hose to air connector on robot base, see illustration.	 <p data-bbox="991 1406 1098 1429">xx1500002398</p> <p data-bbox="991 1444 1273 1473">Dimension: G1/8, d=6mm</p>
2	Protect the screws on the Harting connectors on the robot base from corrosion with Mercasol.	Do this when the controller cables are connected.
3	Pressurize the robot.	See <a href="#">Air specification for pressurizing of robot on page 102</a> for correct pressure.
4	Inspect the air system.	See <a href="#">Inspection of air hoses (Foundry Prime) on page 148</a> .

#### Protecting from high pressure water



#### WARNING

No part of the robot are allowed to be exposed to direct high pressure jet of water. The sealings between the moving parts on the wrist must not be exposed to direct or rebounding high-pressure jet of water.

*Continues on next page*

## 2 Installation and commissioning

### 2.10.1 Installation of IRB 4600 Foundry Prime in a water jet application

*Continued*

#### Protecting the wrist joints

The sealings between the moving parts on the wrist must not be exposed to direct high-pressure water. We recommend that the gripper include a shield that prevents direct water flush on the sealing surfaces of the wrist. The sealings are pointed out in the illustration below.

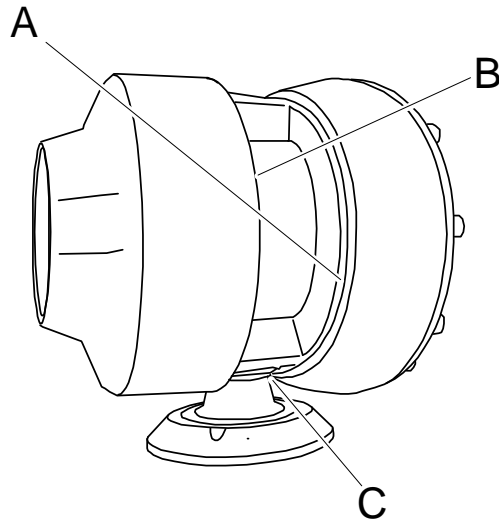

xx0600003108

A	Axis 5, bearing support side
B	Axis 5, bearing gear side
C	Axis 6, mounting flange - gear house

#### Protecting the wrist flange from corrosion

The mounting surface on the wrist flange is protected with grease. The joint between the wrist flange and the tool and the screw holes on the wrist flange must be protected.

Action	Note/Illustration
<p>1 After mounting the tool, clean the following surfaces from grease:</p> <ul style="list-style-type: none"> <li>• the visible surface (not painted)</li> <li>• the rear end of the screw holes and end of screws.</li> </ul>	<p>xx0600003109</p> <p>A screw holes and screws B unpainted surface</p>
2 Protect these surfaces with Mercasol.	

*Continues on next page*

## 2 Installation and commissioning

### 2.10.1 Installation of IRB 4600 Foundry Prime in a water jet application

*Continued*

	Action	Note/Illustration
3	Before running the robot in a water jet cleaning cell: <ul style="list-style-type: none"><li>perform a inspection of the pressure in motors and SMB cavity.</li></ul>	<i>Inspection of air hoses (Foundry Prime) on page 148</i>

## 2 Installation and commissioning

---

### 2.10.2 Commissioning (Foundry Prime)

#### 2.10.2 Commissioning (Foundry Prime)

---

##### General

The following should be taken in consideration when running a robot in a water jet application cell:



##### CAUTION

Never switch off the overpressure in motors and serial measurement compartment during cooling down of robot after it has been switched off.



##### Note

To reduce the risk for corrosion due to condensation in gearboxes, it is required that the robot is running with high speed on each axes at least on one occasion each hour. This is to lubricate the gearbox cavities.



##### Note

When turning off a cleaning cell we recommend that the humid air is ventilated out from the cell, to avoid that the humid air is sucked into gearboxes for example, due to the raised vacuum when cooled down.

#### 2.11 Test run after installation, maintenance, or repair

##### Safe handling

Use the following procedure after installation, maintenance, or repair, before initiating motion.



#### DANGER

Initiating motion without fulfilling the following aspects, may increase the risk for injury or cause damage to the robot.

	Action
1	Remove all tools and foreign objects from the robot and its working area.
2	Verify that the robot is properly secured to its position by all screws, before it is powered up.
3	Verify that any safety equipment installed to secure the position or restrict the robot motion during service activity is removed.
4	Verify that the fixture and work piece are well secured, if applicable.
5	Verify that all safety equipment is installed, as designed for the application.
6	Verify that no personnel are inside the safeguarded space.
7	If maintenance or repair has been done, verify the function of the part that was maintained.
8	Verify the application in the operating mode manual reduced speed.

##### Collision risks



#### CAUTION

When programming the movements of the robot, always identify potential collision risks before initiating motion.

Mechanical stops will not always stop the movements of the robot completely.

**This page is intentionally left blank**



---

## 3 Maintenance

### 3.1 Introduction

---

#### Structure of this chapter

This chapter describes all the maintenance activities recommended for the IRB 4600 Foundry Prime.

It is based on the maintenance schedule found at the beginning of the chapter. The schedule contains information about required maintenance activities including intervals, and refers to procedures for the activities.

Each procedure contains all the information required to perform the activity, including required tools and materials.

The procedures are gathered in different sections and divided according to the maintenance activity.

---

#### Safety information

Observe all safety information before conducting any service work.

There are general safety aspects that must be read through, as well as more specific safety information that describes the danger and safety risks when performing the procedures. Read the chapter [Safety on page 19](#) before performing any service work.

The maintenance must be done by qualified personnel in accordance with the safety requirements set forth in the applicable national and regional standards and regulations.

**Note**

If the IRB 4600 Foundry Prime is connected to power, always make sure that the IRB 4600 Foundry Prime is connected to protective earth and a residual current device (RCD) before starting any maintenance work.

For more information see:

- *Product manual - OmniCore V250XT*
- *Product manual - IRC5*
- *Product manual - IRC5 Panel Mounted Controller*
- [Robot cabling and connection points on page 93.](#)

## 3 Maintenance

---

### 3.2 Introduction for Foundry Prime robots

### 3.2 Introduction for Foundry Prime robots

---

#### Introduction

The Foundry Prime robots are designed for installation and operation in very hard environments. Misuse of the robots, as well as poor installation, cleaning, maintenance, and repair can be harmful for the functioning of the robot.

To eliminate these risks appropriate equipment and procedures are required when installing, cleaning, maintaining, and repairing ABB Foundry Prime robots.

An extended maintenance program including service activities and schedule is required.

Cleaning and maintenance of robots with Foundry Prime protection shall be performed by trained personnel.

---

#### Specific maintenance activities and intervals for Foundry Prime

The Foundry Prime robots have specific maintenance activities and intervals compared to standard robots:

- More comprehensive
- More frequent
- Sample activities for check of lubrication
- Conditional - for example, water content in gearbox control/decide replacement intervals

Preventive measures every 6 months secure the uptime of the robot:

- Inspection of oil level in gearboxes
  - Surface treatment
  - Cable harness
- 

#### Activity to lubricate gearboxes cavities and gears

Run each axis on high speed at least one occasion per hour. This activity will lubricate the gearbox cavities and gears, which reduce the risk for corrosion due to condensation in gearboxes.

---

#### Non-predictable situations

Non-predictable situations also give rise to inspections of the robot. Any damage must be attended to immediately.



#### Note

Repair damages on painted surfaces as soon as possible. Use the touch-up kit 3HAC035355-001 for Foundry Prime protection.

---

#### Warranty claims

Warranty claims for defect products due to misuse or failure to fulfil operational and maintenance requirements will not be approved.

---

## 3.3 Maintenance schedule

### 3.3.1 Specification of maintenance intervals

---

#### Introduction

The intervals are specified in different ways depending on the type of maintenance activity to be carried out and the working conditions of the IRB 4600 Foundry Prime:

- Calendar time: specified in months regardless of whether the system is running or not.
- Operating time: specified in operating hours. More frequent running means more frequent maintenance activities.
- SIS: specified by the robot's SIS (Service Information System). A typical value is given for a typical work cycle, but the value will differ depending on how hard each part is run.

The SIS used in M2004 is further described in the *Operating manual - Service Information System (IRC5)* or *Operating manual - OmniCore*.

The SIS used in OmniCore is further described in the *Operating manual - OmniCore*.

Robots with the functionality *Service Information System* activated can show active counters in the device browser in RobotStudio, or on the FlexPendant.

---

#### Overhaul

Depending on application and operational environment a complete overhaul may be necessary in average around 40000 hours.

ABB Connected Services and its Assessment tools can help you to identify the real stress level of your robot, and define the optimal ABB support to maintain your robot working.

Contact your local ABB Customer Service to get more information.

## 3 Maintenance

### 3.3.2 Maintenance schedule

### 3.3.2 Maintenance schedule

#### General

The robot must be maintained regularly to ensure proper function. The maintenance activities and intervals are specified in the table below.

Non-predictable situations also give rise to inspections of the robot. Any damages must be attended to immediately!

The inspection intervals *do not* specify the life of each component.

Values for these are specified in the section [Expected component life on page 114](#)



#### Note

For best reliability, it is of highest importance that the special maintenance instructions for the Foundry Prime robot are followed and documented.

#### Activities and intervals, Foundry Prime

The following table specifies the required maintenance activities and intervals for robots with protection type Foundry Prime.

Maintenance activity	Equipment	Interval
Inspection	Oil level in axis-1 gearbox	Every: <ul style="list-style-type: none"><li>• 6 months</li></ul>
Inspection	Oil level in axis-2 gearbox	Every: <ul style="list-style-type: none"><li>• 6 months</li></ul>
Inspection	Oil level in axis-3 gearbox	Every: <ul style="list-style-type: none"><li>• 6 months</li></ul>
Inspection	Oil level in axis-4 gearbox	Every: <ul style="list-style-type: none"><li>• 6 months</li></ul>
Inspection	Oil level in axis-5 gearbox	Every: <ul style="list-style-type: none"><li>• 6 months</li></ul>
Inspection	Oil level in axis-6 gearbox	Every: <ul style="list-style-type: none"><li>• 6 months</li></ul>
Inspection	Surface treatment	Every: <ul style="list-style-type: none"><li>• 6 months <sup>i</sup></li></ul>
Inspection	Cable harness (Including rubber blocks and straps)	Every: <ul style="list-style-type: none"><li>• 6 months</li></ul> If required <sup>ii</sup>
Replacement	Cable harness	If required <sup>ii</sup>
Inspection	Air hoses	Every: <ul style="list-style-type: none"><li>• 6 months</li></ul>
Inspection	Information labels	Every: <ul style="list-style-type: none"><li>• 12 months</li></ul>
Inspection	Dampers	Every: <ul style="list-style-type: none"><li>• 12 months</li></ul>
Inspection	Mechanical stop, axis 1	Every: <ul style="list-style-type: none"><li>• 12 months</li></ul>

*Continues on next page*

Maintenance activity	Equipment	Interval
Analysis	Oil gearbox axis 6	Every: <ul style="list-style-type: none"> <li>• 3,000 hours or 6 months, whichever occurs first <sup>iii</sup></li> </ul>
Changing <sup>iv</sup>	Oil in axis-1 gearbox	Every: <ul style="list-style-type: none"> <li>• 6,000 hours</li> </ul>
Changing <sup>iv</sup>	Oil in axis-2 gearbox	Every: <ul style="list-style-type: none"> <li>• 6,000 hours</li> </ul>
Changing <sup>iv</sup>	Oil in axis-3 gearbox	Every: <ul style="list-style-type: none"> <li>• 6,000 hours</li> </ul>
Changing <sup>iv</sup>	Oil in axis-4 gearbox	Every: <ul style="list-style-type: none"> <li>• 12,000 hours</li> </ul>
Changing <sup>iv</sup>	Oil in axis-5 & -6 gearbox	Every: <ul style="list-style-type: none"> <li>• 3,000 hours or 6 months, whichever occurs first.</li> </ul>
Replacement	Battery pack, measurement system of type RMU101 or RMU102 (3-pole battery contact)	36 months or battery low alert <sup>v</sup>
Replacement	Battery pack, measurement system with 2-pole battery contact, e.g. DSQC633A	Battery low alert <sup>vi</sup>
Overhaul	Robot	40,000 hours
Overhaul	Axis-6 gearbox	Every: <ul style="list-style-type: none"> <li>• 24 months</li> </ul>

- <sup>i</sup> Damage to painted surfaces must be repaired as soon as possible to avoid corrosion.
- <sup>ii</sup> The warranty does not apply to effects or wear caused by environmental factors.
- <sup>iii</sup> Analyse the water content in oil in gearbox axis 6 first time after 3,000 hours or 6 months. If the working conditions changes, analyse again after 3,000 hours or 6 months.
- <sup>iv</sup> Before changing oil, always check the oil level. Always analyze the water content in the exchanged oil, according to [Analyzing the water content in gearbox oil on page 188](#), to determine the condition of each gearbox.  
If the water content in oil is more than 3%, analyze the new oil within 2 months. Repeatedly high water content in oil indicates wear of radial sealing in the gearbox.
- <sup>v</sup> The battery low alert (38213 **Battery charge low**) is displayed when the battery needs to be replaced. The recommendation to avoid an unsynchronized robot is to keep the power to the controller turned on until the battery is to be replaced.  
See the replacement instruction for more details.
- <sup>vi</sup> The battery low alert (38213 **Battery charge low**) is displayed when remaining backup capacity (robot powered off) is less than 2 months. The typical lifetime of a new battery is 36 months if the robot is powered off 2 days/week or 18 months if the robot is powered off 16 h/day. The lifetime can be extended with a battery shutdown service routine. See *Operating manual - IRC5 with FlexPendant* or *Operating manual - OmniCore* for instructions.

## 3 Maintenance

### 3.3.3 Expected component life

### 3.3.3 Expected component life

#### General

The expected life of a specific component of the robot can vary greatly depending on how hard it is run.



#### Note

For expected component life of Foundry Prime robots see [Expected component life - protection type Foundry Prime on page 114](#).

#### Expected component life - protection type Standard

Component	Expected life	Note
Cable harness Normal usage <sup>i</sup>	40,000 hours <sup>ii</sup>	Not including: <ul style="list-style-type: none"><li>• Possible SpotPack harnesses</li><li>• Optional upper arm harnesses</li></ul>
Cable harness Extreme usage <sup>iii</sup>	20,000 hours <sup>ii</sup>	Not including: <ul style="list-style-type: none"><li>• Possible SpotPack harnesses</li><li>• Optional upper arm harnesses</li></ul>
Gearboxes <sup>iv</sup>	40,000 hours	

<sup>i</sup> Examples of "normal usage" in regard to movement: most material handling applications.

<sup>ii</sup> Severe chemical or thermal environments, or similar environments, can result in shortened life expectancy.

<sup>iii</sup> Examples of "extreme usage" in regard to movement: press tending, very severe palletizing applications, major use of axis 1 movement.

<sup>iv</sup> Depending on application, the lifetime can vary. The Service Information System (SIS), integrated in the robot software, can be used as a guidance for planning service of gearbox for the individual robot. This applies to gearboxes on axes 1, 2 and 3. The lifetime of gearbox axes 4, 5 and 6 is not calculated by SIS (See the *Operating manual - Service Information System*) In applications such as Foundry or Washing the robot can be exposed to chemicals, high temperature or humidity which can have an effect on the lifetime of gearboxes. Contact the local *ABB Robotics Service team* for more information.

The SIS for an IRC5 system is described in the *Operating manual - Service Information System*.

#### Expected component life - protection type Foundry Prime

The demanding nature of using Foundry Prime robots in a washing application, can shorten the life of the robot's components compared to that of standard robots in a typical robotic application. See [Expected component life - protection type Standard on page 114](#) for standard robots. Depending on the actual washing application, the life of an individual robot can vary or being reduced.

The life of Foundry Prime robots in washing applications will depend on a number of factors. The most important factors are:

- the washing detergent used
- the ambient environment
- installation, maintenance, and repair procedures
- the operation cycle of the robot.

## 3.4 Inspection activities

### 3.4.1 Inspecting oil level, axis 1 gearbox

#### Mounting position of the robot

If the robot is floor mounted, follow the procedures in [Inspecting the gearbox oil level in a floor mounted robot on page 116](#).

If the robot is suspended, follow the procedures in [Inspecting the gearbox oil level in a suspended robot on page 118](#).

#### Required equipment

Equipment	Note
Oil plug sealing washer, gearbox	3HAC029646-001
Lubrication oil	See section <a href="#">Type of lubrication in gearboxes on page 151</a> .
Standard toolkit	Content is defined in section <a href="#">Standard tools on page 398</a> .
Other tools and procedures may be required. See references to these procedures in the step-by-step instructions below.	These procedures include references to the tools required.

#### Additional equipment - Foundry Prime

Equipment	Art. no.	Note
Rust preventive	3HAC034903-001	Mercasol
Sikaflex 521FC	3HAC026759-001	
Loctite 574	12340011-116	
Brush		
Foundry Prime touch up kit	3HAC035355-001	

*Continues on next page*

### 3 Maintenance

#### 3.4.1 Inspecting oil level, axis 1 gearbox

*Continued*

#### Inspecting the gearbox oil level in a floor mounted robot

Location of oil plugs (floor mounted)

The axis 1 gearbox is located between the frame and base of the robot. The oil plug for inspection is shown in the figure.

**Old design:**

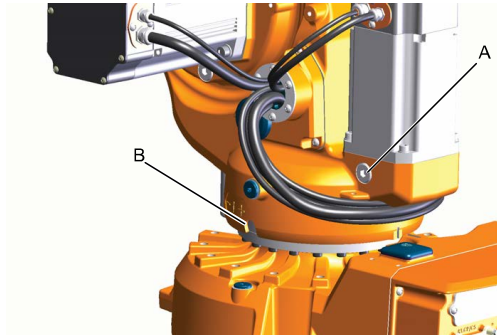

xx080000304

A	Oil plug, inspection
B	Oil plug, gearbox

**Current design:**

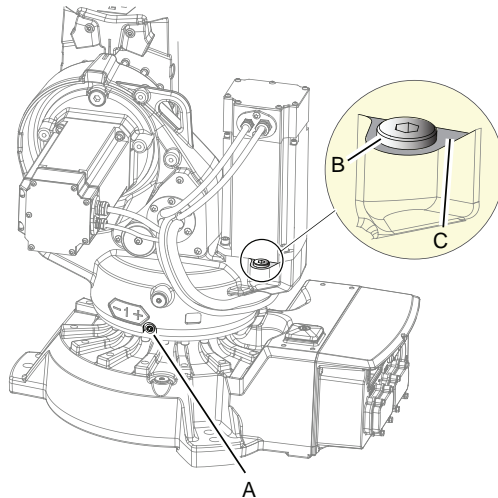

xx100000669



A	Oil plug draining, on gearbox
B	Oil plug filling, on surface for motor flange
C	Surface for motor flange

*Continues on next page*



#### Inspecting oil level, axis-1 gearbox (floor mounted)

Use this procedure to inspect the oil level in the axis-1 gearbox, when the robot is floor mounted.

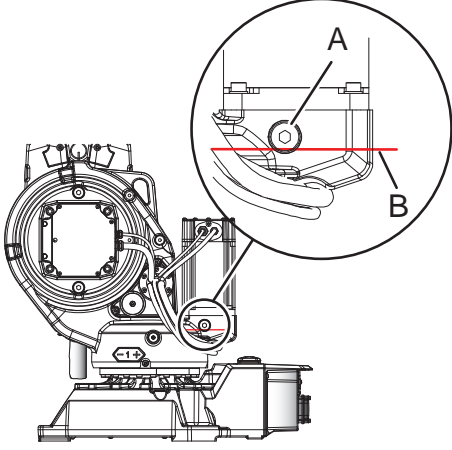
	Action	Note
1	 <b>WARNING</b> Handling gearbox oil involves several safety risks, see <a href="#">Gearbox lubricants (oil or grease) on page 34</a> .	
2	 <b>DANGER</b> Turn off all: <ul style="list-style-type: none"> <li>• electric power supply</li> <li>• hydraulic pressure supply</li> </ul> to the robot, before entering the robot working area.	
3	 <b>CAUTION</b> The gearbox can contain an <i>excess of pressure</i> that can be hazardous. Open the oil plug carefully in order to let out the excess pressure.	
4	Open the <i>oil plug, inspection</i> .	See <a href="#">Location of oil plugs (floor mounted) on page 116</a> .
5	<b>Old design:</b> Measure the oil level by looking into the hole of the oil plug inspection. Required oil level: <ul style="list-style-type: none"> <li>• 0-5 mm, up to the lower edge of the oil plug hole of the oil plug inspection.</li> </ul>	 <p>xx120000859</p> <p>Parts:                      A Oil plug inspection                      B Approximate oil level</p>

*Continues on next page*

### 3 Maintenance

#### 3.4.1 Inspecting oil level, axis 1 gearbox

Continued

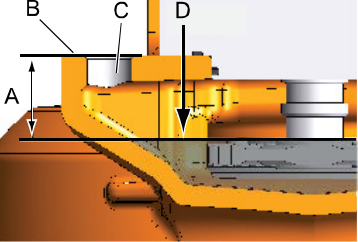
	Action	Note
6	<p><b>Current design:</b>            Measure the oil level at the oil plug hole.            Required oil level:</p> <ul style="list-style-type: none"> <li>• 35 ± 3 mm below the surface for the motor flange.</li> </ul> <p>The oil level shall only just start to be observed when looking through the oil filling hole. See figure!</p>	 <p>xx100000824</p> <p><b>Parts:</b></p> <ul style="list-style-type: none"> <li>• A: 35 ± 3 mm</li> <li>• B: Surface for motor flange</li> <li>• C: Filling hole</li> <li>• D: Oil level</li> </ul>
7	Add oil if required.	<p>How to fill oil is described in section:</p> <ul style="list-style-type: none"> <li>• <a href="#">Changing the oil, axis 1 gearbox on floor mounted robots on page 153</a></li> </ul>
8	Refit the oil plug, inspection.	<p>Tightening torque:</p> <ul style="list-style-type: none"> <li>• 24 Nm</li> </ul>
9	<p>Seal and paint the joints that have been opened. Also repair possible damages of the special Foundry Prime paint coat of the robot. See <a href="#">Cut the paint or surface on the robot before replacing parts on page 200</a>.</p>	

#### Inspecting the gearbox oil level in a suspended robot

Location of oil plugs (suspended)

Old design:

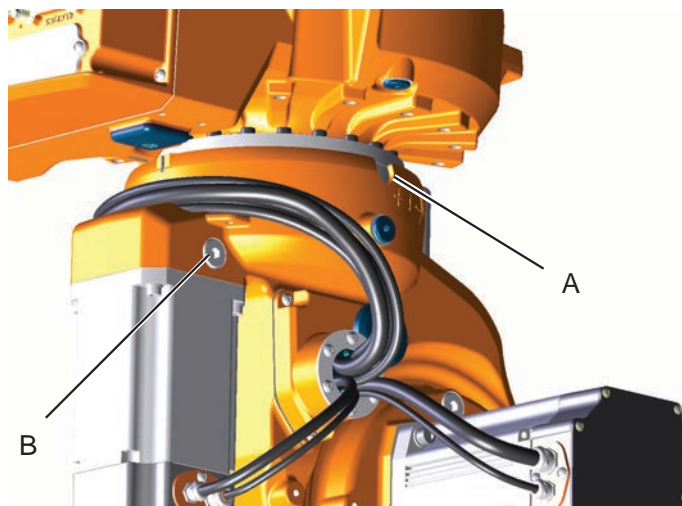

xx120000883

A	Oil plug, filling
B	Oil plug, draining

Continues on next page

**Current design:**

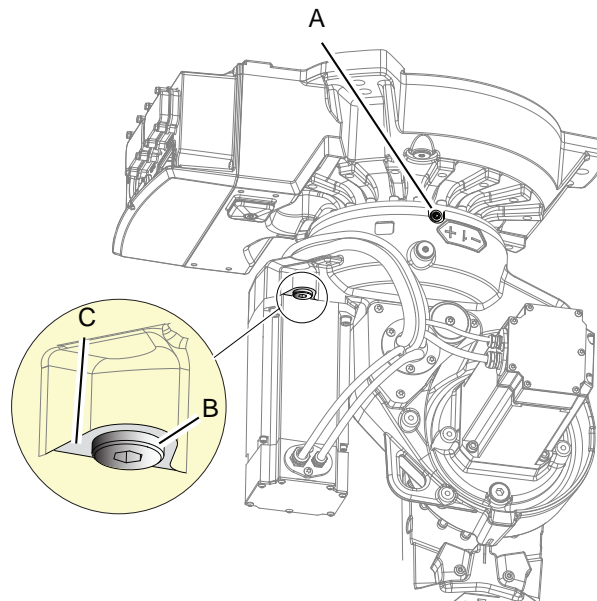

xx1000001436

A	Filling oil plug, on gearbox
B	Draining oil plug, on surface for motor flange
C	Surface for motor flange

#### Inspecting oil level, axis-1 gearbox (suspended robot)

Use this procedure to inspect the oil level in the axis-1 gearbox, when the robot is suspended.



**Note**

If the axis-1 gearbox is filled with an amount of oil suited for an inverted position, the oil level can only be inspected in the inverted position! If the robot was taken down to stand on the floor, the oil level would be above the oil plug hole, which would result in oil leakage if the plug would be opened while robot stands on the floor!





	Action	Note
1	<p><b>WARNING</b> Handling gearbox oil involves several safety risks, see <a href="#">Gearbox lubricants (oil or grease) on page 34</a>.</p>	

*Continues on next page*

### 3 Maintenance

#### 3.4.1 Inspecting oil level, axis 1 gearbox

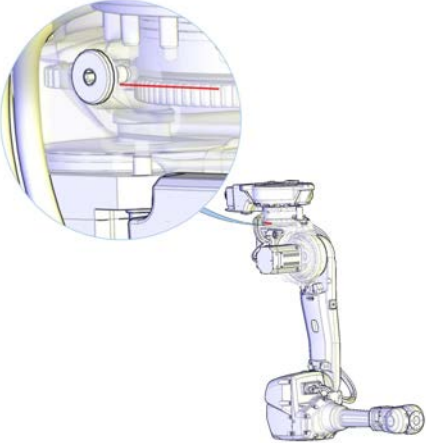
Continued

	Action	Note
2	<p> <b>DANGER</b></p> <p>Turn off all:</p> <ul style="list-style-type: none"> <li>• electric power supply</li> <li>• hydraulic pressure supply</li> </ul> <p>to the robot, before entering the robot working area.</p>	
3	<p> <b>CAUTION</b></p> <p>The gearbox can contain an <i>excess of pressure</i> that can be hazardous. Open the oil plug carefully in order to let out the excess pressure.</p>	
4	<p>Open the <i>oil plug inspection</i> on the axis 1 gearbox.</p>	<p>See the figure in:</p> <ul style="list-style-type: none"> <li>• <a href="#">Location of oil plugs (floor mounted) on page 116</a></li> </ul>
5	<p>Required oil level:</p> <ul style="list-style-type: none"> <li>• up to the lower edge of the oil plug hole.</li> </ul> <p> <b>Note</b></p> <p>The oil plugs on gearbox axis 1 are now on top.</p>	 <p>xx1100000008</p>
6	<p>Add oil if required.</p>	<p>How to fill oil is described in section:</p> <ul style="list-style-type: none"> <li>• <a href="#">Changing the oil, axis 1 gearbox on floor mounted robots on page 153</a></li> </ul>
7	<p>Refit the oil plug.</p> <p> <b>Note</b></p> <p>Before refitting the oil plug in the gearbox, always replace the oil plug sealing washer with a new one. If not there is a risk of leakage.</p>	<p>Tightening torque:</p> <ul style="list-style-type: none"> <li>• 3-8 Nm</li> </ul>
8	<p>Seal and paint the joints that have been opened. Also repair possible damages of the special Foundry Prime paint coat of the robot. See <a href="#">Cut the paint or surface on the robot before replacing parts on page 200</a>.</p>	

### 3.4.2 Inspecting the oil level, axis 2 gearbox

#### Location of axis 2 gearbox

The axis 2 gearbox is located in the lower arm rotational center, underneath the motor attachment. The oil plugs are shown in the figure.

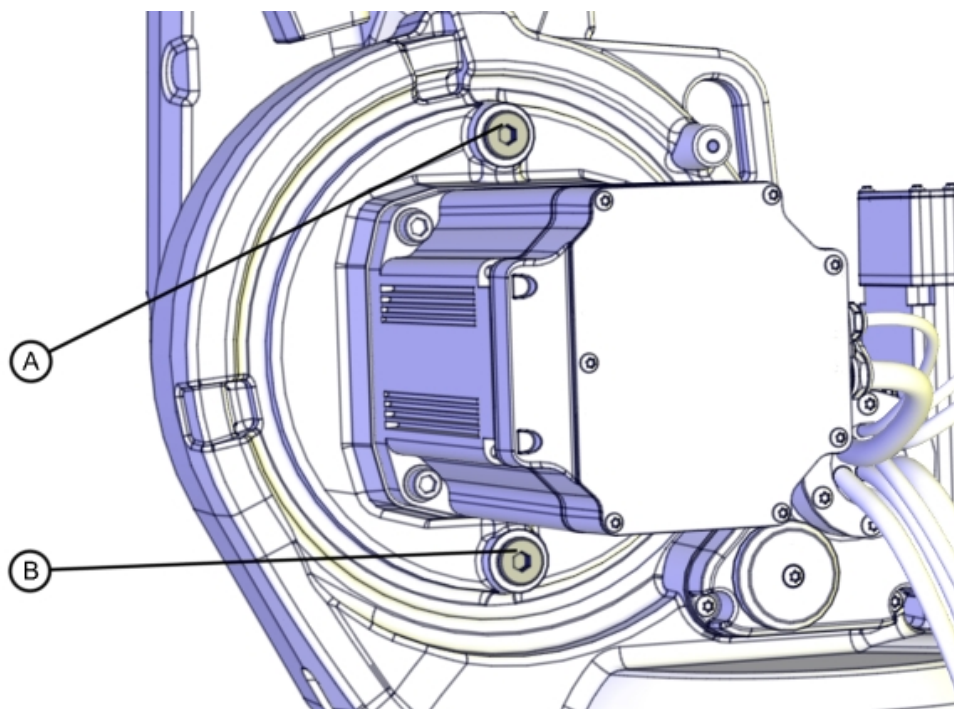

xx080000305

A	Oil plug, filling
B	Oil plug, draining (Quick connect fitting)

#### Required equipment

Equipment	Note
Oil plug sealing washer, gearbox	3HAC029646-001
Lubrication oil	See section <i>Type of lubrication in gearboxes on page 151</i> .
Oil plug (Quick connect fitting)	For article number see <i>Spare part lists on page 403</i> .
Standard toolkit	Content is defined in section <i>Standard tools on page 398</i> .
Other tools and procedures may be required. See references to these procedures in the step-by-step instructions below.	These procedures include references to the tools required.

#### Additional equipment - Foundry Prime

Equipment	Art. no.	Note
Rust preventive	3HAC034903-001	Mercasol

*Continues on next page*

### 3 Maintenance





#### 3.4.2 Inspecting the oil level, axis 2 gearbox

Continued

Equipment	Art. no.	Note
Sikaflex 521FC	3HAC026759-001	
Loctite 574	12340011-116	
Brush		
Foundry Prime touch up kit	3HAC035355-001	

#### Inspecting oil level, axis 2 gearbox

Use this procedure to inspect the oil level in the axis 2 gearbox.

	Action	Note
1	 <b>WARNING</b> Handling gearbox oil involves several safety risks, see <a href="#">Gearbox lubricants (oil or grease) on page 34</a> .	
2	 <b>DANGER</b> Turn off all: <ul style="list-style-type: none"> <li>• electric power supply</li> <li>• hydraulic pressure supply</li> </ul> to the robot, before entering the robot working area.	
3	 <b>CAUTION</b> The gearbox can contain an <i>excess of pressure</i> that can be hazardous. Open the oil plug carefully in order to let out the excess pressure.	
4	 <b>CAUTION</b> Always cut the paint with a knife and grind the paint edge when disassembling parts. See <a href="#">Cut the paint or surface on the robot before replacing parts on page 200</a> .	
5	Open the <i>oil plug, inspection</i> (location depends on how the robot is mounted).  <b>Note</b> Always open the oil plug on top, depending how the robot is mounted.	See the figure in: <ul style="list-style-type: none"> <li>• <a href="#">Location of axis 2 gearbox on page 121</a></li> </ul>
6	Measure the oil level at the oil plug hole. Required oil level: <ul style="list-style-type: none"> <li>• 42 mm ± 5 mm below the lower edge of the oil plug hole.</li> </ul>	

Continues on next page

	Action	Note
7	Add oil if required.	How to fill oil is described in section <ul style="list-style-type: none"> <li>• <a href="#">Changing the oil, axis-2 gearbox on page 165</a></li> </ul>
8	Refit the oil plug.  <b>Note</b> Before refitting the oil plug in the gearbox, always replace the oil plug sealing washer with a new one. If not there is a risk of leakage.	Tightening torque: <ul style="list-style-type: none"> <li>• 24 Nm</li> </ul>
9	Seal and paint the joints that have been opened. Also repair possible damages of the special Foundry Prime paint coat of the robot. See <a href="#">Cut the paint or surface on the robot before replacing parts on page 200</a> .	

## 3 Maintenance

### 3.4.3 Inspecting the oil level, axis 3 gearbox

### 3.4.3 Inspecting the oil level, axis 3 gearbox

#### Location of axis 3 gearbox

The axis 3 gearbox is located in the upper arm rotational center, underneath the motor attachment. The oil plug for inspection is shown in the figure.

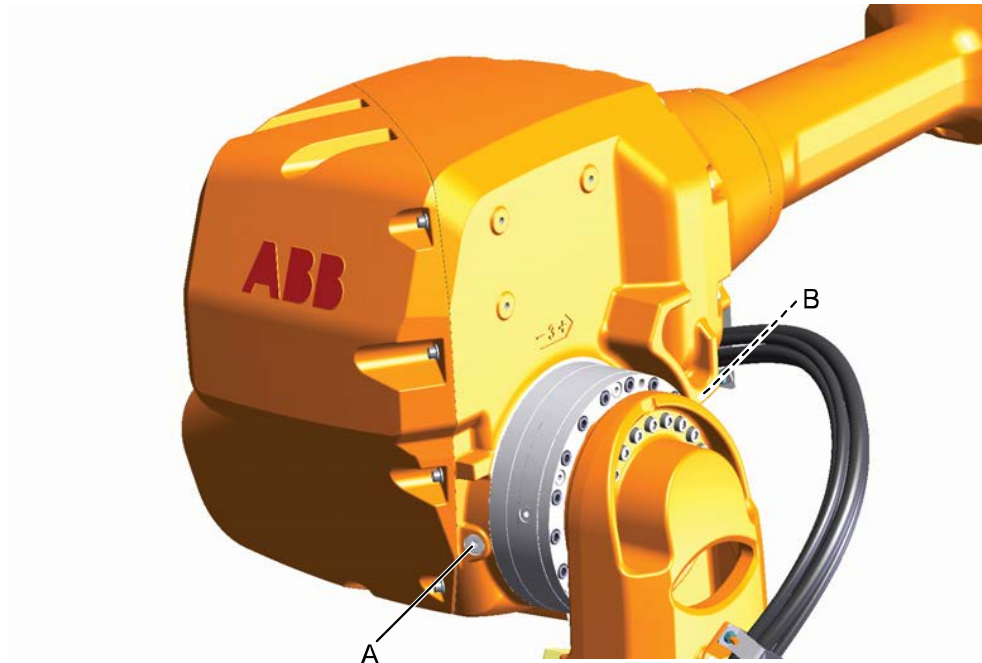

xx0800000306

A	Oil plug, armhouse
B	Oil plug, gearbox (not visible in this figure)

#### Required equipment

Equipment	Note
Lubrication oil	See section <a href="#">Type of lubrication in gearboxes on page 151</a> .
Standard toolkit	Content is defined in section <a href="#">Standard tools on page 398</a> .
Other tools and procedures may be required. See references to these procedures in the step-by-step instructions below.	These procedures include references to the tools required.

#### Additional equipment - Foundry Prime





Equipment	Art. no.	Note
Rust preventive	3HAC034903-001	Mercasol
Sikaflex 521FC	3HAC026759-001	
Loctite 574	12340011-116	
Brush		
Foundry Prime touch up kit	3HAC035355-001	

*Continues on next page*



## Inspecting the oil level, axis 3 gearbox

Use this procedure to inspect the oil level in the axis 3 gearbox.

	Action	Note
1	 <b>WARNING</b> Handling gearbox oil involves several safety risks, see <a href="#">Gearbox lubricants (oil or grease) on page 34</a> .	
2	Move the robot to where the upper arm is placed in a +30° position.	
3	 <b>DANGER</b> Turn off all: <ul style="list-style-type: none"> <li>• electric power supply</li> <li>• hydraulic pressure supply</li> </ul> to the robot, before entering the robot working area.	
4	 <b>CAUTION</b> The gearbox can contain an <i>excess of pressure</i> that can be hazardous. Open the oil plug carefully in order to let out the excess pressure.	
5	 <b>CAUTION</b> Always cut the paint with a knife and grind the paint edge when disassembling parts. See <a href="#">Cut the paint or surface on the robot before replacing parts on page 200</a> .	
6	Open the <i>oil plug, armhouse</i> .	See the figure in: <ul style="list-style-type: none"> <li>• <a href="#">Location of axis 3 gearbox on page 124</a></li> </ul>
7	Measure the oil level at the oil plug hole. Required oil level: <ul style="list-style-type: none"> <li>• oil in the gearbox shall be just below the edge of the oil plug hole.</li> </ul>	
8	Add oil if required.	How to fill oil is described in section: <ul style="list-style-type: none"> <li>• <a href="#">Changing the oil, axis-3 gearbox on page 169</a></li> </ul>
9	Refit the oil plug.	Tightening torque: <ul style="list-style-type: none"> <li>• in armhouse: 10 Nm</li> <li>• in gearbox: 3 Nm</li> </ul>
10	Seal and paint the joints that have been opened. Also repair possible damages of the special Foundry Prime paint coat of the robot. See <a href="#">Cut the paint or surface on the robot before replacing parts on page 200</a> .	

### 3 Maintenance

#### 3.4.4 Inspecting the oil level, axis 4 gearbox

#### 3.4.4 Inspecting the oil level, axis 4 gearbox

##### Location of axis 4 gearbox

The axis 4 gearbox is located in the upper armhouse. The oil plug is shown in the figure.

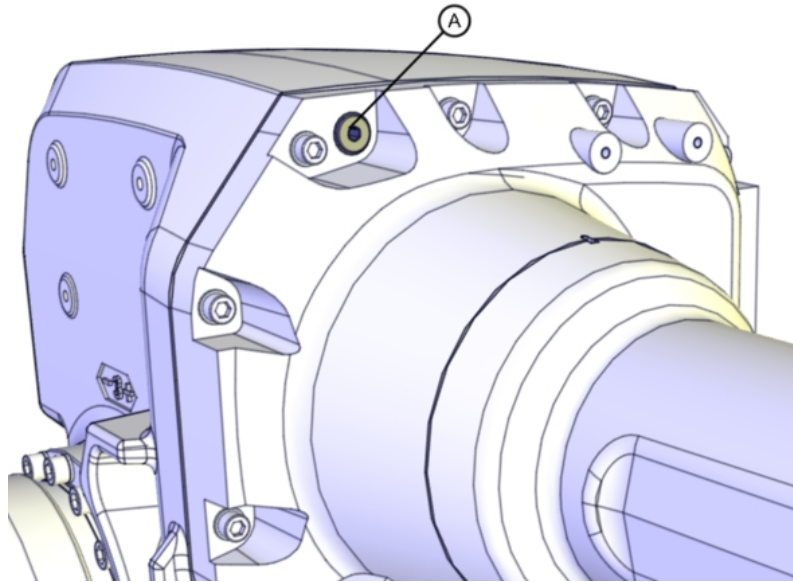

xx080000307

A	Oil plug, for filling and draining
---	------------------------------------

##### Required equipment

Equipment	Note
Lubrication oil	See section <a href="#">Type of lubrication in gearboxes on page 151</a> .
Standard toolkit	Content is defined in section <a href="#">Standard tools on page 398</a> .
Other tools and procedures may be required. See references to these procedures in the step-by-step instructions below.	These procedures include references to the tools required.





##### Additional equipment - Foundry Prime

Equipment	Art. no.	Note
Rust preventive	3HAC034903-001	Mercasol
Sikaflex 521FC	3HAC026759-001	
Loctite 574	12340011-116	
Brush		
Foundry Prime touch up kit	3HAC035355-001	

*Continues on next page*

## Inspecting the oil level, axis 4 gearbox

Use this procedure to inspect the oil level in the axis 4 gearbox.

	Action	Note
1	 <b>WARNING</b> Handling gearbox oil involves several safety risks, see <a href="#">Gearbox lubricants (oil or grease) on page 34</a> .	
2	Move the robot to where the upper arm points straight up and the oil plug hole is on top of the axis 4 gearbox.	
3	 <b>DANGER</b> Turn off all: <ul style="list-style-type: none"> <li>• electric power supply</li> <li>• hydraulic pressure supply</li> </ul> to the robot, before entering the robot working area.	
4	 <b>CAUTION</b> The gearbox can contain an <i>excess of pressure</i> that can be hazardous. Open the oil plug carefully in order to let out the excess pressure.	
5	 <b>CAUTION</b> Always cut the paint with a knife and grind the paint edge when disassembling parts. See <a href="#">Cut the paint or surface on the robot before replacing parts on page 200</a> .	
6	Open the <i>oil plug</i> .	See the figure in: <ul style="list-style-type: none"> <li>• <a href="#">Location of axis 4 gearbox on page 126</a></li> </ul>
7	Measure the oil level at the oil plug hole. Required oil level: <ul style="list-style-type: none"> <li>• 35 ± 5 mm below the oil plug flange.</li> </ul>	
8	Add oil if required.	How to fill oil is described in section: <ul style="list-style-type: none"> <li>• <a href="#">Changing the oil, axis-4 gearbox on page 175</a></li> </ul>
9	Refit the oil plug, filling.	Tightening torque: <ul style="list-style-type: none"> <li>• 10 Nm</li> </ul>
10	Seal and paint the joints that have been opened. Also repair possible damages of the special Foundry Prime paint coat of the robot. See <a href="#">Cut the paint or surface on the robot before replacing parts on page 200</a> .	

### 3 Maintenance

#### 3.4.5 Inspecting oil level, gearbox axes 5 - 6

#### 3.4.5 Inspecting oil level, gearbox axes 5 - 6

##### Location of gearbox, axes 5-6

The gearbox axes 5-6 is located in the wrist unit. The oil plug is shown in the figure.

The figure shows IRB 4600 -60/2.05

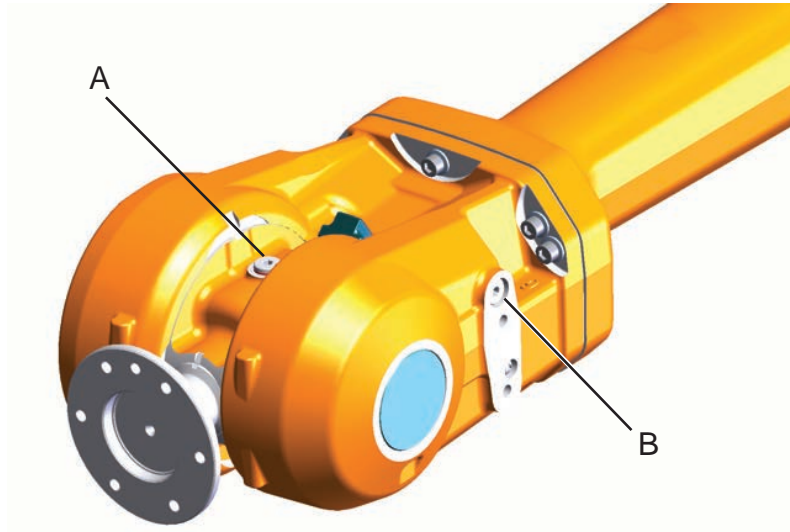

xx0800000308

A	Oil plug, tilthouse
B	Oil plug, wrist (also used as air inlet when draining from oil plug A)

##### Required equipment

Equipment	Note
Lubrication oil	See section <a href="#">Type of lubrication in gearboxes on page 151</a> .
Standard toolkit	Content is defined in section <a href="#">Standard tools on page 398</a> .
Other tools and procedures may be required. See references to these procedures in the step-by-step instructions below.	These procedures include references to the tools required.





##### Additional equipment - Foundry Prime

Equipment	Art. no.	Note
Rust preventive	3HAC034903-001	Mercasol
Sikaflex 521FC	3HAC026759-001	
Loctite 574	12340011-116	
Brush		
Foundry Prime touch up kit	3HAC035355-001	

*Continues on next page*

**Inspecting oil level, gearbox axes 5-6 - wrist 60 kg**

Use this procedure to inspect the oil level in gearbox axes 5-6.

	Action	Note
1	 <b>WARNING</b> Handling gearbox oil involves several safety risks, see <a href="#">Gearbox lubricants (oil or grease) on page 34</a> .	
2	Move the robot to where the upper arm is placed in its calibration position.	
3	 <b>DANGER</b> Turn off all: <ul style="list-style-type: none"> <li>• electric power supply</li> <li>• hydraulic pressure supply</li> </ul> to the robot, before entering the robot working area.	
4	 <b>CAUTION</b> The gearbox can contain an <i>excess of pressure</i> that can be hazardous. Open the oil plug carefully in order to let out the excess pressure.	
5	 <b>CAUTION</b> Always cut the paint with a knife and grind the paint edge when disassembling parts. See <a href="#">Cut the paint or surface on the robot before replacing parts on page 200</a> .	
6	Open the <i>oil plug, wrist</i> .	See the figure in: <ul style="list-style-type: none"> <li>• <a href="#">Location of gearbox, axes 5-6 on page 128</a></li> </ul>
7	Required oil level: <ul style="list-style-type: none"> <li>• 3 ±3 mm below the edge of the oil plug hole.</li> </ul>	 <b>Note</b> Open the <i>oil plug, tilthouse</i> when inspecting. This will level up oil in axes 5 and 6. See the figure in: <ul style="list-style-type: none"> <li>• <a href="#">Inspecting oil level, gearbox axes 5 - 6 on page 128</a></li> </ul>
8	Add <i>oil</i> if required.	How to fill oil is described in section: <ul style="list-style-type: none"> <li>• <a href="#">Changing oil, axes-5 and -6 gearboxes on page 179</a></li> </ul>
9	Refit the oil plugs.	Tightening torque: <ul style="list-style-type: none"> <li>• 10 Nm</li> </ul>

Continues on next page

### 3 Maintenance





#### 3.4.5 Inspecting oil level, gearbox axes 5 - 6

Continued

	Action	Note
10	Seal and paint the joints that have been opened. Also repair possible damages of the special Foundry Prime paint coat of the robot. See <a href="#">Cut the paint or surface on the robot before replacing parts on page 200</a> .	

#### Inspecting oil level, gearbox axes 5-6 alternative method - wrist 60 kg

Use this procedure to inspect the oil level in gearbox axes 5-6 as an alternative method.

	Action	Note
1	 <b>WARNING</b> Handling gearbox oil involves several safety risks, see <a href="#">Gearbox lubricants (oil or grease) on page 34</a> .	
2	Move the robot to where the upper arm is placed in its calibration position.	
3	Move the upper arm (axis 3) to a horizontal position, then rotate (axis 4) +90°.	This will put the <i>oil plug, wrist</i> on top. See the figure in: <ul style="list-style-type: none"> <li><a href="#">Location of gearbox, axes 5-6 on page 128</a></li> </ul>  <b>Note</b> In this position it is <b>not</b> possible to open the <i>oil plug, tilthouse</i> , in order to level up oil in axes 5 and 6!
4	 <b>DANGER</b> Turn off all: <ul style="list-style-type: none"> <li>electric power supply</li> <li>hydraulic pressure supply</li> </ul> to the robot, before entering the robot working area.	
5	 <b>CAUTION</b> The gearbox can contain an <i>excess of pressure</i> that can be hazardous. Open the oil plug carefully in order to let out the excess pressure.	
6	 <b>CAUTION</b> Always cut the paint with a knife and grind the paint edge when disassembling parts. See <a href="#">Cut the paint or surface on the robot before replacing parts on page 200</a> .	

Continues on next page

	Action	Note
7	Open the <i>oil plug, wrist</i> .	See the figure in: <ul style="list-style-type: none"> <li>• <a href="#">Location of gearbox, axes 5-6 on page 128</a></li> </ul>
8	Required oil level: <ul style="list-style-type: none"> <li>• 63 ±3 mm below the edge of the oil plug hole.</li> </ul>	
9	Add oil if required.	How to fill oil is described in section: <ul style="list-style-type: none"> <li>• <a href="#">Changing oil, axes-5 and -6 gearboxes on page 179</a></li> </ul>
10	Refit <i>oil plug, wrist</i> .	Tightening torque: <ul style="list-style-type: none"> <li>• 10 Nm</li> </ul>
11	Seal and paint the joints that have been opened. Also repair possible damages of the special Foundry Prime paint coat of the robot. See <a href="#">Cut the paint or surface on the robot before replacing parts on page 200</a> .	

### 3 Maintenance

#### 3.4.6 Inspecting the cable harness

#### 3.4.6 Inspecting the cable harness

##### Location of cable harness

The figure shows the location of the cable harness.

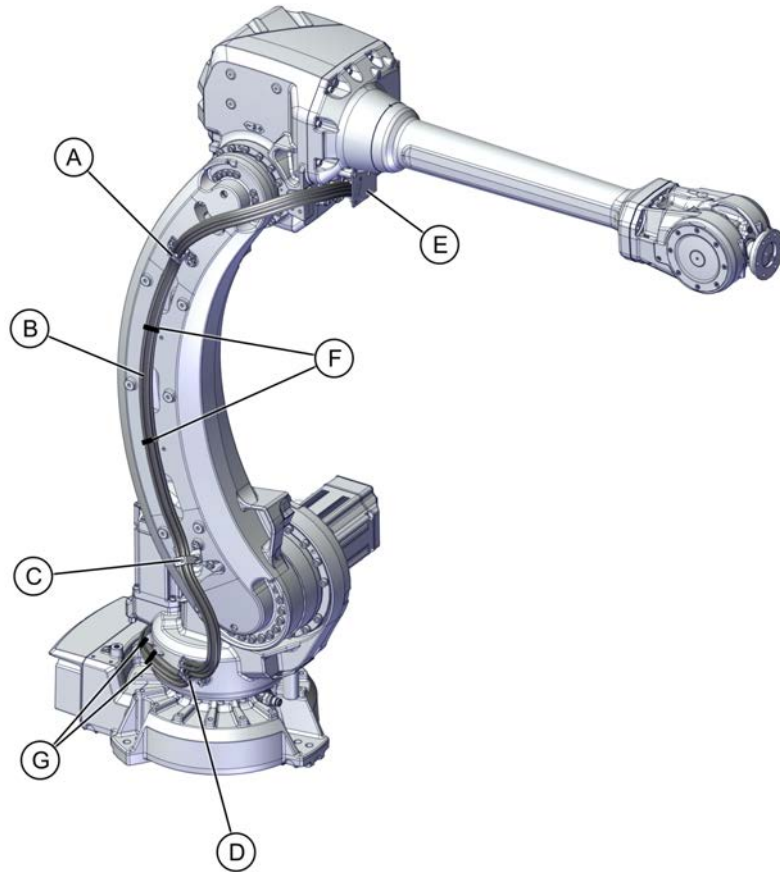

xx220000803

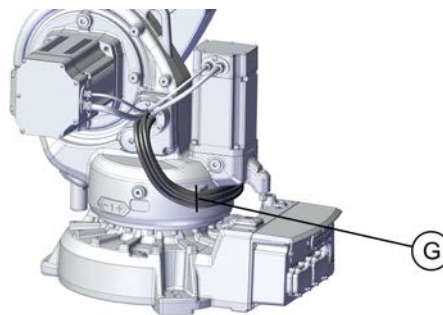

xx220000804

A	Bracket, lower arm
B	Cable harness
C	Bracket, lower arm
D	Bracket, frame
E	Bracket, arm house

*Continues on next page*



F	Cable strap plastic, lower arm 2 pcs
G	Cable straps steel 3 pcs

#### Required equipment

Equipment	Note
Standard toolkit	Content is defined in section <a href="#">Standard tools on page 398</a> .
Other tools and procedures may be required. See references to these procedures in the step-by-step instructions below.	These procedures include references to the tools required.
Circuit diagram	See chapter <a href="#">Circuit diagram on page 405</a> .

#### Additional equipment - Foundry Prime

Equipment	Art. no.	Note
Rust preventive	3HAC034903-001	Mercasol
Sikaflex 521FC	3HAC026759-001	
Loctite 574	12340011-116	
Brush		
Foundry Prime touch up kit	3HAC035355-001	

#### Inspecting the cable harness

Use this procedure to inspect the cable harness. The inspection points are shown in the figure [Location of cable harness on page 132](#)

	Action	Note
1	 <b>DANGER</b> Turn off all: <ul style="list-style-type: none"> <li>• electric power supply</li> <li>• hydraulic pressure supply</li> </ul> to the robot, before entering the robot working area.	
2	Make an overall visual inspection of the cable harness in order to detect wear or damage.	
3	Check the <i>connectors at the base</i> .	
4	Check the <i>connectors at the armhouse</i> .	
5	Check all <i>brackets and straps</i> are properly attached to the robot.	
6	Replace the cable harness if wear, cracks or damage is detected.	How to replace the cable harness is described in <a href="#">Repair on page 193</a> .
7	Seal and paint the joints that have been opened. Also repair possible damages of the special Foundry Prime paint coat of the robot. See <a href="#">Cut the paint or surface on the robot before replacing parts on page 200</a> .	

## 3 Maintenance

### 3.4.7 Inspecting information labels

#### 3.4.7 Inspecting information labels

##### Location of information labels

The figure shows the location of the information labels to be inspected.

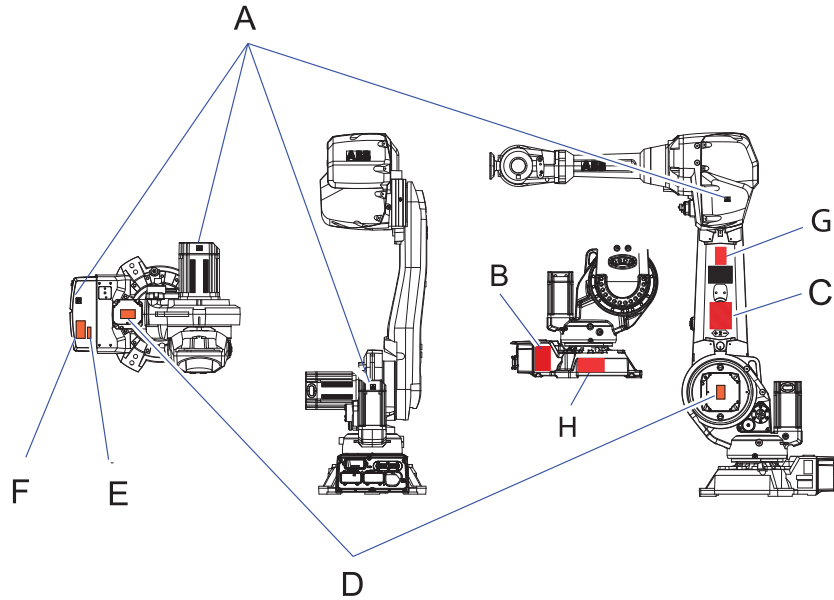

xx100000197

A	Warning - Symbol of flash (4 pcs)
B	Warning - Risk of tipping
C	Label - Lifting instruction
D	Warning - "High temperature" (2 pcs)
E	Label - Max. air pressure
F	Warning - Brake release unit
G	Label - Calibration
H	Label - Suspended robot

##### Required equipment

Equipment	Spare part number	Note
Labels	See <a href="#">Spare part lists on page 403</a> .	

*Continues on next page*

#### Inspecting labels

Use this procedure to inspect the labels on the robot.

	Action	Note
1	 <b>DANGER</b> Turn off all: <ul style="list-style-type: none"> <li>• electric power supply</li> <li>• hydraulic pressure supply</li> </ul> to the robot, before entering the robot working area.	
2	Check all labels.	See the figure in <a href="#">Location of information labels on page 134</a> .
3	Replace any missing or damaged labels.	

### 3 Maintenance

#### 3.4.8 Inspecting the mechanical stop pin, axis 1

#### 3.4.8 Inspecting the mechanical stop pin, axis 1

##### Location of mechanical stop pin, axis 1

The mechanical stop pin is located on the frame as shown in the figure.

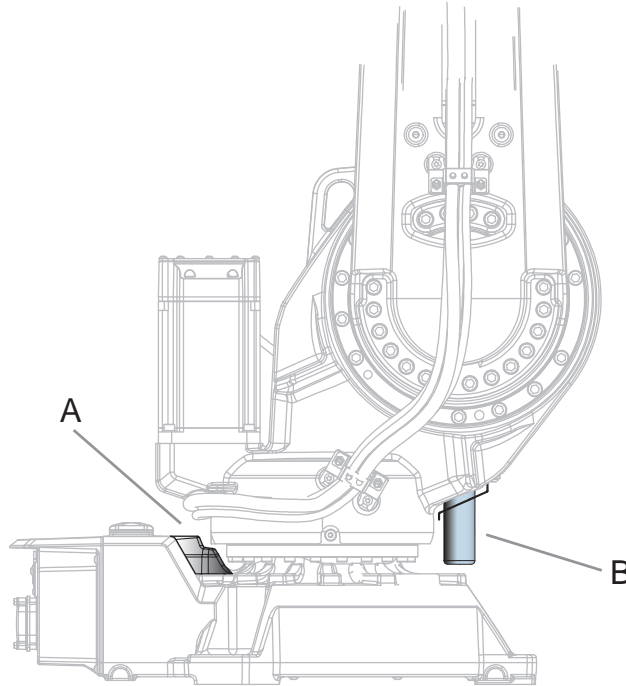

xx080000298

A	Fixed stop
B	Mechanical stop pin, axis 1

##### Required equipment

Equipment	Article number	Note
Mechanical stop pin axis 1	See <a href="#">Spare part lists on page 403</a> .	
Standard toolkit		Content is defined in section <a href="#">Standard tools on page 398</a> .
Other tools and procedures may be required. See references to these procedures in the step-by-step instructions below.		These procedures include references to the tools required.

##### Additional equipment - Foundry Prime



Equipment	Article number	Note
Rust preventive	3HAC034903-001	Mercasol
Sikaflex 521FC	3HAC026759-001	
Loctite 574	12340011-116	
Brush		

*Continues on next page*

Equipment	Article number	Note
Foundry Prime touch up kit	3HAC035355-001	

#### Inspection of mechanical stop pin, axis 1

Use this procedure to inspect the mechanical stop pin, axis 1.

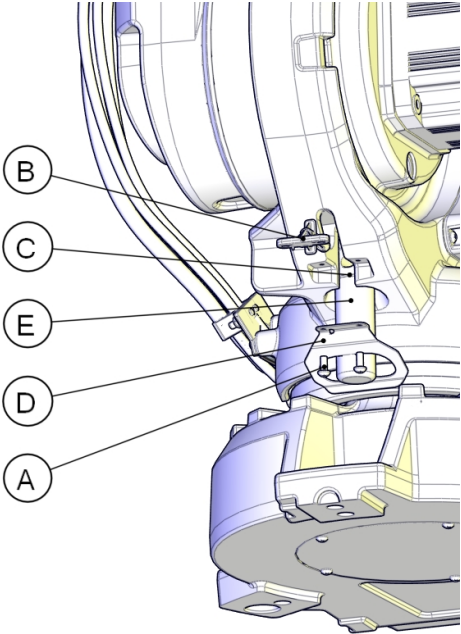
Action	Note
<p>1</p>  <p><b>DANGER</b></p> <p>Turn off all:</p> <ul style="list-style-type: none"> <li>• electric power supply</li> <li>• hydraulic pressure supply</li> </ul> <p>to the robot, before entering the robot working area.</p>	
<p>2</p> <p>Regularly check that the <i>mechanical stop pin</i> is not bent or damaged in any other way.</p>	<p>See the figure in:</p> <ul style="list-style-type: none"> <li>• <a href="#">Location of mechanical stop pin, axis 1 on page 136</a></li> </ul>
<p>3</p>  <p><b>Note</b></p> <p>If the mechanical stop pin has been deformed or damaged, all of its mounting parts have to be replaced.</p>  <p>xx0800000045</p> <p><b>Parts:</b></p> <ul style="list-style-type: none"> <li>A Attachment screws</li> <li>B Bracket</li> <li>C O-ring (2 pcs) - Not used if bracket (D) is installed.</li> <li>D Bracket</li> <li>E Stop pin</li> </ul>	<p>How to replace the stop pin is described in section <a href="#">Replacing stop pin axis 1 on page 300</a>.</p>

Continues on next page

### 3 Maintenance

#### 3.4.8 Inspecting the mechanical stop pin, axis 1

*Continued*

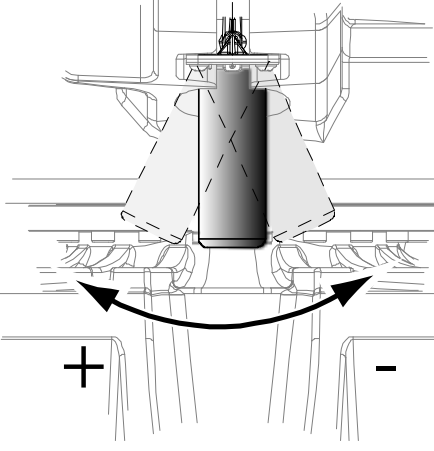
	Action	Note
4	Check that the mechanical stop pin is properly attached.	
5	Check that the <i>mechanical stop pin</i> can move freely in both directions and the <i>bracket</i> works as it is supposed to.	 <p data-bbox="965 846 1066 869">xx100000222</p>
6	Seal and paint the joints that have been opened. Also repair possible damages of the special Foundry Prime paint coat of the robot. See <a href="#">Cut the paint or surface on the robot before replacing parts on page 200</a> .	

### 3.4.9 Inspecting additional mechanical stops

#### Location of additional mechanical stops

The figure shows the location of the additional stops.

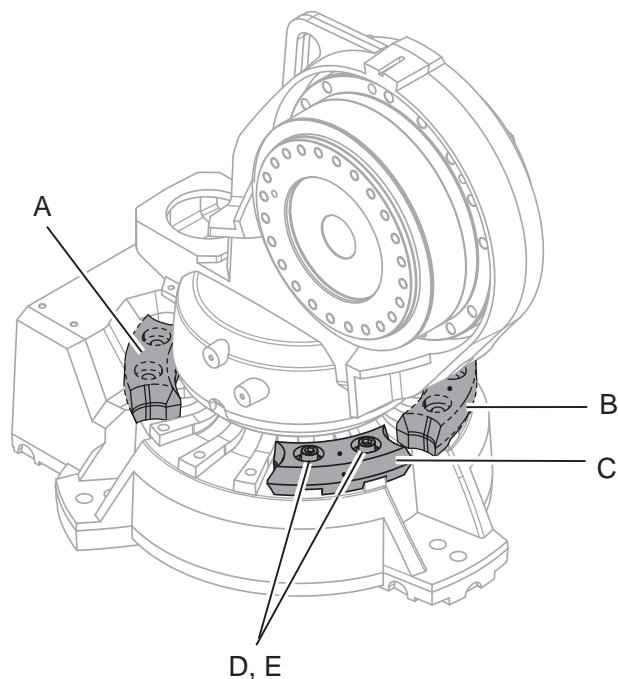

xx0800000273

A	Movable mechanical stop. Limited to: <ul style="list-style-type: none"> <li>-129°</li> </ul>
B	Movable mechanical stop. Limited to: <ul style="list-style-type: none"> <li>+16.5°</li> </ul>
C	Movable mechanical stop. Limited to: <ul style="list-style-type: none"> <li>-16.5°</li> </ul>
D	Attachment screws
E	Washers

#### Required equipment

Equipment etc.	Note
Mechanical stop set, axis 1	Includes: <ul style="list-style-type: none"> <li>Stop</li> <li>Attachment screws plus washers</li> <li>Document for movable mechanical stop</li> </ul> For spare part number see <a href="#">Spare part lists on page 403</a> .
Standard toolkit	Content is defined in section <a href="#">Standard tools on page 398</a> .
Other tools and procedures may be required. See references to these procedures in the step-by-step instructions below.	These procedures include references to the tools required.

Continues on next page

## 3 Maintenance

### 3.4.9 Inspecting additional mechanical stops

*Continued*

#### Additional equipment - Foundry Prime

Equipment	Art. no.	Note
Rust preventive	3HAC034903-001	Mercasol
Sikaflex 521FC	3HAC026759-001	
Loctite 574	12340011-116	
Brush		
Foundry Prime touch up kit	3HAC035355-001	

#### Inspecting additional mechanical stops

Use this procedure to inspect the additional mechanical stops on axis 1.

	Action	Note
1	 <b>DANGER</b> Turn off all: <ul style="list-style-type: none"><li>• electric power supply</li><li>• hydraulic pressure supply</li></ul> to the robot, before entering the robot working area.	
2	Check the <i>additional mechanical stops</i> on axis 1 for damage.	See the figure in: <ul style="list-style-type: none"><li>• <a href="#">Location of additional mechanical stops on page 139</a></li></ul>
3	Make sure the stops are properly attached.	Tightening torque: <ul style="list-style-type: none"><li>• 82 Nm</li></ul>
4	If any damage on stops or attachment screws etc. is detected, the <i>mechanical stops</i> must be replaced!	Attachment screws: <ul style="list-style-type: none"><li>• M12x40, quality 8.8-A3F</li><li>• 2 pcs/stop lug</li></ul>
5	seal and paint the joints that have been opened. Also repair possible damages of the special Foundry Prime paint coat of the robot. See <a href="#">Cut the paint or surface on the robot before replacing parts on page 200</a> .	



### 3.4.10 Inspecting dampers

#### Location of dampers

The figure shows the location of all dampers to be inspected.

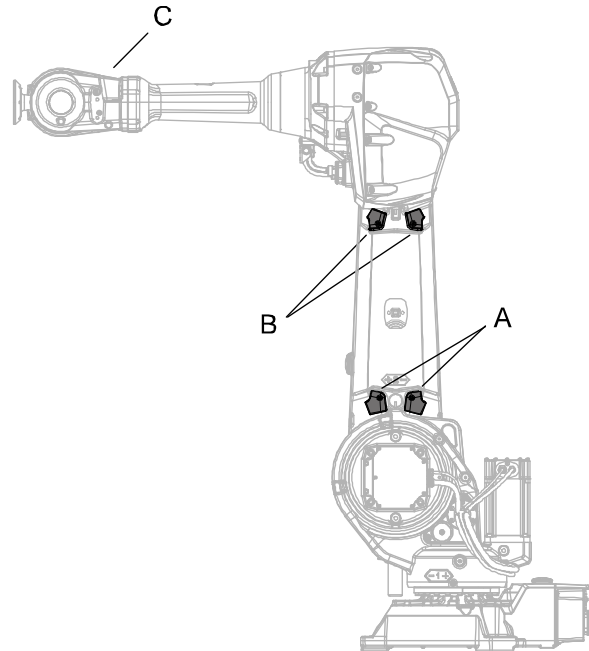

xx080000297

A	Dampers axis 2
B	Dampers axis 3
C	Damper axis 5

#### Required equipment

Equipment	Spare part no.	Note
Damper	See <a href="#">Spare part lists on page 403</a> .	
Standard toolkit	-	Content is defined in section <a href="#">Standard tools on page 398</a> .

#### Additional equipment - Foundry Prime

Equipment	Art. no.	Note
Rust preventive	3HAC034903-001	Mercasol
Sikaflex 521FC	3HAC026759-001	
Loctite 574	12340011-116	
Brush		
Foundry Prime touch up kit	3HAC035355-001	

*Continues on next page*

## 3 Maintenance

### 3.4.10 Inspecting dampers

*Continued*

#### Inspecting dampers

Use this procedure to inspect the dampers.

	Action	Note
1	 <b>DANGER</b>  Turn off all: <ul style="list-style-type: none"><li>• electric power supply</li><li>• hydraulic pressure supply</li></ul> to the robot, before entering the robot working area.	
2	Check all <i>dampers</i> for damage or cracks.	See the figure in: <ul style="list-style-type: none"><li>• <a href="#">Location of dampers on page 141</a></li></ul>
3	Check all dampers for existing impressions larger than 2-3 mm.	
4	Check attachment screws for deformation.	
5	If any damage is detected the damper must be replaced.	
6	Seal and paint the joints that have been opened. Also repair possible damages of the special Foundry Prime paint coat of the robot. See <a href="#">Cut the paint or surface on the robot before replacing parts on page 200</a> .	

3.4.11 Inspecting the leak proof o-ring and pressure relief valves

Location of the leak proof o-ring

The pressure relief valves and leak proof o-ring is located as shown in the figure.

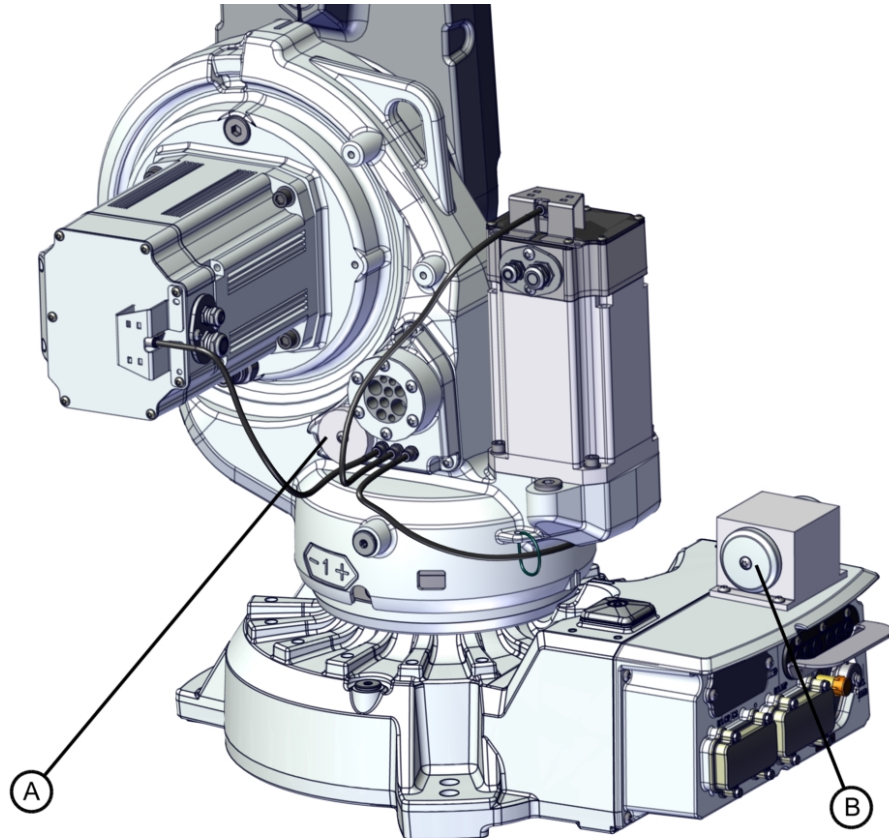

A	Leak proof o-ring
B	Relief valve (2 pcs)

Required tools and equipment

Equipment	Article number	Note
Standard toolkit		Content is defined in section <a href="#">Standard tools on page 398</a> .
Brush		
Foundry Prime touch up kit	3HAC035355-001	
Leak spray		

Required consumables

Consumable	Article number	Note
Rust preventive	3HAC034903-001	Mercasol
Sikaflex 521FC	3HAC026759-001	
Loctite 574	12340011-116	

Continues on next page





### 3 Maintenance

#### 3.4.11 Inspecting the leak proof o-ring and pressure relief valves

*Continued*

#### Inspecting the leak proof o-ring and pressure relief valves

Use this procedure to inspect the leak proof o-ring and pressure relief valves.

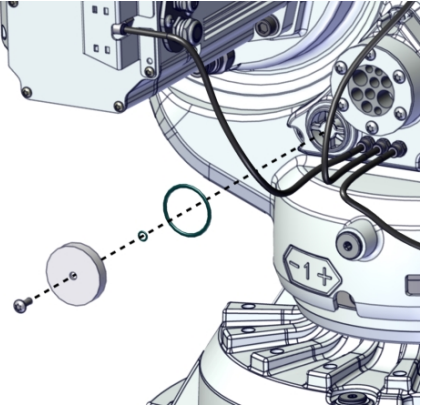
	Action	Note
1	<p> <b>DANGER</b></p> <p>Turn off all:</p> <ul style="list-style-type: none"> <li>• electric power supply</li> <li>• hydraulic pressure supply</li> </ul> <p>to the robot, before entering the robot working area.</p>	
2	<p> <b>DANGER</b></p> <p>It is important to keep the pressure relief valve open and clean. If the air pressure is stopped up, too much pressure can be built up which can be hazardous.</p>	
3	<p>Check if the leak proof o-ring is contaminated or covered with litter.</p> <p>Clean if necessary.</p> <p> <b>Note</b></p> <p>Use a cloth or a brush.</p>	
4	<p>Spray the leak proof o-ring valve with leak spray.</p> <ul style="list-style-type: none"> <li>• If leak is found, change the 41 mm o-ring, according to figure.</li> </ul> <p> <b>Note</b></p> <p>Make sure not to lose the small o-ring.</p>	 <p>xx1700001174</p> <ul style="list-style-type: none"> <li>• Screw</li> <li>• Cover</li> <li>• O-ring 6.1 mm</li> <li>• O-ring 41 mm</li> </ul>

*Continues on next page*

#### 3.4.11 Inspecting the leak proof o-ring and pressure relief valves

*Continued*

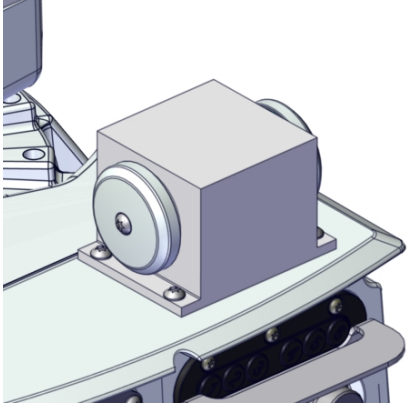
Action	Note
<p>5 Check if the pressure relief valves are contaminated or covered with litter. Clean if necessary.</p> <p> <b>Note</b> Use a cloth or a brush.</p>	 <p>xx1700001178</p>
<p>6 Seal and paint the joints that have been opened. Also repair possible damages of the special Foundry Prime paint coat of the robot. See <a href="#">Cut the paint or surface on the robot before replacing parts on page 200</a>.</p>	

### 3 Maintenance

#### 3.4.12 Inspecting Signal lamp (option)

#### 3.4.12 Inspecting Signal lamp (option)

##### Location of signal lamp

Signal lamp is an option.

Located as shown in the figure.

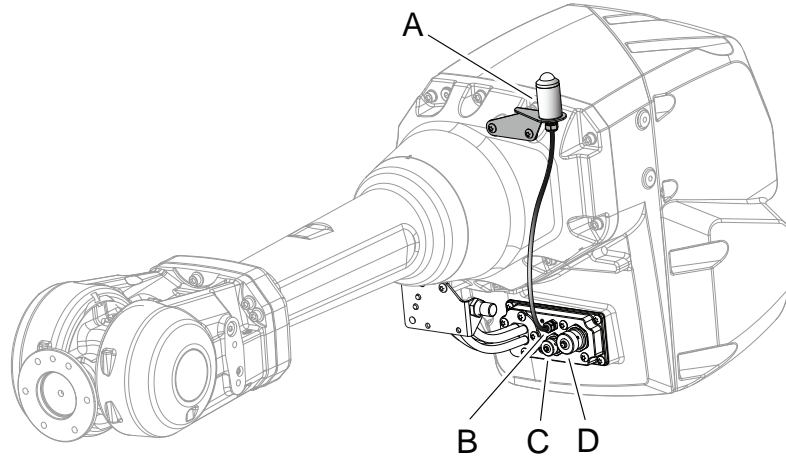

xx0800000290

A	Signal lamp
B	R3.H1 +, R3.H2 -
C	R2.CP
D	R2.CS

##### Required equipment

Equipment	Note
Signal lamp	For spare parts no. see Spare parts - Spare parts options in Product manual, spare parts - IRB 2600.
Standard toolkit	Content is defined in section <a href="#">Standard tools on page 398</a> .
Other tools and procedures may be required. See references to these procedures in the step-by-step instructions below.	These procedures include references to the tools required.

##### Additional equipment - Foundry Prime

Equipment	Art. no.	Note
Rust preventive	3HAC034903-001	Mercasol
Sikaflex 521FC	3HAC026759-001	
Loctite 574	12340011-116	
Brush		
Foundry Prime touch up kit	3HAC035355-001	

Continues on next page

**CAUTION**

Always cut the paint with a knife and grind the paint edge when disassembling parts. See [Cut the paint or surface on the robot before replacing parts on page 200](#).

**Inspecting signal lamp**

Use this procedure to inspect the function of the signal lamp.

**Note**

If the signal lamp is damaged, it shall be replaced!

	Action	Note
1	Check that the signal lamp is lit when motors are put in operation ("MOTORS ON").	
2	If the signal lamp is not lit, continue tracing the fault with the steps below.	
3	 <b>DANGER</b> Turn off all: <ul style="list-style-type: none"> <li>• electric power supply</li> <li>• hydraulic pressure supply</li> </ul> to the robot, before entering the robot working area.	
4	Check whether the signal lamp is broken. If so, replace.	
5	Check the cable connections.	
6	Measure the voltage in connectors, motor axis 3.	24V
7	Check the cabling. If a fault is detected, replace.	
8	Seal and paint the joints that have been opened. Also repair possible damages of the special Foundry Prime paint coat of the robot. See <a href="#">Cut the paint or surface on the robot before replacing parts on page 200</a> .	

### 3 Maintenance

#### 3.4.13 Inspection of air hoses (Foundry Prime)

#### 3.4.13 Inspection of air hoses (Foundry Prime)

##### General

The air hoses on Foundry Prime robots must be inspected for leakage every six months.

##### Required equipment

Equipment, etc.	Art. no.
Leak detection spray	-
Pressure gauge	-
Cut off valve	-

##### Procedure

For this test it is recommended that the air supply to the robot has a pressure gauge and a cut-off valve connected.

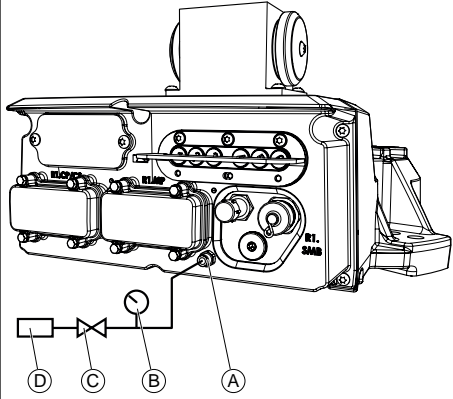
Action	Note
1 Apply compressed air to the air connector on robot base, and raise the pressure with the knob until the correct value is shown on the pressure gauge.	<p>Recommended pressure: 0.2-0.3 bar</p>  <p>xx1500002399</p> <ul style="list-style-type: none"> <li>A: Air connection robot</li> <li>B: Pressure gauge</li> <li>C: Cut off valve</li> <li>D: Air connection</li> </ul>
2 Close the cut off valve.	It should take at least 5 seconds for the pressure to reach 0 bar.
3 The time is < 5 seconds: <ul style="list-style-type: none"> <li>If the answer is YES: Localize the leakage by following the procedures below.</li> <li>If the answer is NO: The system is OK. Remove the leak testing equipment.</li> </ul>	
4 Pressurize by opening the cut off valve.	

Continues on next page



	Action	Note
5	<p>Spray suspected leak areas with leak detection spray.</p> <p> <b>Note</b> Bubbles indicate a leak.</p>	
6	<p>When the leak is localized: correct the leak.</p>	

### 3 Maintenance

---

#### 3.4.14 Inspection of surface treatment (Foundry Prime)

#### 3.4.14 Inspection of surface treatment (Foundry Prime)

---

##### Introduction to inspection of surface treatment

Damage to painted surfaces must be repaired as soon as possible to avoid corrosion. All painted surfaces on the robot must be inspected.

---

##### Required equipment

Equipment, etc.	Note
Touch up paint Foundry Prime 2, grey	

---

##### Additional equipment - Foundry Prime

Equipment	Article number	Note
Rust preventive	3HAC034903-001	Mercasol. Recommended drying time is 24h.
Sikaflex 521FC	3HAC026759-001	
Loctite 574	12340011-116	
Brush		
Foundry Prime touch up kit	3HAC035355-001	

---

##### Inspection and repair of surface treatment

Use this procedure to inspect the surface treatment on Foundry Prime robots.

	Action	Information
1	Inspect all painted surfaces for damage.	
2	Repair any damage as described in the instruction included in the spare part kit.	

## 3.5 Replacement activities

### 3.5.1 Type of lubrication in gearboxes

#### Introduction

This section describes where to find information about the type of lubrication, article number and the amount of lubrication in the specific gearbox. It also describes the equipment needed when working with lubrication.

#### Type and amount of oil in gearboxes

Information about the type of lubrication, article number as well as the amount in the specific gearbox can be found in *Technical reference manual - Lubrication in gearboxes* available for registered users on myABB Business Portal, [www.abb.com/myABB](http://www.abb.com/myABB).



#### Note

The type of oil pre-filled in axis-4 gear differs from the type of oil recommended for field maintenance, due to differences in factory and customer sites prerequisites. The two types of oil are fully equal and compatible.

Use the type of oil specified in *Technical reference manual - Lubrication in gearboxes*, even though it differs from the oil specified in WebConfig.

#### Location of gearboxes

The figure shows the location of the gearboxes.

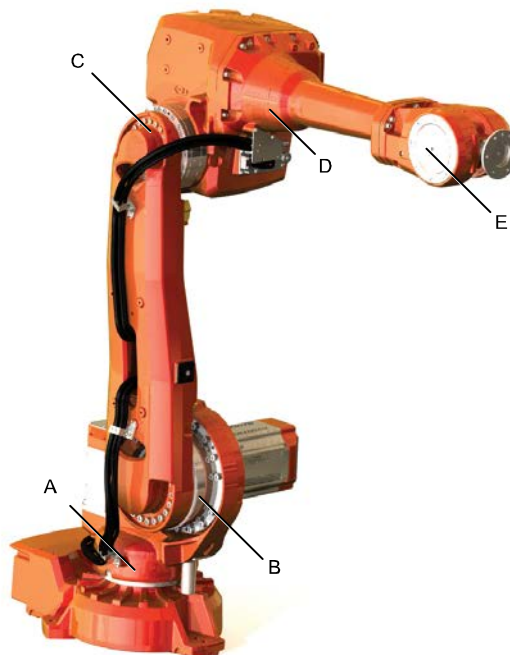

xx080000311

*Continues on next page*

### 3 Maintenance

---

#### 3.5.1 Type of lubrication in gearboxes

*Continued*

A	Axis-1 gearbox
B	Axis-2 gearbox
C	Axis-3 gearbox
D	Axis-4 gearbox
E	Axis-5 and -6 gearbox

---

#### Equipment

Equipment	Note
Oil dispenser	Includes pump with outlet pipe. Use the suggested dispenser or a similar one: <ul style="list-style-type: none"><li>• Orion OriCan article number 22590 (pneumatic)</li></ul>
Nipple for quick connect fitting, with o-ring	Used on the axis-2 gearbox.
Expansion container, gearbox axis 1	Used when the robot is fitted in a suspended position. (valid for other design than Type C and Type D)

3.5.2 Changing the oil, axis 1 gearbox on floor mounted robots

General

This section describes how to change the axis-1 gearbox oil in a floor mounted robot.

Location of oil plugs

The oil plugs are located according to following figures.

Type A:

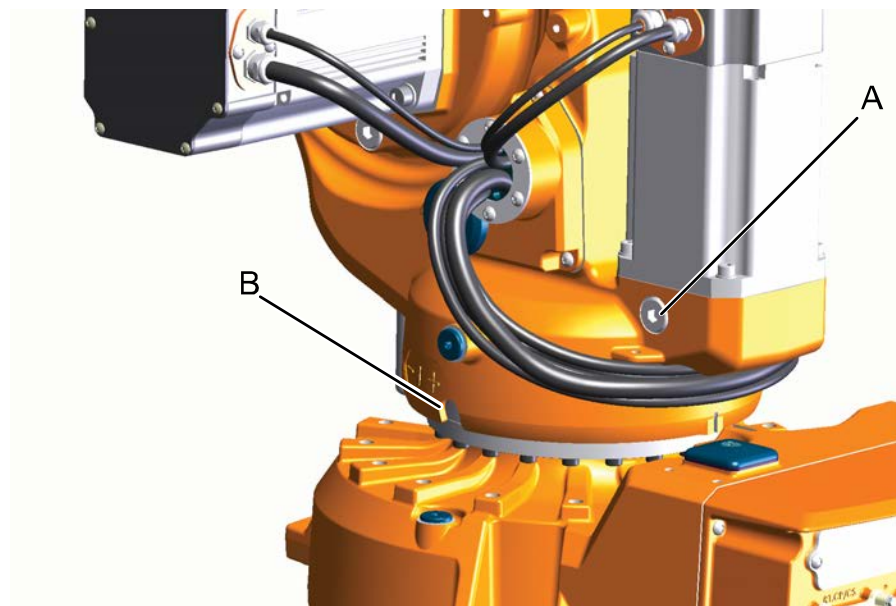

xx080000304

A	Oil plug, filling and venting
B	Oil plug, draining

*Continues on next page*

### 3 Maintenance

#### 3.5.2 Changing the oil, axis 1 gearbox on floor mounted robots

Continued

Type B:

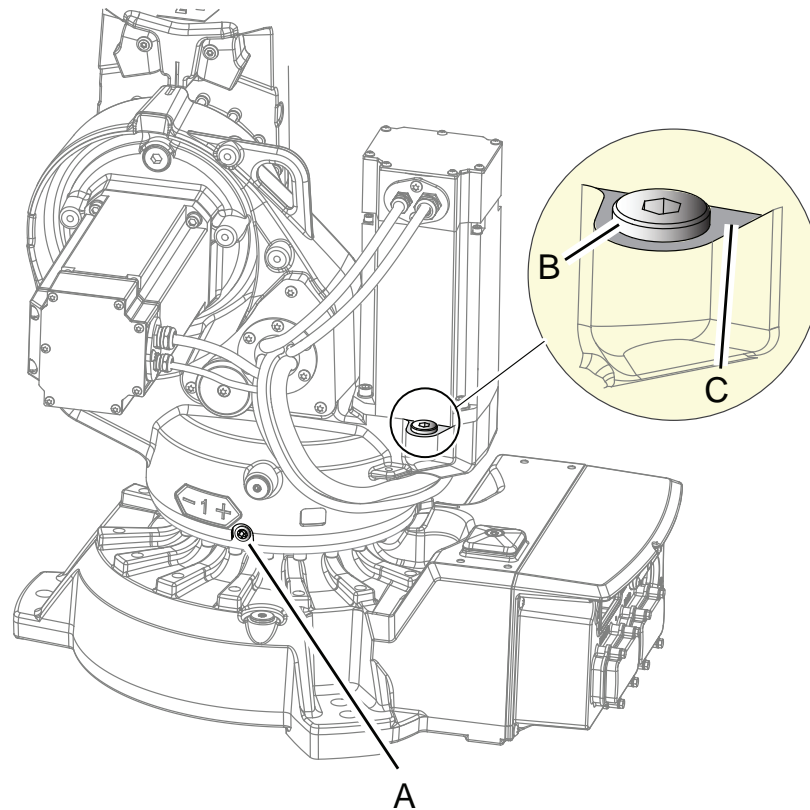

xx100000669

A	Oil draining plug gearbox 1
B	Oil filling and venting plug for gearbox 1
C	Surface for motor flange

#### Required equipment

Equipment	Note
Oil plug sealing washer, gearbox	3HAC029646-001
Lubricating oil	See section <a href="#">Type of lubrication in gearboxes on page 151</a> .
Oil collecting vessel	The capacity of the vessel must be sufficient to take the complete amount of oil.
Oil dispenser	One example of oil dispenser can be found in section: <ul style="list-style-type: none"> <li><a href="#">Type of lubrication in gearboxes on page 151</a></li> </ul>
Standard toolkit	Content is defined in section <a href="#">Standard tools on page 398</a> .

#### Additional equipment - Foundry Prime

Equipment	Art. no.	Note
Rust preventive	3HAC034903-001	Mercasol

Continues on next page

Equipment	Art. no.	Note
Sikaflex 521FC	3HAC026759-001	
Loctite 574	12340011-116	
Brush		
Foundry Prime touch up kit	3HAC035355-001	





#### CAUTION

Always cut the paint with a knife and grind the paint edge when disassembling parts. See [Cut the paint or surface on the robot before replacing parts on page 200](#).

#### Draining, axis 1 gearbox

Use this procedure to drain the gearbox of oil.

The oil must be sucked out from the gearbox. It is recommended to use a pneumatic oil dispenser to drain oil from the gearbox.





	Action	Note
1	 <b>DANGER</b> Turn off all: <ul style="list-style-type: none"> <li>• electric power supply</li> <li>• hydraulic pressure supply</li> </ul> to the robot, before entering the robot working area.	
2	 <b>WARNING</b> Handling gearbox oil involves several safety risks, see <a href="#">Gearbox lubricants (oil or grease) on page 34</a> .	
3	 <b>CAUTION</b> The gearbox can contain an <i>excess of pressure</i> that can be hazardous. Open the oil plug carefully in order to let out the excess pressure.	

*Continues on next page*

### 3 Maintenance

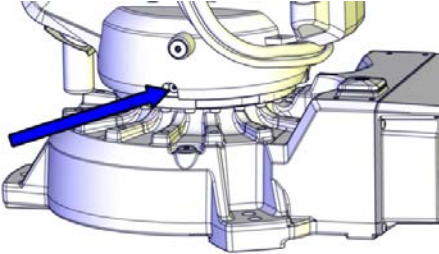

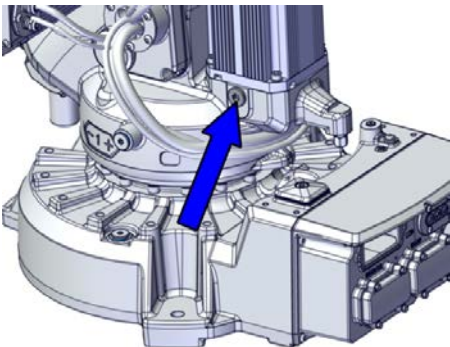
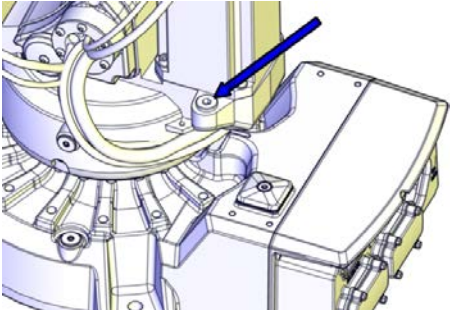
#### 3.5.2 Changing the oil, axis 1 gearbox on floor mounted robots

Continued

	Action	Note
4	<ul style="list-style-type: none"> <li>• Put an <i>oil collecting vessel</i> as close as possible to the draining hole of the gearbox.</li> <li>• Replace <i>oil plug draining</i> quickly with a nipple (M10x1.5) where a draining hose is fitted and connect the <i>oil dispenser</i>.</li> </ul>	<p>The capacity of the vessel must be sufficient to take the complete amount of oil.</p>  <p>xx1800001138</p> <p> <b>Note</b></p> <p>Draining is time-consuming. Elapsed time varies depending on the temperature of the oil.</p> <p>One example of oil dispenser can be found in section:</p> <ul style="list-style-type: none"> <li>• <a href="#">Type of lubrication in gearboxes on page 151</a></li> </ul>
5	<p>Remove the plug from the vent hole.</p> <p> <b>WARNING</b></p> <p>If the oil plug for venting is not open when the oil dispenser is working, there is a risk of damaging vital parts in the gearbox!</p>	<p>Different position due to design differences:</p>  <p>xx1800001137</p>  <p>xx1800001139</p>
6	<p>Suck out the oil with the oil dispenser.</p> <p> <b>Note</b></p> <p>There will be some oil left in the gear after draining.</p>	

Continues on next page

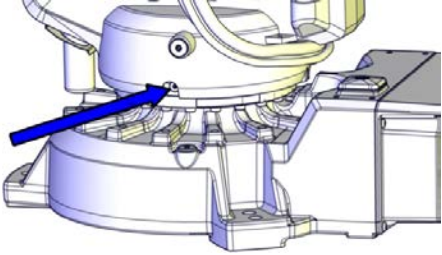
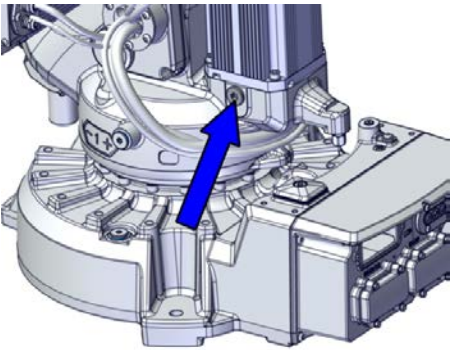
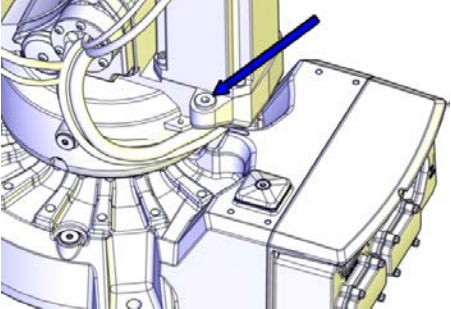

	Action	Note
7	 <b>WARNING</b> Used oil is hazardous material and must be disposed of in a safe way. See section <a href="#">Decommissioning on page 387</a> for more information.	
8	Remove the oil dispenser.	
9	Refit the <i>oil plug, draining</i> .   <b>Note</b> Before refitting the oil plug in the gearbox, always replace the oil plug gasket with a new gasket. If not there is a risk of leakage.	Tightening torque:   xx1800001138
10	Refit the <i>oil plug, venting</i> .	Tightening torque: 24 Nm Different position due to design differences:   xx1800001137    xx1800001139
11	If the robots paint coat is damaged during the procedure, paint touchup is needed.	See <a href="#">Inspection and repair of surface treatment on page 150</a>

*Continues on next page*



### 3 Maintenance

#### 3.5.2 Changing the oil, axis 1 gearbox on floor mounted robots

*Continued*

#### Filling oil, axis 1 gearbox

Use this procedure to fill the gearbox with oil.

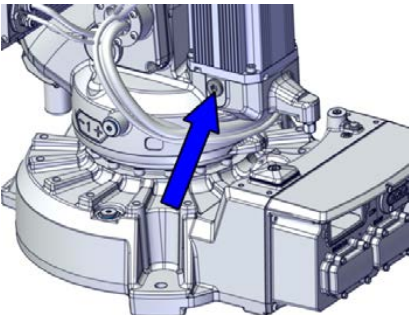
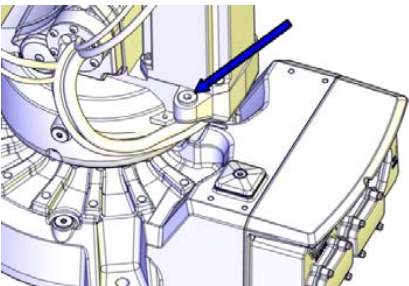
	Action	Note
1	<p> <b>DANGER</b></p> <p>Turn off all:</p> <ul style="list-style-type: none"> <li>• electric power supply</li> <li>• hydraulic pressure supply</li> </ul> <p>to the robot, before entering the robot working area.</p>	
2	<p> <b>WARNING</b></p> <p>Handling gearbox oil involves several safety risks, see <a href="#">Gearbox lubricants (oil or grease) on page 34</a>.</p>	
3	<p> <b>CAUTION</b></p> <p>The gearbox can contain an <i>excess of pressure</i> that can be hazardous. Open the oil plug carefully in order to let out the excess pressure.</p>	
4	<p>Open the <i>oil plug, filling</i>.</p>	<p>Different position due to design differences:</p>  <p>xx1800001137</p>  <p>xx1800001139</p>

*Continues on next page*

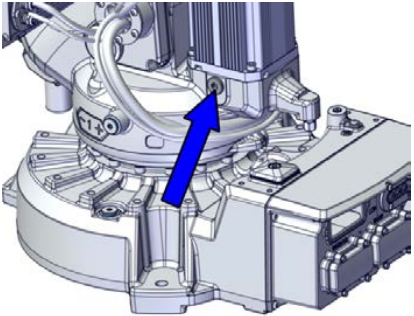
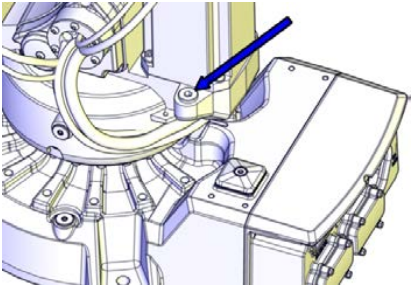
	Action	Note
5	Refill the gearbox with <i>lubrication oil</i> .  <b>Note</b> The amount of oil to be filled depends on the amount previously being drained.	Where to find type of oil and total amount is detailed in <a href="#">Type and amount of oil in gearboxes on page 151</a> .
6	Inspect the oil level.	How to inspect the oil level is described in section: <ul style="list-style-type: none"> <li>• <a href="#">Inspecting oil level, axis 1 gearbox on page 115</a></li> </ul>
7	Refit the <i>oil plug</i> .	Tightening torque: 24 Nm Different position due to design differences:  <small>xx1800001137</small>  <small>xx1800001139</small>
8	Seal and paint the joints that have been opened. Also repair possible damages of the special Foundry Prime paint coat of the robot. See <a href="#">Cut the paint or surface on the robot before replacing parts on page 200</a> .	

## 3 Maintenance

### 3.5.3 Changing the oil, axis-1 gearbox on suspended robots

### 3.5.3 Changing the oil, axis-1 gearbox on suspended robots

#### General

This section describes how to change the axis-1 gearbox oil in a suspended robot.

#### Location of oil plugs

The oil plugs in axis 1 gearbox are located according to the following figures

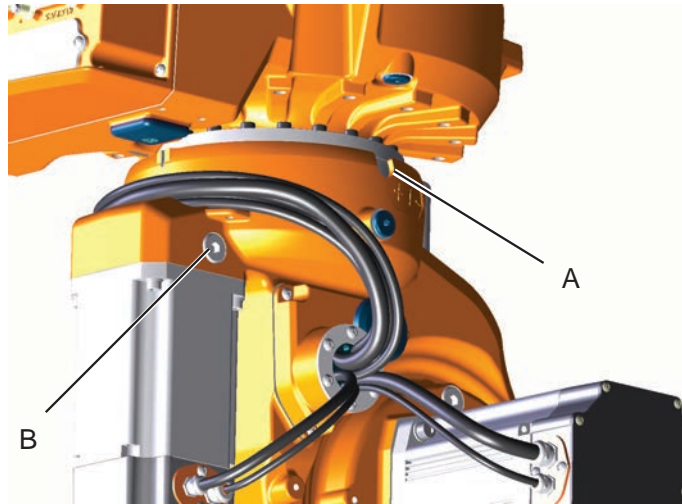

xx1200000883

A	Oil plug, venting
B	Oil plug, draining and filling

#### Required equipment

Equipment	Note
Oil plug sealing washer, gearbox	3HAC029646-001
Lubricating oil	See section <a href="#">Type of lubrication in gearboxes on page 151</a>
Oil collecting vessel	The capacity of the vessel must be sufficient to take the complete amount of oil.
Oil dispenser	One example of oil dispenser can be found in section: <ul style="list-style-type: none"><li>• <a href="#">Type of lubrication in gearboxes on page 151</a></li></ul>
Oil change equipment	
Hose	Used with the oil dispenser
Standard toolkit	Content is defined in section <a href="#">Standard tools on page 398</a> .

#### Additional equipment - Foundry Prime

Equipment	Art. no.	Note
Rust preventive	3HAC034903-001	Mercasol

*Continues on next page*

Equipment	Art. no.	Note
Sikaflex 521FC	3HAC026759-001	
Loctite 574	12340011-116	
Brush		
Foundry Prime touch up kit	3HAC035355-001	



#### CAUTION

Always cut the paint with a knife and grind the paint edge when disassembling parts. See [Cut the paint or surface on the robot before replacing parts on page 200](#).

#### Draining, axis-1 gearbox

Use this procedure to drain the gearbox of oil.



#### Tip

In order to save time, a pneumatic oil dispenser can be used to suck the oil out from the gearbox.





	Action	Note
1	<b>DANGER</b> Turn off all: <ul style="list-style-type: none"> <li>• electric power supply</li> <li>• hydraulic pressure supply</li> </ul> to the robot, before entering the robot working area.	
2	<b>WARNING</b> Handling gearbox oil involves several safety risks, see <a href="#">Gearbox lubricants (oil or grease) on page 34</a> .	
3	<b>CAUTION</b> The gearbox can contain an <i>excess of pressure</i> that can be hazardous. Open the oil plug carefully in order to let out the excess pressure.	

*Continues on next page*

### 3 Maintenance

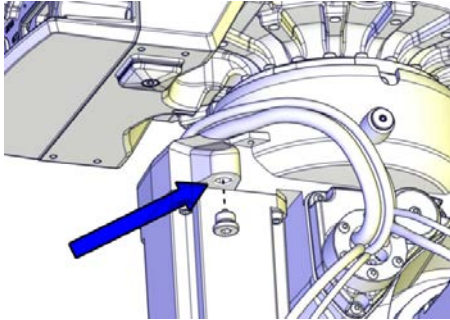
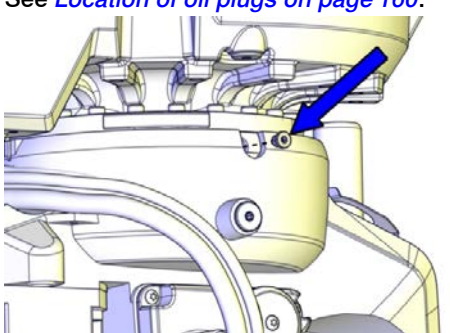
#### 3.5.3 Changing the oil, axis-1 gearbox on suspended robots





Continued

	Action	Note
4	Connect the <i>oil dispenser</i> to the <i>oil plug for draining</i> .	See <a href="#">Required equipment on page 160</a> .  xx1800001271
5	Put the end of the hose in an <i>oil collecting vessel</i> .	The capacity of the vessel must be sufficient to take the complete amount of oil.
6	Open the end plug of the hose.	
7	Open the <i>oil plug, venting</i> .	See <a href="#">Location of oil plugs on page 160</a> .  xx1800001272
8	Using a low air pressure, start sucking the oil out from the gearbox with the oil change equipment.	
9	 <b>WARNING</b> Used oil is hazardous material and must be disposed of in a safe way. See section <a href="#">Decommissioning on page 387</a> for more information.	
10	Let the oil drain until the gearbox is empty.  <b>Note</b> There will be some oil left in the gearbox after draining. Measure the volume of the drained oil in the vessel.	 <b>Tip</b> Make a note how much oil was drained. The same amount shall later be refilled.
11	Remove the hose and clean it.	
12	If the robots paint coat is damaged during the procedure, paint touch-up is needed.	See <a href="#">Inspection and repair of surface treatment on page 150</a>

Continues on next page

Filling oil, axis-1 gearbox

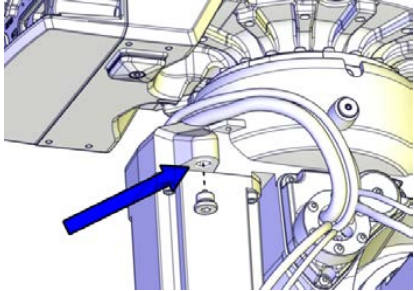
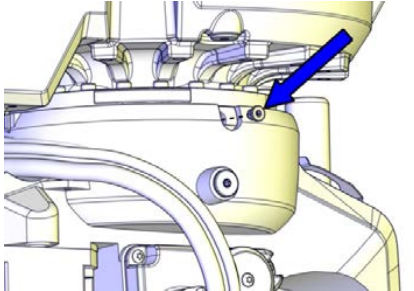
Use this procedure to fill the gearbox with oil.

	Action	Note
1	 <b>DANGER</b> Turn off all: <ul style="list-style-type: none"> <li>• electric power supply</li> <li>• hydraulic pressure supply</li> </ul> to the robot, before entering the robot working area.	
2	 <b>WARNING</b> Handling gearbox oil involves several safety risks, see <a href="#">Gearbox lubricants (oil or grease) on page 34</a> .	
3	 <b>CAUTION</b> The gearbox can contain an <i>excess of pressure</i> that can be hazardous. Open the oil plug carefully in order to let out the excess pressure.	
4	Verify that the hose of the oil change equipment is clean and then fit the quick connection to the <i>oil plug for filling</i> .	 xx1800001271
5	Open the oil <i>plug for venting</i> .	 xx1800001272
6	Prepare oil change equipment with the same amount of <i>lubrication oil</i> that was drained.   <b>Note</b> The amount of oil to be filled depends on the amount previously being drained.	Where to find type of oil and total amount is detailed in <a href="#">Type and amount of oil in gearboxes on page 151</a> .

Continues on next page



### 3 Maintenance

#### 3.5.3 Changing the oil, axis-1 gearbox on suspended robots

Continued

	Action	Note
7	Inspect the oil level.	How to inspect the oil level is described in section: <ul style="list-style-type: none"> <li>• <a href="#">Inspecting oil level, axis 1 gearbox on page 115</a></li> </ul>
8	Disconnect the oil change equipment and put on the protective hood on the oil plug.	
9	Refit the <i>oil plug for venting</i> .   <b>Note</b> Before refitting the oil plug in the gearbox, always replace the oil plug sealing washer with a new one. If not there is a risk of leakage.	Tightening torque: <ul style="list-style-type: none"> <li>• 3-8 Nm</li> </ul>
10	Seal and paint the joints that have been opened. Also repair possible damages of the special Foundry Prime paint coat of the robot. See <a href="#">Cut the paint or surface on the robot before replacing parts on page 200</a> .	

#### Expansion container axis-1 gearbox, suspended mounted robots

When the robot is fitted in a suspended mounted position, an expansion container for oil must be fitted on gearbox axis 1.

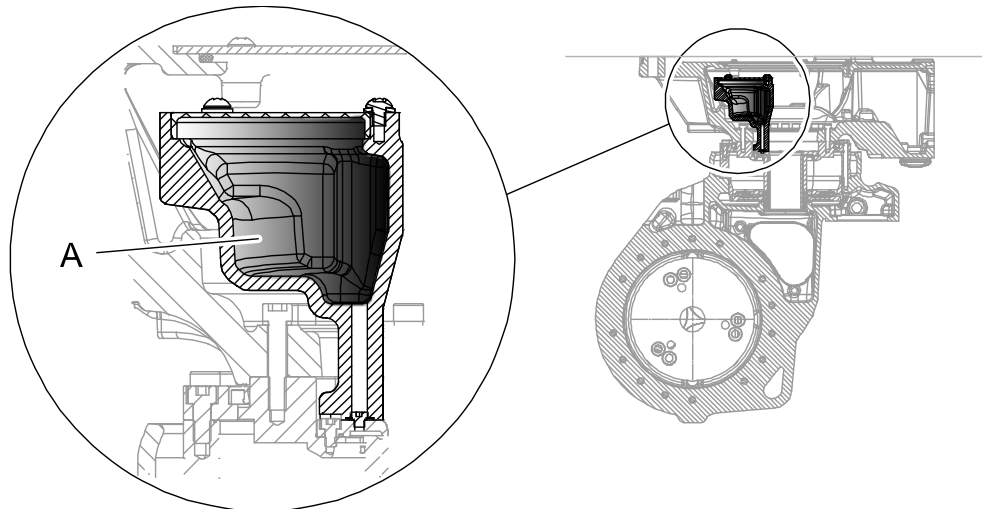

xx0900000129

A	Expansion container
---	---------------------



#### Note

The expansion container is installed on delivery on the robot if ordered as option suspended/inverted mounted. If a floor mounted robot shall be fitted in a suspended mounted position, an expansion container must be installed. See [Installing an expansion container on page 86](#).



### 3.5.4 Changing the oil, axis-2 gearbox

#### Location of oil plugs

The axis-2 gearbox is located in the lower arm rotational center, underneath the motor attachment.

Oil plugs are shown in the figure.

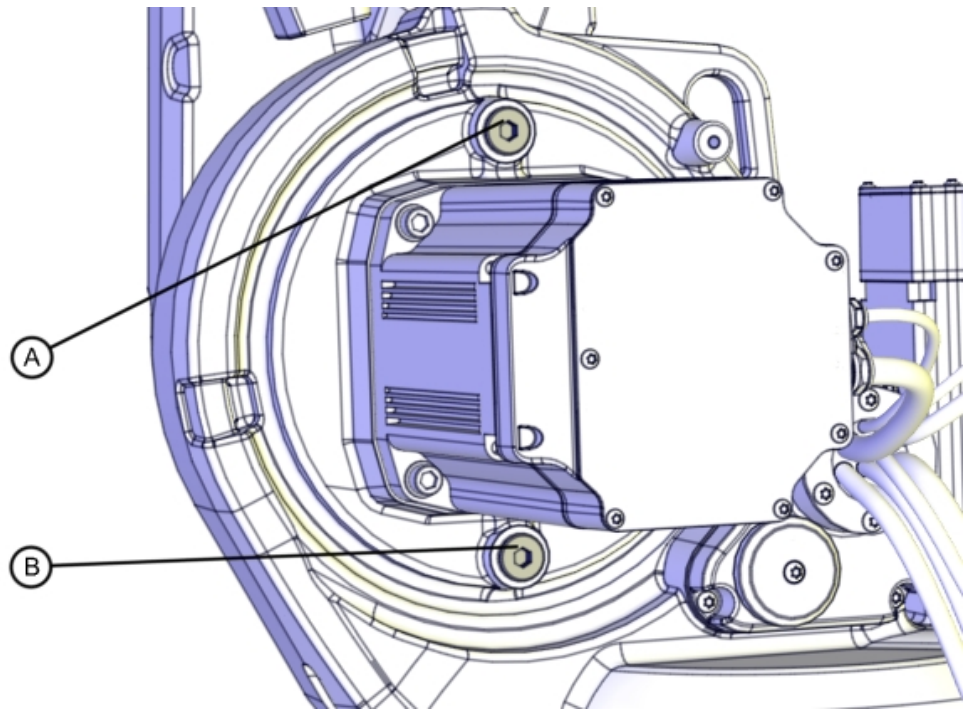

xx080000305

A	Oil plug, filling (draining when suspended mounted)
B	Oil plug, draining (filling when suspended mounted) (Quick connect fitting)

#### Required equipment

Equipment	Note
Oil plug sealing washer, gearbox	3HAC029646-001
Lubricating oil	Information about the oil is found in <i>Technical reference manual - Lubrication in gearboxes</i> . See <a href="#">Type and amount of oil in gearboxes on page 151</a> .
Oil collecting vessel	The capacity of the vessel must be sufficient to take the complete amount of oil.
Nipple (TEMA IF 3820 S06)	To be fitted on a hose, and then used for draining connected to the <i>quick connect fitting</i> . See <a href="#">Location of oil plugs on page 165</a> .
Standard toolkit	Content is defined in section <a href="#">Standard tools on page 398</a> .

Continues on next page

### 3 Maintenance

#### 3.5.4 Changing the oil, axis-2 gearbox

*Continued*

#### Additional equipment - Foundry Prime

Equipment	Art. no.	Note
Rust preventive	3HAC034903-001	Mercasol
Sikaflex 521FC	3HAC026759-001	
Loctite 574	12340011-116	
Brush		
Foundry Prime touch up kit	3HAC035355-001	



#### CAUTION





Always cut the paint with a knife and grind the paint edge when disassembling parts. See [Cut the paint or surface on the robot before replacing parts on page 200](#).

#### Draining, axis-2 gearbox

Use this procedure to drain the gearbox of oil.



	Action	Note
1	<p><b>DANGER</b></p> <p>Turn off all:</p> <ul style="list-style-type: none"> <li>• electric power supply</li> <li>• hydraulic pressure supply</li> </ul> <p>to the robot, before entering the robot working area.</p>	
2	<p><b>WARNING</b></p> <p>Handling gearbox oil involves several safety risks, see <a href="#">Gearbox lubricants (oil or grease) on page 34</a>.</p>	
3	<p><b>CAUTION</b></p> <p>The gearbox can contain an <i>excess of pressure</i> that can be hazardous. Open the oil plug carefully in order to let out the excess pressure.</p>	
4	<p>Either</p> <ul style="list-style-type: none"> <li>• connect a nipple to the <i>quick connect fitting</i> in the hole for draining</li> </ul> <p>or</p> <ul style="list-style-type: none"> <li>• remove the <i>quick connect fitting</i>.</li> </ul>	<p>See the figure in:</p> <ul style="list-style-type: none"> <li>• <a href="#">Location of oil plugs on page 165</a></li> </ul>
5	<p>Open the <i>oil plug, filling</i>.</p>	<p>See the figure in:</p> <ul style="list-style-type: none"> <li>• <a href="#">Location of oil plugs on page 165</a></li> </ul> <p><b>Note</b></p> <p>Drainage will be quicker if the oil plug, filling is removed.</p>

*Continues on next page*

	Action	Note
6	Drain the gearbox oil using an <i>oil collecting vessel</i> .	 <b>Note</b> Draining is time-consuming. Elapsed time varies depending on the temperature of the oil.
7	 <b>WARNING</b> Used oil is hazardous material and must be disposed of in a safe way. See section <a href="#">Decommissioning on page 387</a> for more information.	
8	 <b>Note</b> There will be some oil left in the gearbox after draining.	
9	Refit <i>oil plug</i> .  <b>Note</b> Before refitting the oil plug in the gearbox, always replace the oil plug sealing washer with a new one. If not there is a risk of leakage.	Tightening torque: <ul style="list-style-type: none"> <li>• 24 Nm</li> </ul>

#### Filling oil, axis-2 gearbox

Use this procedure to fill the gearbox with oil.



	Action	Note
1	 <b>DANGER</b> Turn off all: <ul style="list-style-type: none"> <li>• electric power supply</li> <li>• hydraulic pressure supply</li> </ul> to the robot, before entering the robot working area.	
2	 <b>WARNING</b> Handling gearbox oil involves several safety risks, see <a href="#">Gearbox lubricants (oil or grease) on page 34</a> .	
3	 <b>CAUTION</b> The gearbox can contain an <i>excess of pressure</i> that can be hazardous. Open the oil plug carefully in order to let out the excess pressure.	

Continues on next page

### 3 Maintenance

#### 3.5.4 Changing the oil, axis-2 gearbox

Continued

	Action	Note
4	Open <i>oil plug, filling</i> .	See the figure in: <ul style="list-style-type: none"><li>• <a href="#">Location of oil plugs on page 165</a></li></ul>
5	Refill the gearbox with <i>lubrication oil</i> .  <b>Note</b> The amount of oil to be filled depends on the amount previously being drained.	Where to find type of oil and total amount is detailed in <a href="#">Type and amount of oil in gearboxes on page 151</a> .
6	Inspect the oil level.	How to inspect the oil level is described in section: <ul style="list-style-type: none"><li>• <a href="#">Inspecting the oil level, axis 2 gearbox on page 121</a></li></ul>
7	Refit <i>oil plug</i> .  <b>Note</b> Before refitting the oil plug in the gearbox, always replace the oil plug sealing washer with a new one. If not there is a risk of leakage.	Tightening torque: <ul style="list-style-type: none"><li>• 24 Nm</li></ul>
8	Seal and paint the joints that have been opened. Also repair possible damages of the special Foundry Prime paint coat of the robot. See <a href="#">Cut the paint or surface on the robot before replacing parts on page 200</a> .	

### 3.5.5 Changing the oil, axis-3 gearbox

#### Location of oil plugs

The axis-3 gearbox is located in the upper arm rotational center.

Oil plugs are shown in the figure.

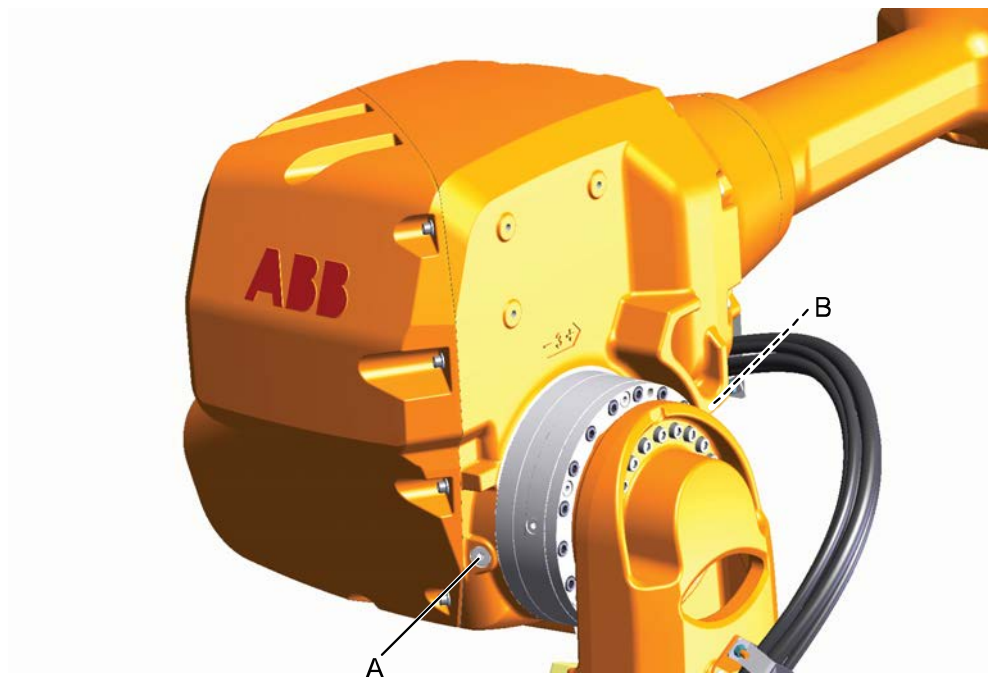

xx080000306

A	Oil plug, armhouse
B	Oil plug, gearbox (not visible in this figure)

#### Required equipment

Equipment	Note
Lubricating oil	Information about the oil is found in <i>Technical reference manual - Lubrication in gearboxes</i> . See <a href="#">Type and amount of oil in gearboxes on page 151</a> .
Oil collecting vessel	The capacity of the vessel must be sufficient to take the complete amount of oil.
Oil dispenser	One example of oil dispenser can be found in section: <ul style="list-style-type: none"> <li><a href="#">Type of lubrication in gearboxes on page 151</a></li> </ul>
Funnel	 <p>xx1200000862</p>

Continues on next page

### 3 Maintenance

#### 3.5.5 Changing the oil, axis-3 gearbox

*Continued*

Equipment	Note
Standard toolkit	Content is defined in section <a href="#">Standard tools on page 398</a> .

#### Additional equipment - Foundry Prime

Equipment	Art. no.	Note
Rust preventive	3HAC034903-001	Mercasol
Sikaflex 521FC	3HAC026759-001	
Loctite 574	12340011-116	
Brush		
Foundry Prime touch up kit	3HAC035355-001	



#### CAUTION

Always cut the paint with a knife and grind the paint edge when disassembling parts. See [Cut the paint or surface on the robot before replacing parts on page 200](#).



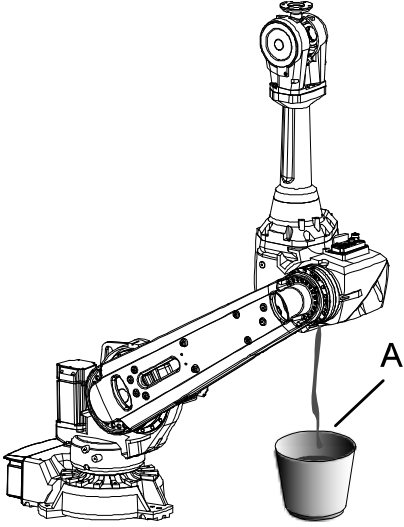

#### Draining, axis-3 gearbox

Use this procedure to drain the gearbox of oil.

There is an alternative method to drain the gearbox. See [Draining - alternative method on page 171](#).

Action	Note
1 Move the robot to an upright position as shown in the figure.	 <p>xx0800000327</p> <ul style="list-style-type: none"> <li>A: Oil collecting vessel</li> </ul>

*Continues on next page*

	Action	Note
2	 <b>DANGER</b> Turn off all: <ul style="list-style-type: none"> <li>• electric power supply</li> <li>• hydraulic pressure supply</li> </ul> to the robot, before entering the robot working area.	
3	 <b>WARNING</b> Handling gearbox oil involves several safety risks, see <a href="#">Gearbox lubricants (oil or grease) on page 34</a> .	
4	 <b>CAUTION</b> The gearbox can contain an <i>excess of pressure</i> that can be hazardous. Open the oil plug carefully in order to let out the excess pressure.	
5	Open the <i>oil plug, armhouse</i>	See the figure in: <ul style="list-style-type: none"> <li>• <a href="#">Location of oil plugs on page 169</a></li> </ul>
6	Open the <i>oil plug, gearbox</i> and use it as a ventilation hole.	See the figure in: <ul style="list-style-type: none"> <li>• <a href="#">Location of oil plugs on page 169</a></li> </ul>
7	Drain the gearbox oil using an <i>oil collecting vessel</i> .	 <b>Note</b> Draining is time-consuming. Elapsed time varies depending on the temperature of the oil.
8	 <b>WARNING</b> Used oil is hazardous material and must be disposed of in a proper way. See section <i>Decommissioning</i> for more information.	
9	Refit oil plugs.	Tightening torque: <ul style="list-style-type: none"> <li>• in armhouse: 10 Nm</li> <li>• in gearbox: 3 Nm</li> </ul>

#### Draining - alternative method

Use this procedure to drain the oil from the gearbox, as an alternative method.

If this method is used, oil must be sucked out of the gearbox using an oil dispenser.





	Action	Note
1	Move the upper arm of the robot to a position where the <i>oil plug, gearbox</i> is pointing at the floor.	See the figure in: <ul style="list-style-type: none"> <li>• <a href="#">Location of oil plugs on page 169</a></li> </ul>

*Continues on next page*

### 3 Maintenance

#### 3.5.5 Changing the oil, axis-3 gearbox

Continued

	Action	Note
2	 <b>DANGER</b> Turn off all: <ul style="list-style-type: none"> <li>• electric power supply</li> <li>• hydraulic pressure supply</li> </ul> to the robot, before entering the robot working area.	
3	 <b>CAUTION</b> The gearbox can contain an <i>excess of pressure</i> that can be hazardous. Open the oil plug carefully in order to let out the excess pressure.	
4	Use an <i>oil dispenser</i> fitted to the <i>oil plug, gearbox</i> to drain the oil.	An example of oil dispenser is detailed in section: <ul style="list-style-type: none"> <li>• <a href="#">Type of lubrication in gearboxes on page 151</a></li> </ul> See the figure in: <ul style="list-style-type: none"> <li>• <a href="#">Location of oil plugs on page 169</a></li> </ul>
5	Replace the <i>oil plug, gearbox</i> with a nipple where a draining hose is fitted.	See the figure in: <ul style="list-style-type: none"> <li>• <a href="#">Location of oil plugs on page 169</a></li> </ul>
6	Connect the <i>oil dispenser</i> .	One example can be found in section: <ul style="list-style-type: none"> <li>• <a href="#">Type of lubrication in gearboxes on page 151</a></li> </ul>
7	Open the <i>oil plug, armhouse</i> now pointing upwards and use it as a ventilation hole.	See the figure in: <ul style="list-style-type: none"> <li>• <a href="#">Location of oil plugs on page 169</a></li> </ul>  <b>WARNING</b> The oil plug, gearbox must be open when the oil dispenser equipment is used! Otherwise sealings and other parts will be damaged.
8	Start sucking the oil out from the gearbox with the oil ejector equipment.	For capacity of the vessel see section: <ul style="list-style-type: none"> <li>• <a href="#">Type of lubrication in gearboxes on page 151</a></li> </ul>
9	 <b>WARNING</b> Used oil is hazardous material and must be disposed of in a proper way. See section <i>Decommissioning</i> for more information.	
10	 <b>Note</b> There will be some oil left in the gearbox after draining!	





Continues on next page

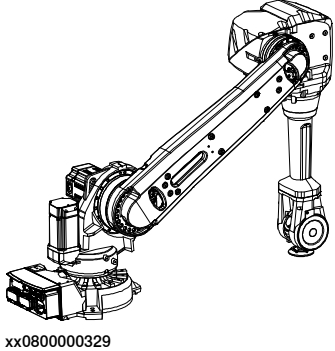

	Action	Note
11	Refit the <i>oilplugs</i> .	See the figure in: <ul style="list-style-type: none"> <li>• <a href="#">Location of oil plugs on page 169</a></li> </ul> Tightening torque: <ul style="list-style-type: none"> <li>• in armhouse: 10 Nm</li> <li>• in gearbox: 3 Nm</li> </ul>

#### Filling oil, axis-3 gearbox

Use this procedure to fill the gearbox with oil.



	Action	Note
1	Move the upper arm to a position where the wrist is pointing towards the floor as shown in the figure.	
2	 <b>DANGER</b> Turn off all: <ul style="list-style-type: none"> <li>• electric power supply</li> <li>• hydraulic pressure supply</li> </ul> to the robot, before entering the robot working area.	
3	 <b>WARNING</b> Handling gearbox oil involves several safety risks, see <a href="#">Gearbox lubricants (oil or grease) on page 34</a> .	
4	 <b>CAUTION</b> The gearbox can contain an <i>excess of pressure</i> that can be hazardous. Open the oil plug carefully in order to let out the excess pressure.	
5	Open the <i>oil plug, armhouse</i> .	See the figure in: <ul style="list-style-type: none"> <li>• <a href="#">Location of oil plugs on page 169</a></li> </ul>

Continues on next page

### 3 Maintenance

#### 3.5.5 Changing the oil, axis-3 gearbox

Continued

	Action	Note
6	<p>Refill the gearbox with <i>lubricating oil</i>.</p> <p> <b>Tip</b></p> <p>Use a funnel.</p> <p> <b>Note</b></p> <p>The amount of oil to be filled depends on the amount previously being drained.</p>	<p>Where to find type of oil and total amount is detailed in <a href="#">Type and amount of oil in gearboxes on page 151</a>.</p>
7	<p>Inspect the <i>oil level</i>.</p>	<p>How to inspect oil is described in section:</p> <ul style="list-style-type: none"><li>• <a href="#">Inspecting the oil level, axis 3 gearbox on page 124</a></li></ul>
8	<p>Refit the <i>oil plug</i>.</p>	<p>Tightening torque:</p> <ul style="list-style-type: none"><li>• in armhouse: 10 Nm</li><li>• in gearbox: 3 Nm</li></ul>
9	<p>Seal and paint the joints that have been opened. Also repair possible damages of the special Foundry Prime paint coat of the robot. See <a href="#">Cut the paint or surface on the robot before replacing parts on page 200</a>.</p>	

3.5.6 Changing the oil, axis-4 gearbox

Location of oil plugs

The axis-4 gearbox is located in the front of the upper armhouse.  
The oil plug is shown in the figure.

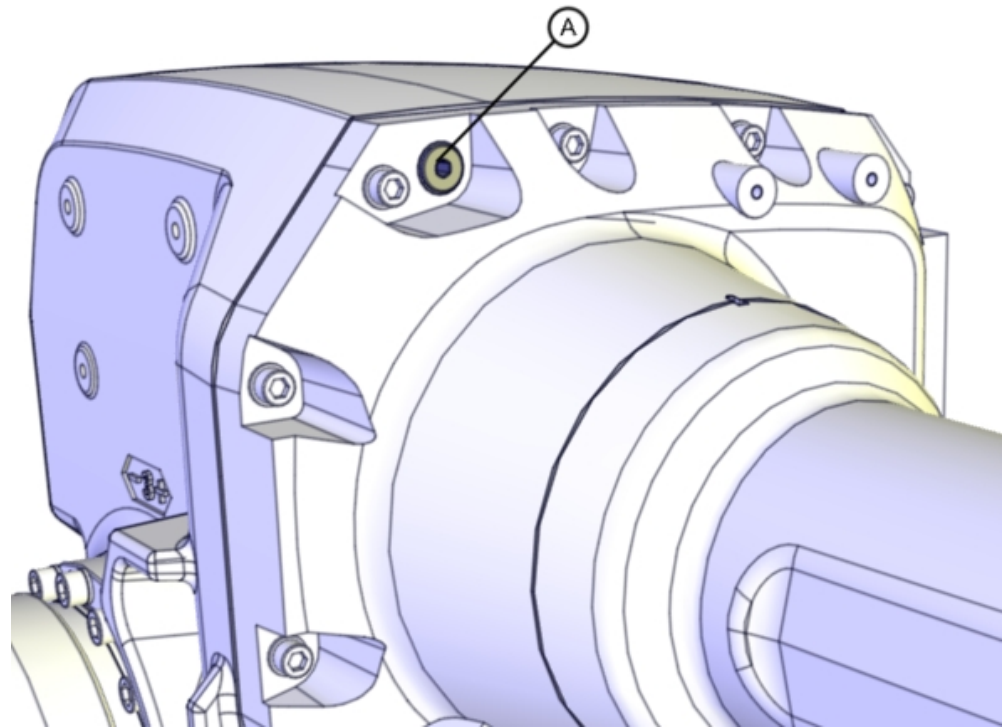

xx080000307

A	Oil plug, for filling and draining
---	------------------------------------

Required equipment

Equipment	Note
Lubricating oil	Where to find information of the <i>type of oil</i> , <i>article number</i> and the <i>amount</i> in the gearbox, see section <a href="#">Type of lubrication in gear-boxes on page 151</a>
Oil collecting vessel	The capacity of the vessel must be sufficient to take the complete amount of oil.
Plastic hose	Used for venting the gearbox during draining. A suitable hose would be a hose normally used for compressed air. Length: minimum 300 mm. Diameter: 5 mm.
Funnel	 xx120000862

Continues on next page

### 3 Maintenance

#### 3.5.6 Changing the oil, axis-4 gearbox

Continued

Equipment	Note
Standard toolkit	Content is defined in section <a href="#">Standard tools on page 398</a> .

#### Additional equipment - Foundry Prime

Equipment	Art. no.	Note
Rust preventive	3HAC034903-001	Mercasol
Sikaflex 521FC	3HAC026759-001	
Loctite 574	12340011-116	
Brush		
Foundry Prime touch up kit	3HAC035355-001	





#### CAUTION



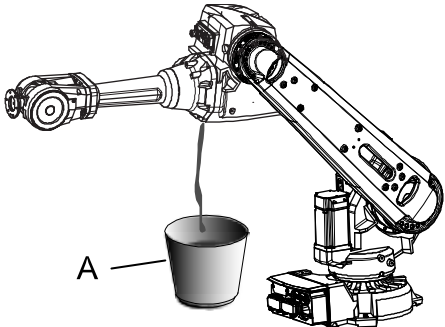

Always cut the paint with a knife and grind the paint edge when disassembling parts. See [Cut the paint or surface on the robot before replacing parts on page 200](#).

#### Draining oil

Use this procedure to drain oil from the gearbox.

	Action	Note
1	Move the robot to the position shown in the figure.	 <p>xx0800000328</p> <ul style="list-style-type: none"> <li>A: Oil collecting vessel</li> </ul>
2	 <p><b>DANGER</b></p> <p>Turn off all:</p> <ul style="list-style-type: none"> <li>electric power supply</li> <li>hydraulic pressure supply</li> </ul> <p>to the robot, before entering the robot working area.</p>	
3	 <p><b>WARNING</b></p> <p>Handling gearbox oil involves several safety risks, see <a href="#">Gearbox lubricants (oil or grease) on page 34</a>.</p>	

Continues on next page

	Action	Note
4	<p> <b>CAUTION</b></p> <p>The gearbox can contain an <i>excess of pressure</i> that can be hazardous. Open the oil plug carefully in order to let out the excess pressure.</p>	
5	Open oil plug, draining.	See the figure in: <ul style="list-style-type: none"> <li>• <a href="#">Location of oil plugs on page 175</a></li> </ul>
6	<p>Drain the gearbox oil using an <i>oil collecting vessel</i>.</p> <p> <b>Tip</b></p> <p>Insert a compressed air hose approximately 100 mm into the gearbox, to vent the gearbox. This speeds up the draining significantly.</p>	<p> <b>Note</b></p> <p>Draining is time-consuming. Elapsed time varies depending on the temperature of the oil.</p>
7	<p> <b>WARNING</b></p> <p>Used oil is hazardous material and must be disposed of in a safe way. See section <a href="#">Decommissioning on page 387</a> for more information.</p>	
8	Refit the oil plug.	Tightening torque: 10 Nm.

#### Filling oil

Use this procedure to fill oil in the gearbox.

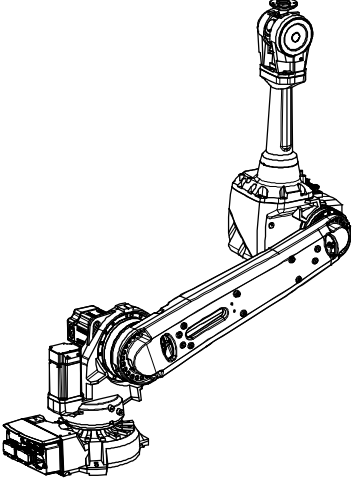



	Action	Note
1	Move the upper arm to the position shown in the figure.	 <p>xx0800000330</p>

*Continues on next page*

### 3 Maintenance

#### 3.5.6 Changing the oil, axis-4 gearbox

Continued

	Action	Note
2	 <b>DANGER</b> Turn off all: <ul style="list-style-type: none"> <li>• electric power supply</li> <li>• hydraulic pressure supply</li> </ul> to the robot, before entering the robot working area.	
3	 <b>WARNING</b> Handling gearbox oil involves several safety risks, see <a href="#">Gearbox lubricants (oil or grease) on page 34</a> .	
4	 <b>CAUTION</b> The gearbox can contain an <i>excess of pressure</i> that can be hazardous. Open the oil plug carefully in order to let out the excess pressure.	
5	Open the <i>oil plug, filling</i> .	See the figure in: <ul style="list-style-type: none"> <li>• <a href="#">Location of oil plugs on page 175</a></li> </ul>
6	Refill the gearbox with <i>lubricating oil</i> .  <b>Tip</b> Use a funnel.  <b>Note</b> The amount of oil to be filled depends on the amount previously being drained.	Where to find type of oil and total amount is detailed in <a href="#">Type and amount of oil in gearboxes on page 151</a> .
7	Refit the <i>oil plug</i> .	Tightening torque: 10 Nm.
8	Seal and paint the joints that have been opened. Also repair possible damages of the special Foundry Prime paint coat of the robot. See <a href="#">Cut the paint or surface on the robot before replacing parts on page 200</a> .	

### 3.5.7 Changing oil, axes-5 and -6 gearboxes

#### Location of oil plugs

The axes-5 and -6 gearboxes are located in the wrist unit.

The oil plug is shown in the figure.

The figure shows wrist variant 60 kg

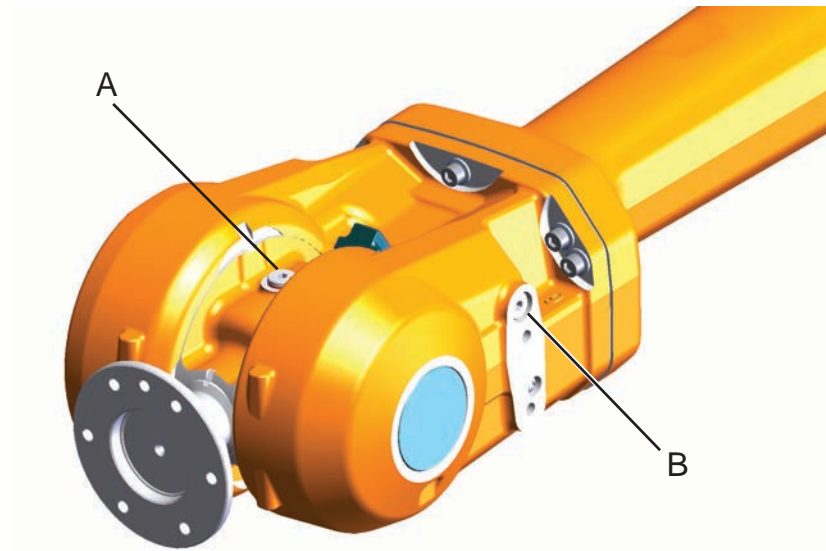

xx0800000308

A	Oil plug, tilthouse
B	Oil plug, wrist unit (also used as air inlet when draining from oil plug A)



#### Note

The gearboxes for axes-5 and -6 are the same.

#### Required equipment

Equipment	Note
Lubrication oil	Where to find information of the <i>type of oil</i> , <i>article number</i> and the <i>amount</i> in the gearbox, see section: <a href="#">Type of lubrication in gearboxes on page 151</a>
Oil collecting vessel	The capacity of the vessel must be sufficient to take the complete amount of oil.
Standard toolkit	Content is defined in section <a href="#">Standard tools on page 398</a> .

#### Additional equipment - Foundry Prime

Equipment	Art. no.	Note
Rust preventive	3HAC034903-001	Mercasol
Sikaflex 521FC	3HAC026759-001	

*Continues on next page*

### 3 Maintenance

#### 3.5.7 Changing oil, axes-5 and -6 gearboxes

Continued

Equipment	Art. no.	Note
Loctite 574	12340011-116	
Brush		
Foundry Prime touch up kit	3HAC035355-001	



#### CAUTION

Always cut the paint with a knife and grind the paint edge when disassembling parts. See [Cut the paint or surface on the robot before replacing parts on page 200](#).



#### Draining axes-5 and -6 gearbox - wrist 60 kg

Use this procedure to drain oil from the gearbox.





#### CAUTION

The gearbox can contain an *excess of pressure* that can be hazardous. Open the oil plug carefully in order to let out the excess pressure.

	Action	Note
1	Move the <i>upper arm</i> to a position where it points downwards.	
2	Move axis 5 to a position where the <i>oil plug, tilthouse</i> points downwards.	The turning disk shall be in a horizontal position.
3	 <b>DANGER</b> Turn off all: <ul style="list-style-type: none"> <li>• electric power supply</li> <li>• hydraulic pressure supply</li> </ul> to the robot, before entering the robot working area.	
4	 <b>WARNING</b> Handling gearbox oil involves several safety risks, see <a href="#">Gearbox lubricants (oil or grease) on page 34</a> .	
5	Put an <i>oil collecting vessel</i> under the wrist in order to collect drained oil.	The capacity of the vessel must be sufficient to take the complete amount of oil.
6	Open the <i>oil plug, tilthouse</i> .	See the figure in: <ul style="list-style-type: none"> <li>• <a href="#">Location of oil plugs on page 179</a></li> </ul>
7	Open the oil plug, wrist (air inlet). This is done for the ventilation of the gearbox and to facilitate draining.	See the figure in: <ul style="list-style-type: none"> <li>• <a href="#">Location of oil plugs on page 179</a></li> </ul>

Continues on next page





	Action	Note
8	Drain the gearbox.	 <b>Note</b> Draining is time-consuming. Elapsed time varies depending on the temperature of the oil.
9	 <b>WARNING</b> Used oil is hazardous material and must be disposed of in a safe way. See section <a href="#">Decommissioning on page 387</a> for more information.	

#### Filling oil axes-5 and -6 gearbox - wrist 60 kg

Use this procedure to fill oil in the gearbox.

 <b>CAUTION</b> The gearbox can contain an <i>excess of pressure</i> that can be hazardous. Open the oil plug carefully in order to let out the excess pressure.
--



	Action	Note
1	Move the upper arm to a position where the <i>oil plug, wrist</i> points upwards.	See the figure in: <ul style="list-style-type: none"> <li>• <a href="#">Location of oil plugs on page 179</a></li> </ul>
2	Move axis-5 to a position where the <i>oil plug, tilthouse</i> points upwards.	See the figure in: <ul style="list-style-type: none"> <li>• <a href="#">Location of oil plugs on page 179</a></li> </ul>
3	 <b>DANGER</b> Turn off all: <ul style="list-style-type: none"> <li>• electric power supply</li> <li>• hydraulic pressure supply</li> </ul> to the robot, before entering the robot working area.	
4	 <b>WARNING</b> Handling gearbox oil involves several safety risks, see <a href="#">Gearbox lubricants (oil or grease) on page 34</a> .	
5	Open <i>oil plug, wrist</i> .	See the figure in: <ul style="list-style-type: none"> <li>• <a href="#">Location of oil plugs on page 179</a></li> </ul>
6	Open <i>oil plug, tilthouse</i> .	See the figure in: <ul style="list-style-type: none"> <li>• <a href="#">Location of oil plugs on page 179</a></li> </ul>

*Continues on next page*

### 3 Maintenance

#### 3.5.7 Changing oil, axes-5 and -6 gearboxes

Continued

	Action	Note
7	Refill oil using <i>oil plug, wrist</i> .  <b>Note</b> There will be some oil left in the gearbox after draining.	There will be oil left in the gearbox after draining. Therefore the amount of oil filled will be less than the total amount. When filling oil in a wrist (60 kg) begin by only filling 1.500 ml. Check oil level. If needed add more oil.
8	Refill the gearbox with <i>lubrication oil</i> .  <b>Note</b> The amount of oil to be filled depends on the amount previously being drained.	Where to find type of oil and total amount is detailed in <a href="#">Type and amount of oil in gearboxes on page 151</a> .
9	Inspect the <i>oil level</i> .	How to inspect the oil level is described in section: <ul style="list-style-type: none"> <li>• <a href="#">Inspecting oil level, gearbox axes 5 - 6 on page 128</a></li> </ul>
10	Refit both oil plugs.	Tightening torque: <ul style="list-style-type: none"> <li>• 10 Nm</li> </ul>
11	Seal and paint the joints that have been opened. Also repair possible damages of the special Foundry Prime paint coat of the robot. See <a href="#">Cut the paint or surface on the robot before replacing parts on page 200</a> .	

### 3.5.8 Replacing SMB battery



#### Note

The battery low alert (38213 **Battery charge low**) is displayed when the battery needs to be replaced. The recommendation to avoid an unsynchronized robot is to keep the power to the controller turned on until the battery is to be replaced. For an SMB board with 3-pole battery contact (RMU101 3HAC044168-001 or RMU102 3HAC043904-001), the lifetime of a new battery is typically 36 months. For an SMB board with 2-pole battery contact, the typical lifetime of a new battery is 36 months if the robot is powered off 2 days/week or 18 months if the robot is powered off 16 h/day. The lifetime can be extended for longer production breaks with a battery shutdown service routine. See *Operating manual - IRC5 with FlexPendant* or *Operating manual - OmniCore* for instructions.



#### WARNING

See [Hazards related to batteries on page 35](#).

*Continues on next page*

### 3 Maintenance

#### 3.5.8 Replacing SMB battery

*Continued*

#### Location of SMB battery

The SMB battery is located at the base of the robot, as shown in the figure.

DSQC 633A

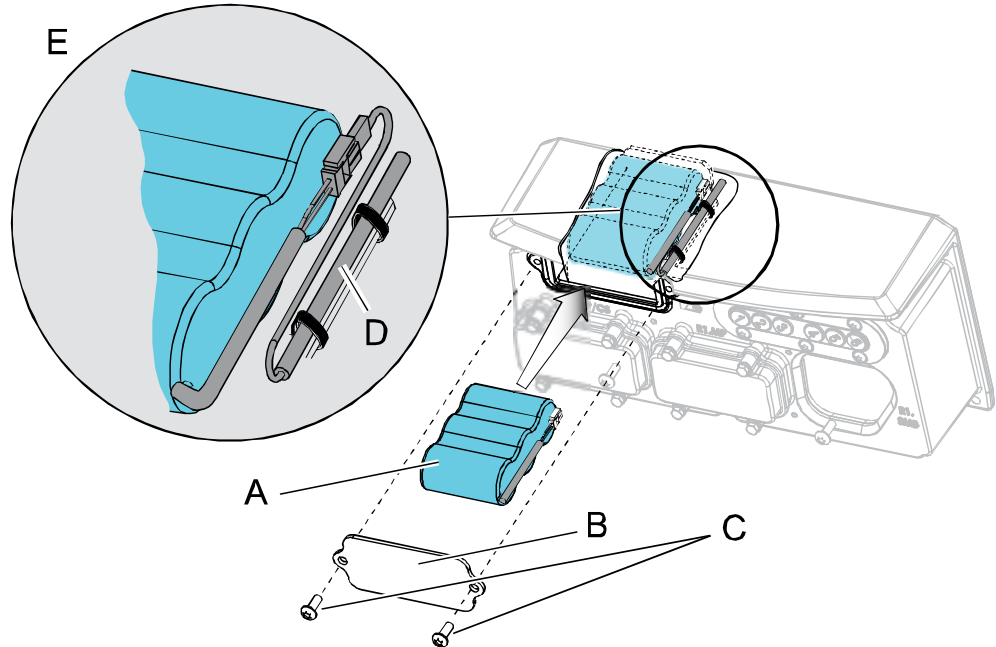

xx0800000322

A	SMB battery (2-pole battery contact)
B	Battery cover
C	Attachment screws
D	SMB battery cable
E	How to arrange the battery cable

*Continues on next page*

RMU 101

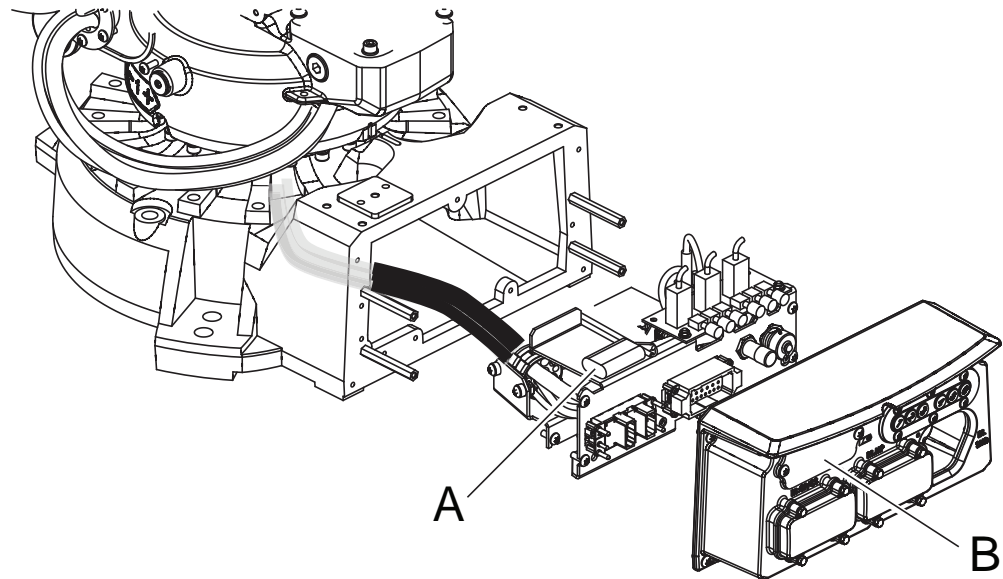

xx130000339

A	SMB battery (3-pole battery contact)
B	Battery cover

#### Required equipment



#### Note

There are two variants of SMB units and batteries. One with 2-pole battery contact and one with 3-pole battery contact. The variant with the 3-pole battery contact has longer lifetime for the battery.

It is important that the SMB unit uses the correct battery. Make sure to order the correct spare parts. Do not replace the battery contact!

Equipment	Note
SMB battery pack	Battery includes protection circuits. Replace it only with given spare part no. or an ABB approved equivalent. See <a href="#">Spare part lists on page 403</a> .
Standard toolkit	Content is defined in section <a href="#">Standard tools on page 398</a> .
Circuit diagram	See chapter <a href="#">Circuit diagram on page 405</a> .

#### Additional equipment - Foundry Prime

Equipment	Art. no.	Note
Rust preventive	3HAC034903-001	Mercasol
Sikaflex 521FC	3HAC026759-001	
Loctite 574	12340011-116	
Brush		
Foundry Prime touch up kit	3HAC035355-001	

Continues on next page

## 3 Maintenance

### 3.5.8 Replacing SMB battery

*Continued*







#### CAUTION

Always cut the paint with a knife and grind the paint edge when disassembling parts. See [Cut the paint or surface on the robot before replacing parts on page 200](#).

### Removing SMB battery



Use this procedure to remove the SMB battery.

	Action	Note
1	Move the robot to its calibration position.	This is done in order to facilitate the updating of the revolution counter.
2	 <b>DANGER</b> Turn off all: <ul style="list-style-type: none"><li>• electric power supply</li><li>• hydraulic pressure supply</li></ul> to the robot, before entering the robot working area.	
3	 <b>ELECTROSTATIC DISCHARGE (ESD)</b> The unit is sensitive to ESD. Before handling the unit please read the safety information in the section <a href="#">The unit is sensitive to ESD on page 56</a>	
4	 <b>CAUTION</b> Always cut the paint with a knife and grind the paint edge when disassembling parts. See <a href="#">Cut the paint or surface on the robot before replacing parts on page 200</a> .	
5	Remove the <i>SMB battery cover</i> .  <b>CAUTION</b> Clean cover from metal residues before opening. Metal residues can cause shortage on the boards which can result in hazardous failures.	See the figure in <a href="#">Location of SMB battery on page 184</a> .
6	Pull out the <i>SMB battery</i> .	See the figure in <a href="#">Location of SMB battery on page 184</a> .
7	Disconnect the <i>battery cable</i> and remove the battery.	See the figure in <a href="#">Location of SMB battery on page 184</a> .
8	How to dispose of the used SMB battery, see chapter <a href="#">Decommissioning on page 387</a> .	

*Continues on next page*

#### Refitting SMB battery

Use this procedure to refit the SMB battery.

	Action	Note
1	 <b>DANGER</b>  Turn off all: <ul style="list-style-type: none"> <li>• electric power supply</li> <li>• hydraulic pressure supply</li> </ul> to the robot, before entering the robot working area.	
2	 <b>ELECTROSTATIC DISCHARGE (ESD)</b>  The unit is sensitive to ESD. Before handling the unit please read the safety information in the section <a href="#">The unit is sensitive to ESD on page 56</a>	
3	Reconnect the <i>battery cable</i> to the <i>SMB battery</i> .	See the figure in <a href="#">Location of SMB battery on page 184</a> .
4	Put the battery unit into its recess while arranging the SMB cables as shown in the figure.	See the figure in <a href="#">Location of SMB battery on page 184</a> .
5	Secure the <i>SMB cover</i> with its <i>attachment screws</i> .	See the figure in <a href="#">Location of SMB battery on page 184</a> .
6	Seal and paint the joints that have been opened. Also repair possible damages of the special Foundry Prime paint coat of the robot. See <a href="#">Cut the paint or surface on the robot before replacing parts on page 200</a> .	
7	Update the revolution counter.	Detailed in <a href="#">Updating revolution counters on IRC5 robots on page 361</a> .
8	 <b>DANGER</b>  Make sure all safety requirements are met when performing the first test run.	

## 3 Maintenance

---

### 3.6.1 Analyzing the water content in gearbox oil

## 3.6 Analysis activities

### 3.6.1 Analyzing the water content in gearbox oil

---

#### Analysis of the water content

It is recommended to check for water content in the oil every 12 month.



#### Note

When the oil is analyzed for water, the oil level must also be checked. See [Inspection activities on page 115](#).

---

#### Recommendations

##### Recommendations for oil in axes 1, 2, 3 and 6

If water content is:

- 0-1.5 vol %; measure water content in oil again after 12 months of operation
- 1.5- 2 vol %; change oil in gear latest within 12 months
- >2 vol %; change oil in gear latest within 6 months
- >3 vol %; it is recommended to replace the gearbox, see [Gearboxes on page 325](#)

If water content in oil remains <1.5 vol %; change oil at latest after 20 000 hours of operation.

##### Recommendations for oil in axes 4 and 5

No oil analysis is necessary. Change oil periodically, at latest every 18 months.



## 3.7 Cleaning activities

### 3.7.1 Cleaning the IRB 4600 Foundry Prime



#### DANGER

Turn off all:

- electric power supply
- hydraulic pressure supply

to the robot, before entering the safeguarded space.

#### General

To secure high uptime it is important that the IRB 4600 Foundry Prime is cleaned regularly. The frequency of cleaning depends on the environment in which the product works.

Different cleaning methods are allowed depending on the type of protection of the IRB 4600 Foundry Prime.



#### Note

Always verify the protection type of the robot before cleaning.

#### Oil spills

##### Oil spills from gearboxes

Use the following procedure if any oil spills are detected that can be suspected to originate from a gearbox.

- 1 Inspect that the oil level in the suspected gearbox is according to the recommendations, see [Inspection activities on page 115](#).
- 2 Write down the oil level.
- 3 Inspect the oil level again after, for example, 6 months.
- 4 If the oil level is decreased then replace the gearbox.

##### Oil spills discolors painted surfaces

Oil spills on painted surfaces of the robot can result in discoloration.



#### Note

After all repair and maintenance work involving oil, always wipe the robot clean from all surplus oil.

#### Special cleaning considerations

This section specifies some special considerations when cleaning the robot.

- Always use cleaning equipment as specified. Any other cleaning equipment may shorten the life of the robot.

*Continues on next page*

## 3 Maintenance

### 3.7.1 Cleaning the IRB 4600 Foundry Prime

Continued

- Always check that all protective covers are fitted to the robot before cleaning.
- Never point the water jet at connectors, joints, sealings, or gaskets.
- Do not use compressed air to clean the robot.
- Never use solvents that are not approved by ABB to clean the robot.
- Do not spray from a distance closer than 0.4 m.
- Do not remove any covers or other protective devices before cleaning the robot.

#### Cleaning methods

The following table defines what cleaning methods are allowed depending on the protection type.

Protection type	Cleaning method			
	Vacuum cleaner	Wipe with cloth	Rinse with water	High pressure water or steam
Foundry Prime	Yes	Yes. With cleaning detergent approved by ABB, spirit or isopropyl alcohol. <a href="#">See <i>Approved cleaners and detergents</i> on page 191.</a>	Yes. It is highly recommended that the water contains a rust-prevention solution.	Yes <sup>i</sup> . It is highly recommended that the water and steam contains rust preventive. If cleaning detergents are used they must be approved by ABB for Foundry Prime robots. <a href="#">See <i>Approved cleaners and detergents</i> on page 191.</a>

<sup>i</sup> Perform according to section [Cleaning with water and steam on page 190](#).

#### Cleaning with water and steam

##### Instructions for rinsing with water

ABB robots with protection types *Standard*, *Foundry Plus*, *Wash*, or *Foundry Prime* can be cleaned by rinsing with water (water cleaner).<sup>1</sup>

The following list defines the prerequisites:

- Maximum water pressure at the nozzle: 700 kN/m<sup>2</sup> (7 bar)<sup>1</sup>
- Fan jet nozzle should be used, min. 45° spread
- Minimum distance from nozzle to encapsulation: 0.4 meters
- Maximum flow: 20 liters/min<sup>1</sup>

<sup>1</sup> Typical tap water pressure and flow

##### Instructions for steam or high pressure water cleaning

ABB robots with protection types *Foundry Plus*, *Wash*, or *Foundry Prime* can be cleaned using a steam cleaner or high pressure water cleaner.<sup>2</sup>

The following list defines the prerequisites:

- Maximum water pressure at the nozzle: 2500 kN/m<sup>2</sup> (25 bar)
- Fan jet nozzle should be used, min. 45° spread
- Minimum distance from nozzle to encapsulation: 0.4 meters

<sup>1</sup> See [Cleaning methods on page 190](#) for exceptions.

<sup>2</sup> See [Cleaning methods on page 190](#) for exceptions.

Continues on next page

- Maximum water temperature: 80° C

---

#### Additional cleaning instructions for Foundry Prime robots

##### Washing detergents

- Only washing detergents approved by ABB shall be used.
- The washing detergent must be cleansed continuously.
- The washing detergent must contain rust inhibitor.
- The detergent pH value and concentration must be checked regularly.
- Allowed pH of the washing detergent is maximum 9.0.
- The user must follow the recommendations regarding detergent concentration and pH value.
- No other additive than water is guaranteed without prior testing or agreement with ABB. Other additives than water may have a harmful effect on the life of the robot and its components.
- Recommendations given by the detergent manufacturer for the specific detergent in question must be followed.



#### Note

If the pH value or the detergent concentration is varying from its original specification, it can become very corrosive.

##### Approved cleaners and detergents

All cleaners and detergents must be approved by ABB before use. Contact ABB Robotics Sales Support to get the latest released list of approved cleaners and detergents.

##### Temperature of cleaning bath

- Maximum temperature <60°C.  
Ambient temperature must not be higher than +45°C.



#### Note

Make sure that the special Foundry Prime painting of the robot is not broken during testing, installation, or repair work. Use the touch up kit available for Foundry Prime (article number 3HAC035355-001) to repair any damages in the paint.

##### Washing without detergent

If the washing is performed without detergent, the water must contain rust inhibitor.

---

#### Cables

Movable cables need to be able to move freely:

- Remove waste material, such as sand, dust and chips, if it prevents cable movement.
- Clean the cables if they have a crusty surface, for example from dry release agents.

**This page is intentionally left blank**

# 4 Repair

## 4.1 Introduction

### Structure of this chapter

This chapter describes repair activities for the IRB 4600 Foundry Prime. Each procedure contains the information required to perform the activity, for example spare parts numbers, required special tools, and materials.



#### WARNING

Repair activities not described in this chapter must only be carried out by ABB.

### Report replaced units



#### Note

When replacing a part on the IRB 4600 Foundry Prime, report to your local ABB the serial number, the article number, and the revision of both the replaced unit and the replacement unit.

This is particularly important for safety equipment to maintain the safety integrity of the installation.

### Safety information

Make sure to read through the chapter [Safety on page 19](#) before commencing any service work.



#### Note

If the IRB 4600 Foundry Prime is connected to power, always make sure that the IRB 4600 Foundry Prime is connected to protective earth and a residual current device (RCD) before starting any repair work.

For more information see:

- *Product manual - OmniCore V250XT*
- *Product manual - IRC5*
- *Product manual - IRC5 Panel Mounted Controller*

## 4 Repair

### 4.2.1 Performing a leak-down test

## 4.2 General procedures

### 4.2.1 Performing a leak-down test

#### When to perform a leak-down test

After refitting any motor and gearbox, the integrity of all seals enclosing the gearbox oil must be tested. This is done in a leak-down test.

#### Required equipment

Equipment, etc.	Article number	Note
Leak-down tester	-	
Leak detection spray	-	

#### Performing a leak-down test

	Action	Note
1	Finish the refitting procedure of the motor or gear in question.	
2	Remove the upper oil plug on the gear and replace it with the leak-down tester. Regulators, which are included in the leak-down test, may be required.	
3	Use caution, apply compressed air and raise the pressure with the knob until the correct value is shown on the manometer.  <b>CAUTION</b> The pressure must under no circumstance be higher than 0.25 bar (20-25 kPa). Also during the time when the pressure is raised.	Correct value: 0.2-0.25 bar (20-25 kPa)
4	Disconnect the compressed air supply.	
5	Wait for approximately 8-10 minutes and make sure that no pressure loss occurs.	If the compressed air is significantly colder or warmer than the gearbox to be tested, a slight pressure increase or decrease may occur. This is quite normal.
6	If any pressure drop occurred, then localize the leak as described in step 7. If no pressure drop occurred, then remove the leak-down tester and refit the oil plug. The test is complete.	
7	Spray any suspected leak areas with the leak detection spray. Bubbles indicate a leak.	
8	When the leak has been localized, take the necessary measures to correct the leak.	

## 4.2.2 Mounting instructions for bearings

### General

This section describes how to mount and grease different types of bearings on the robot.

### Equipment

Equipment, etc.	Article number	Note
Grease	3HAC042536-001	Shell Gadus S2 Used to grease the bearings, if not specified otherwise.

### Assembly of all bearings

Attend to the following instructions while mounting a bearing on the robot.

	Action	Note
1	To avoid contamination, let a new bearing remain in its wrapping until it is time for fitting.	
2	Ensure that the parts included in the bearing fitting are free from burrs, grinding waste, and other contamination. Cast components must be free of foundry sand.	
3	Bearing rings, inner rings, and roller elements must not be subjected to direct impact. The roller elements must not be exposed to any stresses during the assembly work.	

### Assembly of tapered bearings

Follow the preceding instructions for the assembly of the bearings when mounting a tapered bearing on the robot.

In addition to those instructions, the following procedure must be carried out to enable the roller elements to adjust to the correct position against the race flange.

	Action	Note
1	Tension the bearing gradually until the recommended pre-tension is achieved.   <b>Note</b> The roller elements must be rotated a specified number of turns before pre-tensioning is carried out and also rotated during the pre-tensioning sequence.	
2	Make sure the bearing is properly aligned as this will directly affect the durability of the bearing.	

### Greasing of bearings



#### Note

This instruction is not valid for solid oil bearings.

*Continues on next page*

## 4 Repair

---

### 4.2.2 Mounting instructions for bearings

*Continued*

The bearings must be greased after assembly according to the following instructions:

- The bearings must not be completely filled with grease. However, if space is available beside the bearing fitting, the bearing may be totally filled with grease when mounted, as excessive grease will be pressed out from the bearing when the robot is started.
- During operation, the bearing should be filled to 70-80% of the available volume.
- Ensure that grease is handled and stored properly to avoid contamination.

Grease the different types of bearings as following description:

- *Grooved ball bearings* must be filled with grease from both sides.
- *Tapered roller bearings* and axial needle bearings must be greased in the split condition.



### 4.2.3 Mounting instructions for sealings

#### General

This section describes how to mount different types of sealings.

#### Equipment

Consumable	Article number	Note
Grease	3HAC042536-001	Shell Gadus S2

#### Rotating sealings

The procedure below describes how to fit rotating sealings.



#### CAUTION

Please observe the following before commencing any assembly of sealings:

- Protect the sealing during transport and mounting, especially the main lip.
- Keep the sealing in its original wrappings or protect it well before actual mounting.
- The fitting of sealings and gears must be carried out on clean workbenches.
- Use a protective sleeve for the main lip during mounting, when sliding over threads, keyways or other sharp edges.

Action	Note
1 Check the sealing to ensure that: <ul style="list-style-type: none"> <li>• The sealing is of the correct type.</li> <li>• There is no damage on the main lip.</li> </ul>	
2 Inspect the shaft surface before mounting. If scratches or damage are found, the shaft must be replaced since it may result in future leakage. Do not try to grind or polish the shaft surface to get rid of the defect.	
3 Lubricate the sealing with grease just before fitting. (Not too early - there is a risk of dirt and foreign particles adhering to the sealing.) Fill 2/3 of the space between the dust lip and the main lip with grease. If the sealing is without dust lip, just lubricate the main lip with a thin layer of grease.	<p>Article number is specified in <a href="#">Equipment on page 197</a>.</p> <p>xx2000000071</p> <p>A Main lip B Grease C Dust lip</p>

*Continues on next page*

## 4 Repair

### 4.2.3 Mounting instructions for sealings

Continued

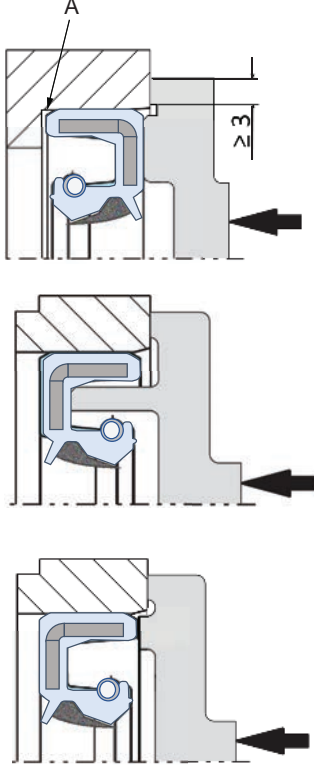
	Action	Note
4	<p>Mount the sealing correctly with a mounting tool. Never hammer directly on the sealing as this may result in leakage.</p>	 <p>xx2000000072</p> <p>A Gap</p>

### Flange sealings and static sealings

The following procedure describes how to fit flange sealings and static sealings.

	Action
1	<p>Check the flange surfaces. They must be even and free from pores. It is easy to check flatness using a gauge on the fastened joint (without sealing compound). If the flange surfaces are defective, the parts may not be used because leakage could occur.</p>
2	<p>Clean the surfaces properly in accordance with the recommendations of ABB.</p>
3	<p>Distribute the sealing compound evenly over the surface, preferably with a brush.</p>
4	<p>Tighten the screws evenly when fastening the flange joint.</p>

### O-rings

The following procedure describes how to fit o-rings.

	Action	Note
1	<p>Ensure that the correct o-ring size is used.</p>	
2	<p>Check the o-ring for surface defects, burrs, shape accuracy, or deformation.</p>	<p>Defective o-rings, including damaged or deformed o-rings, may not be used.</p>

Continues on next page

	<b>Action</b>	<b>Note</b>
3	Check the o-ring grooves. The grooves must be geometrically correct and should be free of pores and contamination.	
4	Lubricate the o-ring with grease.	
5	Tighten the screws evenly while assembling.	
6	Check that the o-ring is not squashed outside the o-ring groove.	

## 4 Repair

### 4.2.4 Cut the paint or surface on the robot before replacing parts

### 4.2.4 Cut the paint or surface on the robot before replacing parts

#### General

Follow the procedures in this section whenever breaking the paint of the robot during replacement of parts.

When replacing parts on a robot with protection type Foundry Prime, it is important to make sure that after the replacement, no surface without paint is exposed to the aggressive working environment.

#### Required equipment

Equipment	Spare parts	Note
Sealing compound	3HAC026759-001	Sikaflex 521 FC. Color white.
Tooling pin		Width 6-9 mm, made of wood.
Cleaning agent		Ethanol
Knife		
Lint free cloth		
Rust preventive		Mercasol
Brush		
Touch up paint Foundry Prime / Foundry Prime 2 / Foundry Prime 3	3HAC035355-001	Grey

#### Removing

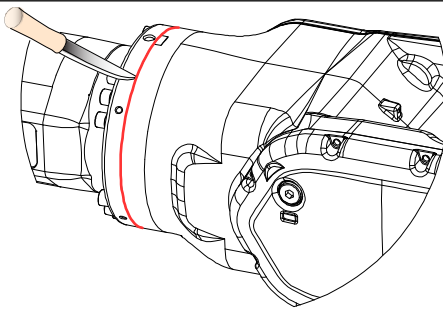
Action	Description
1 Cut the paint with a knife in the joint between the part that will be removed and the structure, to avoid that the paint cracks.	 xx0900000121
2 Carefully grind the paint edge that is left on the structure to a smooth surface.	



#### Refitting

Action	Description
1 Before the parts are refitted, clean the joint so that it is free from oil and grease.	Use ethanol on a lint free cloth.
2 Place the tooling pin in hot water.	

*Continues on next page*

## 4.2.4 Cut the paint or surface on the robot before replacing parts

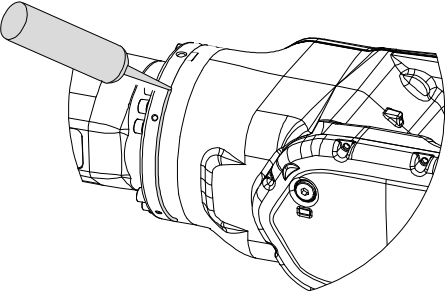
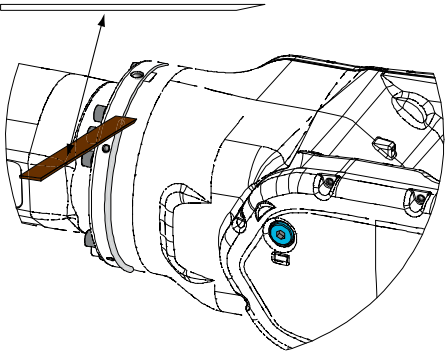
Continued

	Action	Description
3	Seal all refitted joints with sealing compound.	 <p>xx0900000122</p>
4	Use the tooling pin to even out the surface of the sealing compound.	 <p>xx0900000125</p>
5	<b>For robots with protection type Foundry Prime</b> Wait 10 minutes.	<b>For robots with protection type Foundry Prime</b> Sikaflex 521FC skin dry time (10 minutes).
6	Use Touch up paint Foundry Prime, grey to paint the joint.   <b>Note</b>  Always read the instruction in the product data sheet in the paint repair kit for Foundry Prime.	3HAC035355-001
7	Apply Mercasol on all screw heads and set screws after tightening.	

## 4 Repair

### 4.2.5 The brake release buttons may be jammed after service work

### 4.2.5 The brake release buttons may be jammed after service work

#### Description

The brake release unit has push-buttons for the brake release of each axis motor. When service work is performed inside the SMB recess that includes removal and refitting of the brake release unit, the brake release buttons may be jammed after refitting.



#### **DANGER**

If the power is turned on while a brake release button is jammed in depressed position, the affected motor brake is released. This may cause serious personal injuries and damage to the robot.

#### Elimination

To eliminate the danger after service work has been performed inside the SMB recess, follow the procedure below.

	Action
1	Make sure the power is turned off.
2	Remove the push-button guard, if necessary.
3	Verify that the push-buttons of the brake release unit are working by pressing them down, one by one. Make sure none of the buttons are jammed in the tube.
4	If a button gets jammed in the depressed position, the alignment of the brake release unit must be adjusted so that the buttons can move freely in their tubes.

## 4.3 Complete robot

### 4.3.1 Removing the complete cable harness

---

#### Introduction

This procedure describes how to remove the complete cable harness.

How to refit the cable harness is described in section [Refitting the complete cable harness on page 216](#).

The removal procedure is presented in the order the work is recommended to be performed. Therefore the order is different in the two procedures removal and refitting of the cable harness. Cross references will make it easy to find what is needed to know as the work continues.

The section *Removing the complete cable harness* consists of the following parts presented in the order the work is recommended to be performed:

- Removal in the *base* [Removing cable harness in base on page 206](#)
- Removal in the *frame* [Removing cable harness in frame on page 211](#)
- Removal in *lower arm* and *armhouse* [Removing cable harness in lower arm and armhouse on page 213](#).

How to replace the SMB unit, brake release unit and motors can be found in:

- SMB unit [Removing the SMB unit on page 246](#)
- Brake release unit [Removing the brake release board on page 252](#)
- Motors [Removing motors on page 304](#)

*Continues on next page*

## 4 Repair

### 4.3.1 Removing the complete cable harness

*Continued*

#### Location of the cable harness

The location of the cable harness in the base, frame and lower arm is shown in the figures.

Cable harness, base and frame.

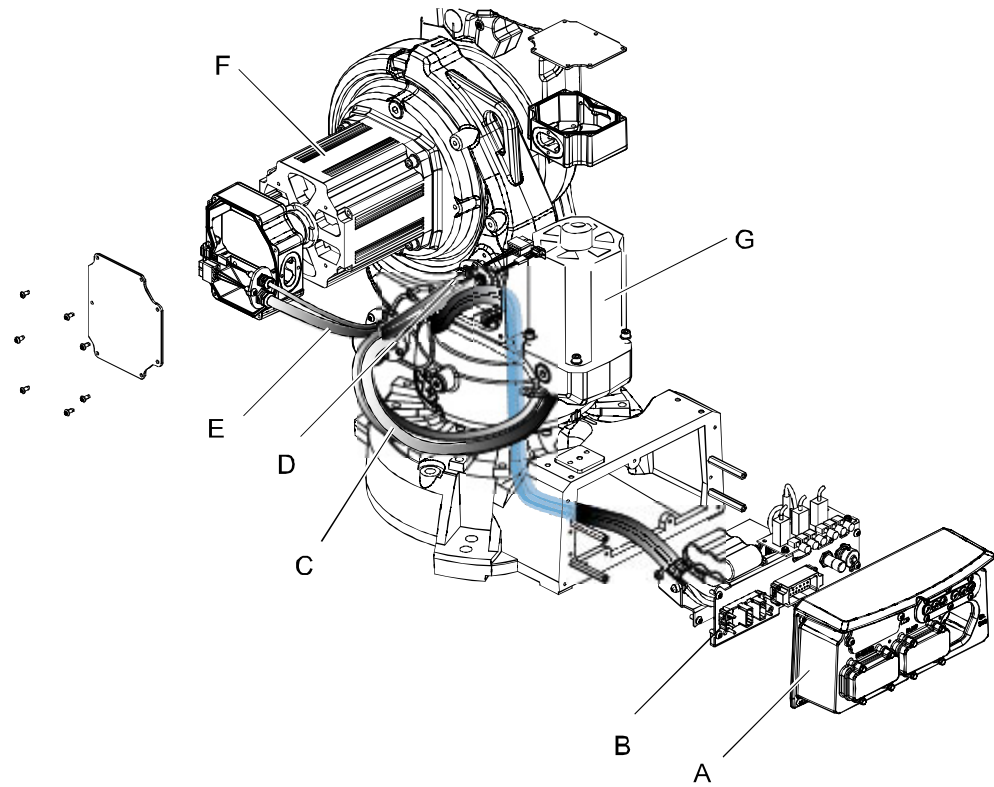

xx090000009

A	Cover base
B	Bracket
C	Cable harness
D	Axis-1 motor cable
E	Axis-2 motor cable
F	Axis-2 motor
G	Axis-1 motor

*Continues on next page*



Cable harness, lower arm.

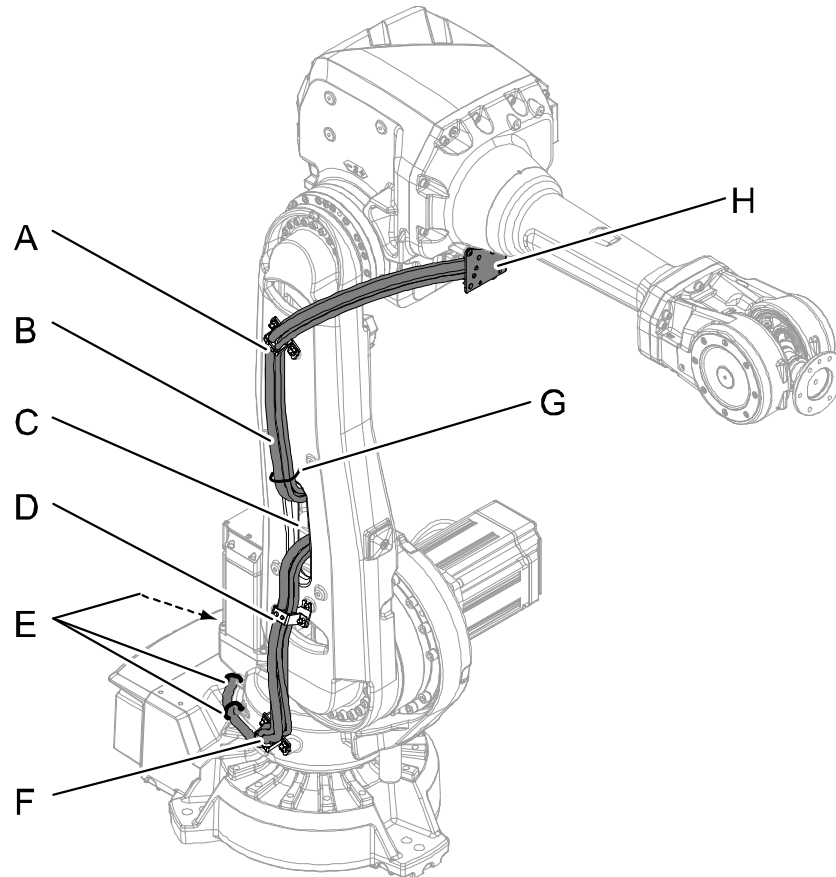

xx090000012

A	Bracket, lower arm
B	Cable harness
C	Hole in lower arm
D	Bracket, lower arm
E	Cable straps, one not visible here (steel)
F	Bracket, frame
G	Cable strap, lower arm (plastic)
H	Bracket, armhouse

**Required equipment**

Equipment	Note
Deep well hexagon socket	Width 30 mm
Standard toolkit	Content is defined in section <a href="#">Standard tools on page 398</a> .
Other tools and procedures may be required. See references to these procedures in the step-by-step instructions below.	These procedures include references to the tools required.

Continues on next page

## 4 Repair

### 4.3.1 Removing the complete cable harness

*Continued*

#### Additional equipment - Foundry Prime

Equipment	Art. no.	Note
Rust preventive	3HAC034903-001	Mercasol
Sikaflex 521FC	3HAC026759-001	
Loctite 574	12340011-116	
Brush		
Foundry Prime touch up kit	3HAC035355-001	

#### Deciding calibration routine

Decide which calibration routine to be used, based on the information in the table. Depending on which routine is chosen, action might be required prior to beginning the repair work of the robot, see the table.





	Action	Note
1	Decide which calibration routine to use for calibrating the robot. <ul style="list-style-type: none"><li>Reference calibration. External cable packages (DressPack) and tools can stay fitted on the robot.</li><li>Fine calibration. All external cable packages (DressPack) and tools must be removed from the robot.</li></ul>	
	<b>If the robot is to be calibrated with reference calibration:</b> Find previous reference values for the axis or create new reference values. These values are to be used after the repair procedure is completed, for calibration of the robot. If no previous reference values exist, and no new reference values can be created, then reference calibration is not possible.	Follow the instructions given in the reference calibration routine on the FlexPendant to create reference values. Creating new values requires possibility to move the robot. Read more about reference calibration for Axis Calibration in <a href="#">Reference calibration routine on page 368</a> . Read more about reference calibration for Pendulum Calibration in <i>Operating manual - Calibration Pendulum</i> .
	<b>If the robot is to be calibrated with fine calibration:</b> Remove all external cable packages (DressPack) and tools from the robot.	

#### Removing cable harness in base

Use this procedure to remove the cable harness in the base.

	Action	Note
1	Decide which calibration routine to use, and take actions accordingly prior to beginning the repair procedure.	

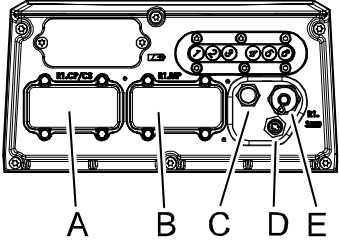
*Continues on next page*

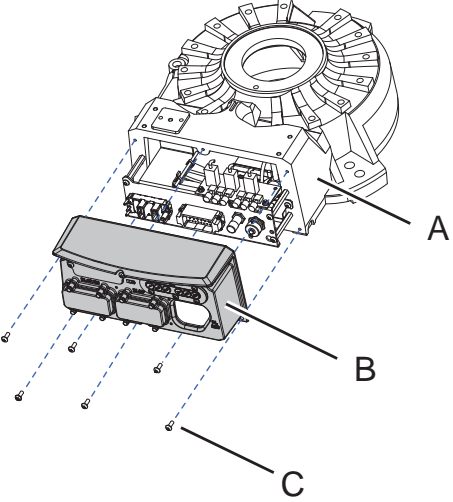

	Action	Note
2	<p> <b>DANGER</b></p> <p>Turn off all:</p> <ul style="list-style-type: none"> <li>• electric power supply</li> <li>• hydraulic pressure supply</li> </ul> <p>to the robot, before entering the robot working area.</p>	
3	<p>Disconnect the following connectors on the <i>base cover</i>:</p> <ul style="list-style-type: none"> <li>• R1.CP/CS</li> <li>• R1.MP</li> <li>• R1.ETHERNET (if used)</li> </ul> <p> <b>Tip</b></p> <p>Do not remove the <i>R1.SMB-connector</i> and <i>air hose connector</i> at this stage. It will be easier to remove these two when the cover base has been removed.</p>	 <p>xx0900000014</p> <p><b>Parts:</b></p> <ul style="list-style-type: none"> <li>• A: R1.CP/CS</li> <li>• B: R1.MP</li> <li>• C: Air hose connector</li> <li>• D: Position of R1.ETHERNET (if used)</li> <li>• E: R1.SMB</li> </ul>
4	<p> <b>CAUTION</b></p> <p>Always cut the paint with a knife and grind the paint edge when disassembling parts. See <a href="#">Cut the paint or surface on the robot before replacing parts on page 200</a>.</p>	
5	<p>Remove the <i>cover base</i>.</p>	 <p>xx0800000456</p> <ul style="list-style-type: none"> <li>A Base</li> <li>B Cover base</li> <li>C Attachment screws</li> </ul>

Continues on next page

## 4 Repair

### 4.3.1 Removing the complete cable harness

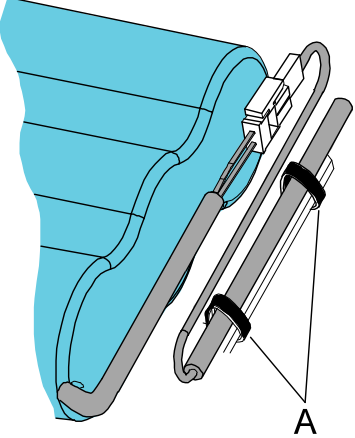
Continued

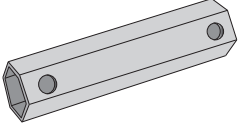
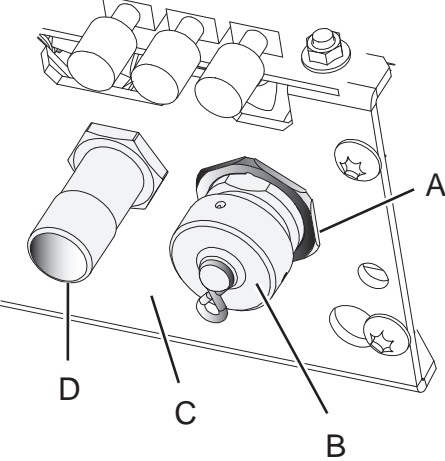
	Action	Note
6	Disconnect connectors on the brake release unit: <ul style="list-style-type: none"> <li>• X8</li> <li>• X9</li> <li>• X10</li> </ul>	
7	Cut the <i>cable straps</i> securing the battery cable.	 <p>xx0900000099</p> <p>Parts:</p> <ul style="list-style-type: none"> <li>• A: Cable straps (2 pcs)</li> </ul>
8	Disconnect the battery cable.	
9	Unscrew the thin nut securing the R1.SMB connector on the outside of the bracket.   <b>Tip</b> Use a deep well hexagon socket, width 30 mm (like the ones used for spark plugs, or similar).   <p>xx1200000888</p>	 <p>xx1200000889</p> <p>A Thin nut, width 30 mm            B R1.SMB            C Bracket            D Air connector</p>
10	Unscrew the nut for the air connection on the inside of the bracket.	

Continues on next page

Action	Note
11	<p>Remove the screw that secures the bracket and unscrew the three other screws a little just enough to be able to slide the bracket sideways.</p>
12	<p>Remove the <i>bracket</i> by sliding it off the remaining three attachment screws and put it at a 90° angle from the base.</p> <p>Putting the bracket at a 90° angle facilitates the disconnecting of cables from the bracket.</p> <p> <b>Note</b></p> <p>Use caution when performing this procedure in order not to damage cables or other components!</p>
13	<p>Remove connectors and air hose connector completely from the <i>bracket</i>:</p> <ul style="list-style-type: none"> <li>• R1.CP/CS</li> <li>• R1.MP</li> <li>• R1.SMB</li> <li>• Air hose connector</li> <li>• R1.ETHERNET (if used)</li> </ul>
14	<p>Remove the <i>SMB unit</i> from its attachment screws.</p> <p>Leave the screws in the base.</p>

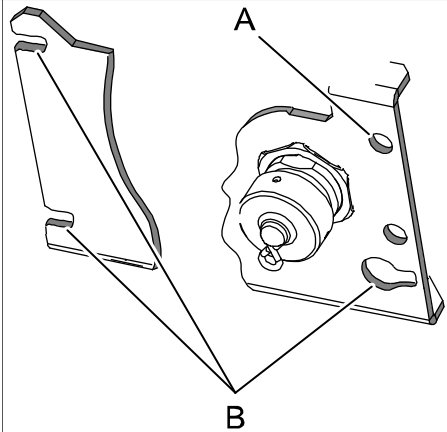

xx0900000100

Parts:

- A: Screw to be removed
- B: Screws to be unscrewed (3 pcs)

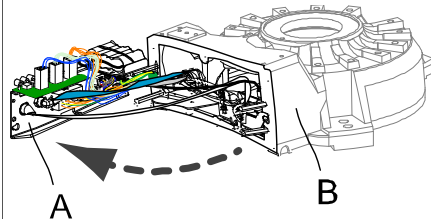

xx0900000013

Parts:

- A: Bracket at a 90° angle
- B: Base

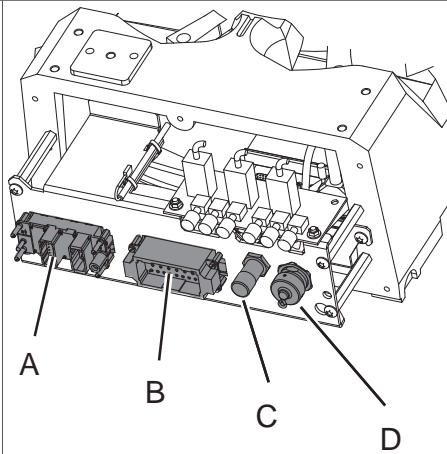

xx1200000890

- A R1.CP/CS
- B R1.MP
- C Air hose connector
- D R1.SMB

How to remove the *SMB unit* is described in section:

- [Removing the SMB unit on page 246](#)

Continues on next page

## 4 Repair

### 4.3.1 Removing the complete cable harness

*Continued*

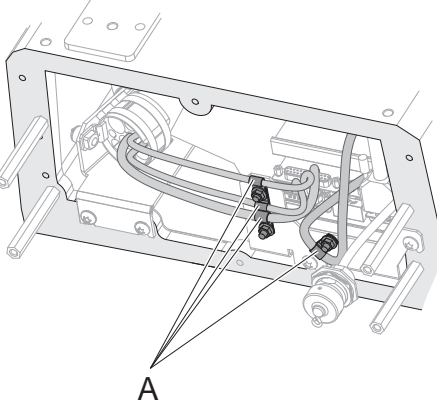
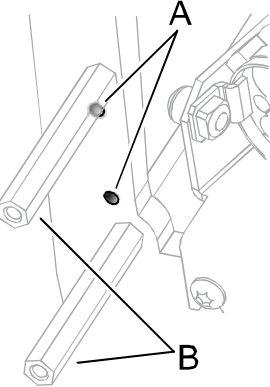
	Action	Note
15	Disconnect connectors on the SMB unit: <ul style="list-style-type: none"><li>• R1.SMB1-2</li><li>• R1.SMB2-6</li><li>• R2.SMB</li></ul>	
16	Disconnect the <i>screen connections</i> of: <ul style="list-style-type: none"><li>• R1.SMB1-2</li><li>• R1.SMB2-6</li></ul>	 <p data-bbox="962 869 1062 887">xx0900000035</p> <p data-bbox="962 909 1023 927">Parts:</p> <ul data-bbox="991 936 1350 958" style="list-style-type: none"><li>• A: Screen connection (4 pcs)</li></ul>
17	Disconnect the <i>earth cables</i> .	 <p data-bbox="962 1368 1062 1386">xx0900000015</p> <p data-bbox="962 1408 1023 1426">Parts:</p> <ul data-bbox="991 1435 1241 1489" style="list-style-type: none"><li>• A: Earth</li><li>• B: Distance screws</li></ul>

*Continues on next page*

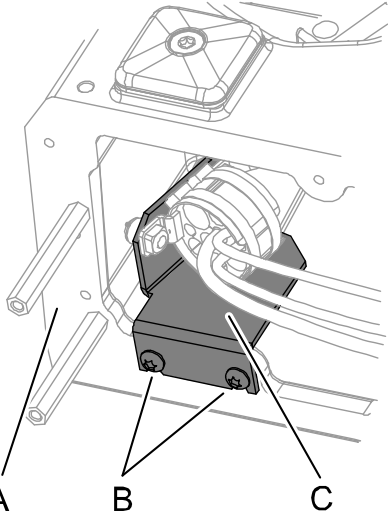
	Action	Note
18	Remove the <i>bracket</i> securing the cable package inside the base on the left side, by following these steps: <ul style="list-style-type: none"> <li>• Unscrew the attachment screws just enough to be able to remove the bracket.</li> <li>• Lift the bracket off the screws.</li> </ul>	 <p>xx0900000018</p> <p>Parts:</p> <ul style="list-style-type: none"> <li>• A: Base</li> <li>• B: Attachment screws</li> <li>• C: Bracket</li> </ul>
19	Continue removal of the cable package from the frame.	How to remove the cable package from the frame is described in section <ul style="list-style-type: none"> <li>• <a href="#">Removing cable harness in frame on page 211</a></li> </ul>

Removing cable harness in frame

Use this procedure to remove the cable harness in the frame.



Tip

Before starting this procedure, first remove the cable harness in the base. See [Removing the complete cable harness on page 203](#).





	Action	Note
1	 <p><b>DANGER</b></p> Turn off all: <ul style="list-style-type: none"> <li>• electric power supply</li> <li>• hydraulic pressure supply</li> </ul> to the robot, before entering the robot working area.	
2	Disconnect the <i>motor cables</i> on the axis-1 and axis-2 motors.	How to remove the motor cables is described in section: <ul style="list-style-type: none"> <li>• <a href="#">Removing motors on page 304</a></li> </ul>

Continues on next page

## 4 Repair

### 4.3.1 Removing the complete cable harness

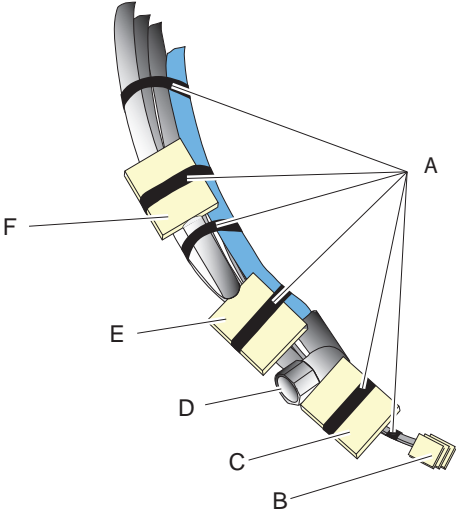
Continued

	Action	Note
3	<p> <b>CAUTION</b></p> <p>Always cut the paint with a knife and grind the paint edge when disassembling parts. See <a href="#">Cut the paint or surface on the robot before replacing parts on page 200</a>.</p>	
4	Remove the <i>bracket</i> securing the cable package to the frame.	See the figure in: <ul style="list-style-type: none"> <li><a href="#">Location of the cable harness on page 204</a></li> </ul>
5	Cut the <i>cable straps</i> securing the cable harness to the frame and lower arm.	See the figure in: <ul style="list-style-type: none"> <li><a href="#">Location of the cable harness on page 204</a></li> </ul>
6	<p>Prepare the end of the cable package in the base with tape as shown in the figure.</p> <p> <b>Tip</b></p> <p>In order to protect the connectors from getting residual grease on the cable harness, put some plastic over them prior to pushing it through the hole in the frame.</p>	 <p>xx1200000886</p> <p>A Tape  B Connectors to SMB unit and Brake release unit  C R1.CP/CS  D Air hose  E R1.MP  F R1.SMB (Connector bent and taped upwards)</p>
7	<p>Pull out the cable package through the hole in the frame.</p> <p> <b>Note</b></p> <p>Use caution when performing this procedure in order not to damage cables or other components!</p>	
8	Continue the removal of the cable package from the lower arm and armhouse.	How to remove the cable package from the lower arm and armhouse is described in section: <ul style="list-style-type: none"> <li><a href="#">Removing cable harness in lower arm and armhouse on page 213</a></li> </ul>

Continues on next page





### Removing cable harness in lower arm and armhouse

Use this procedure to remove the cable harness in the lower arm and armhouse.



#### Tip

Before starting this procedure, first remove the cable harness in the base [Removing the complete cable harness on page 203](#) and frame [Removing the complete cable harness on page 203](#).

	Action	Note
1	 <b>DANGER</b> Turn off all: <ul style="list-style-type: none"> <li>• electric power supply</li> <li>• hydraulic pressure supply</li> </ul> to the robot, before entering the robot working area.	
2	Cut the <i>cable strap</i> on the lower arm.	See the figure in: <ul style="list-style-type: none"> <li>• <a href="#">Location of the cable harness on page 204</a> (Cable harness, lower arm)</li> </ul>
3	 <b>CAUTION</b> Always cut the paint with a knife and grind the paint edge when disassembling parts. See <a href="#">Cut the paint or surface on the robot before replacing parts on page 200</a> .	

Continues on next page

## 4 Repair

### 4.3.1 Removing the complete cable harness

Continued

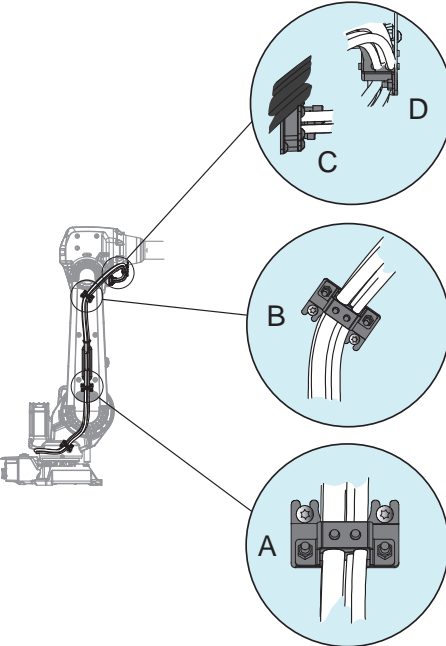
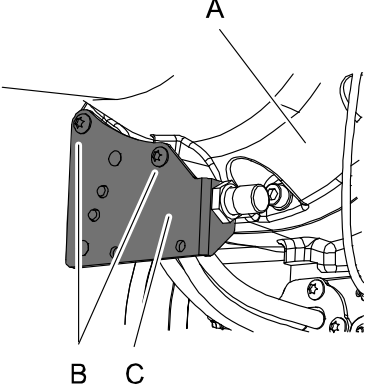
	Action	Note
4	Remove the <i>brackets</i> on the lower arm.	 <p>xx0900000020</p> <p><b>Parts:</b></p> <ul style="list-style-type: none"><li>• A: Bracket, lower arm</li><li>• B: Bracket, lower arm</li><li>• C: Bracket, armhouse</li><li>• D: Cable bracket</li></ul>
5	Remove the <i>bracket</i> on the armhouse.	 <p>xx0800000335</p> <p><b>Parts:</b></p> <ul style="list-style-type: none"><li>• A: Tubular shaft unit</li><li>• B: Attachment screws</li><li>• C: Bracket, armhouse</li></ul>

Continues on next page

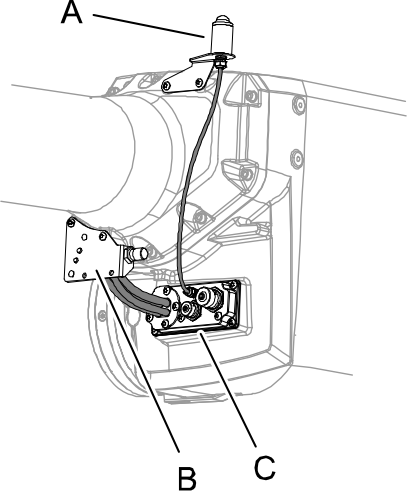
	Action	Note
6	Remove the <i>cable cover</i> on the armhouse.	 <p data-bbox="986 808 1090 826">xx080000338</p> <p data-bbox="986 846 1050 869">Parts:</p> <ul data-bbox="1018 875 1345 965" style="list-style-type: none"> <li>• A: Signal lamp</li> <li>• B: Bracket</li> <li>• C: Cable cover, armhouse</li> </ul>
7	Remove signal lamp if used.	
8	Continue the removal of the cable package by disconnecting the motor cables of the axis-3, axis-4, axis-5 and axis-6 motors.	<p data-bbox="986 1025 1439 1106">How to remove the <i>motor cables</i> from the <i>axis-3</i>, <i>axis-4</i>, <i>axis-5</i> and <i>axis-6</i> motors see section:</p> <ul data-bbox="1018 1106 1396 1133" style="list-style-type: none"> <li>• <a href="#">Removing motors on page 304</a></li> </ul>

## 4 Repair

---

### 4.3.2 Refitting the complete cable harness

### 4.3.2 Refitting the complete cable harness

---

#### Introduction

This procedure describes how to refit the complete cable harness.

How to remove the cable harness is described in [Removing the complete cable harness on page 203](#).

The refitting procedure is presented in the order the work is recommended to be performed.

Therefore the order is different in the two procedures removal and refitting of the cable harness. Cross references will make it easy to find what is needed to know as the work continues.

The section *Refitting the complete cable harness* consists of the following parts presented in the order the work is recommended to be performed:

- Refitting in the frame [Refitting the cable harness in the frame on page 219](#)
- Refitting in the base [Refitting the cable harness in the base on page 223](#)
- Refitting in the lower arm and armhouse [Refitting the cable harness in the lower arm and armhouse on page 229](#).

How to refit the SMB unit, brake release unit and motors can be found in:

- SMB unit [Refitting the SMB unit on page 248](#)
- Brake release unit [Refitting the brake release board on page 254](#)
- Motors [Refitting motors on page 313](#)

*Continues on next page*

**Location of the cable harness**

The location of the cable harness in the base, frame and lower arm is shown in the figures.

Cable harness, base and frame.

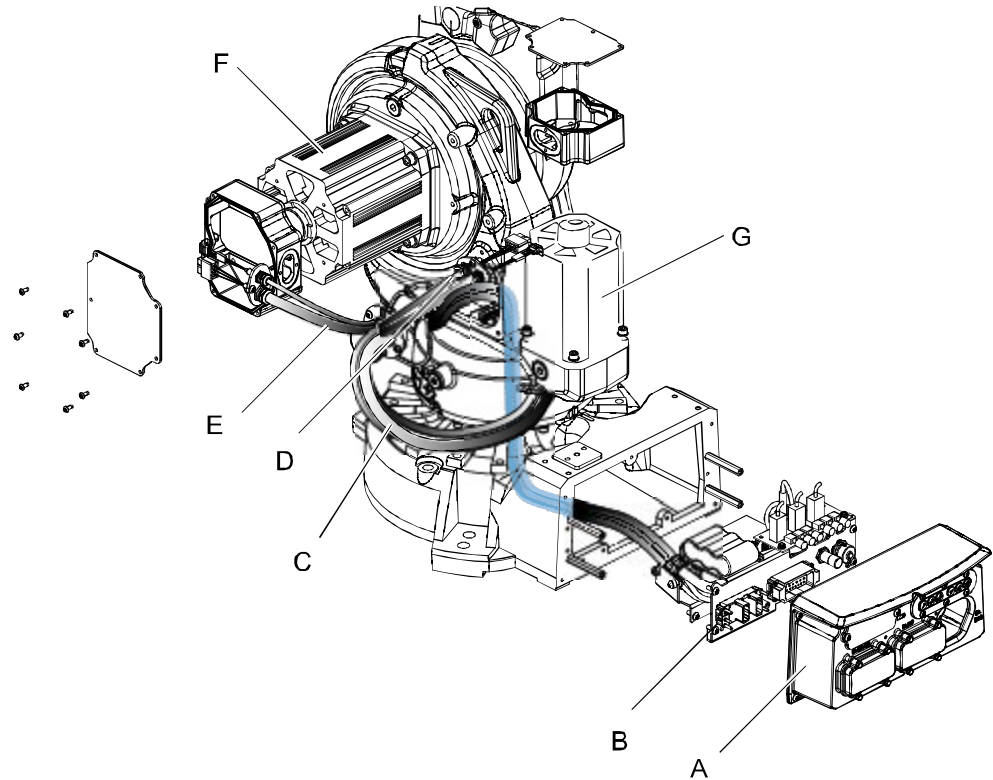

xx090000009

A	Cover base
B	Bracket
C	Cable harness
D	Axis-1 motor cable
E	Axis-2 motor cable
F	Axis-2 motor
G	Axis-1 motor

*Continues on next page*

## 4 Repair

### 4.3.2 Refitting the complete cable harness

Continued

Cable harness, lower arm.

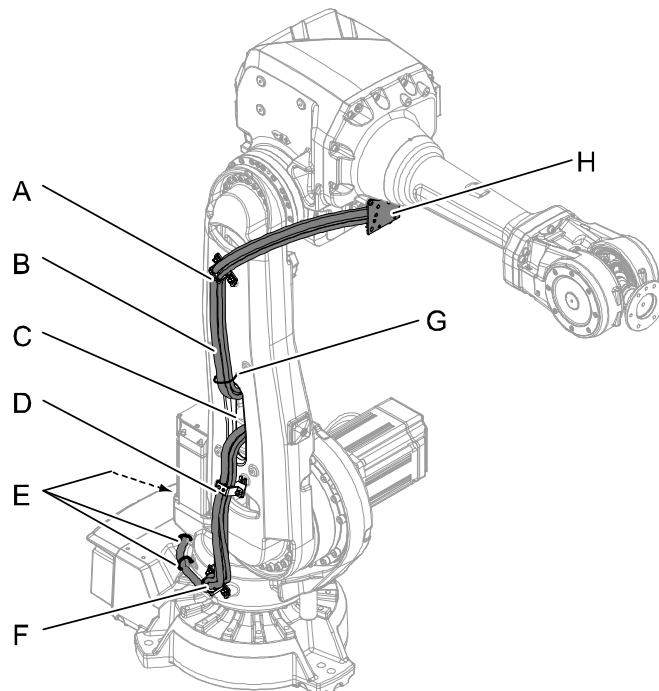

xx0900000012

A	Bracket, lower arm
B	Cable harness
C	Hole in lower arm
D	Bracket, lower arm
E	Cable straps, one not visible here (steel)
F	Bracket, frame
G	Cable strap, lower arm (plastic)
H	Bracket, armhouse

#### Required equipment

Equipment	Note
Deep well hexagon socket	Width 30 mm
Standard toolkit	Content is defined in section <a href="#">Standard tools on page 398</a> .
Other tools and procedures may be required. See references to these procedures in the step-by-step instructions below.	These procedures include references to the tools required.
Cable grease	3HAC042536-001 (Shell Gadus S2)

#### Additional equipment - Foundry Prime

Equipment	Art. no.	Note
Rust preventive	3HAC034903-001	Mercasol

Continues on next page

Equipment	Art. no.	Note
Sikaflex 521FC	3HAC026759-001	
Loctite 574	12340011-116	
Brush		
Foundry Prime touch up kit	3HAC035355-001	

**CAUTION**

Always cut the paint with a knife and grind the paint edge when disassembling parts. See [Cut the paint or surface on the robot before replacing parts on page 200](#).

**Refitting the cable harness in the frame**

Use this procedure to refit the cable harness in the frame.



	Action	Note
1	<b>DANGER</b> Turn off all: <ul style="list-style-type: none"> <li>• electric power supply</li> <li>• hydraulic pressure supply</li> </ul> to the robot, before entering the robot working area.	
2	Clean the joints that have been opened. See <a href="#">Cut the paint or surface on the robot before replacing parts on page 200</a>	
3	Apply <b>cable grease</b> on these surfaces: <ul style="list-style-type: none"> <li>• cable guide inside the hole</li> <li>• the part of the cable harness that runs through the cable guide.</li> </ul>	Cable grease is specified in: <ul style="list-style-type: none"> <li>• <a href="#">Required equipment on page 218</a></li> </ul>
4	<b>Note</b> Two alternative methods to insert the cable package in frame and base are presented below. Chose one of the methods.	

Continues on next page

## 4 Repair



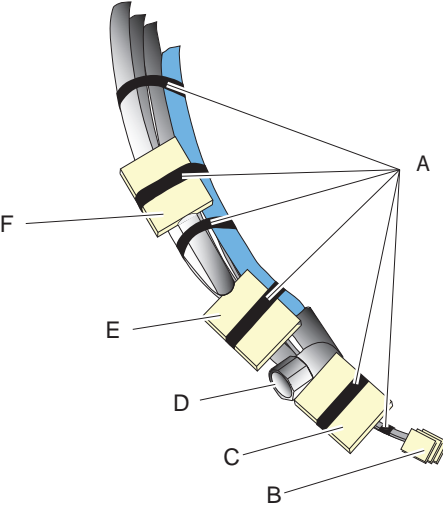

### 4.3.2 Refitting the complete cable harness

Continued

	Action	Note
5	<p>Use this procedure when replacing the old cable harness:</p> <p><b>Method 1, step 1:</b></p> <p>Prepare the end of the cable package in the base with tape as shown in the figure.</p> <p> <b>Tip</b></p> <p>In order to protect the connectors from getting residual grease on the cable harness, put some plastic over them prior to pushing it through the hole in the frame.</p>	 <p>xx1200000886</p> <ul style="list-style-type: none"> <li>A Tape</li> <li>B Connectors to SMB unit and Brake release unit</li> <li>C R1.CP/CS</li> <li>D Air hose</li> <li>E R1.MP</li> <li>F R1.SMB (Connector bent and taped upwards)</li> </ul>
6	<p>Use this procedure when replacing the old cable harness:</p> <p><b>Method 1, step 2:</b></p> <p>Push the cable package carefully in through the base and up through the hole in the frame.</p> <p> <b>Note</b></p> <p>Use caution when performing this procedure in order not to damage cables or other components!</p>	

Continues on next page



	Action	Note
7	<p><i>Use this procedure when replacing the old cable harness:</i></p> <p><b>Method 2:</b></p> <p>Push the cable harness carefully into the hole in the frame and out of the hole in the base.</p> <p>Perform the procedure in the following order:</p> <ul style="list-style-type: none"> <li>• R1.MP</li> <li>• R1.CP/CS</li> <li>• R1.SMB1-2 and R1.SMB3-6</li> <li>• Air hose.</li> </ul> <p> <b>Note</b></p> <p>Use caution when performing this procedure in order not to damage cables or other components!</p> <p> <b>Tip</b></p> <p>In order to protect the connectors from getting residual grease on the cable harness, put some plastic over them prior to pushing it through the hole in the frame.</p>	
8	<p><i>Use this procedure when fitting a new cable harness:</i></p> <p>Without removing the plastic around cables and hose, push the cable harness through the hole in the frame.</p> <p> <b>Note</b></p> <p>Use caution when performing this procedure in order not to damage cables or other components!</p>	<p> <b>Note</b></p> <p>Check that cables and air hose are placed as shown in the figure above.</p>

Continues on next page

## 4 Repair

### 4.3.2 Refitting the complete cable harness

Continued

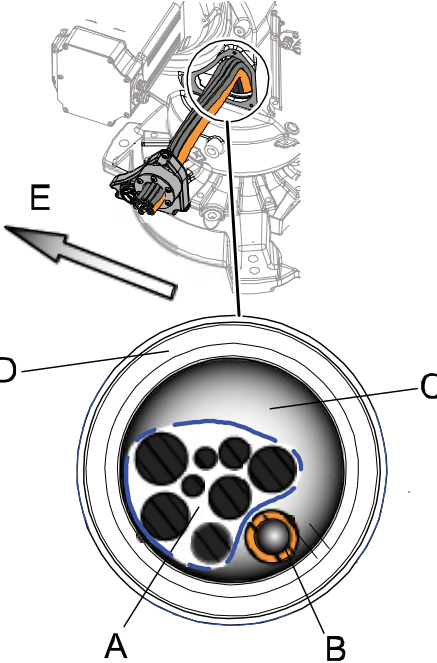
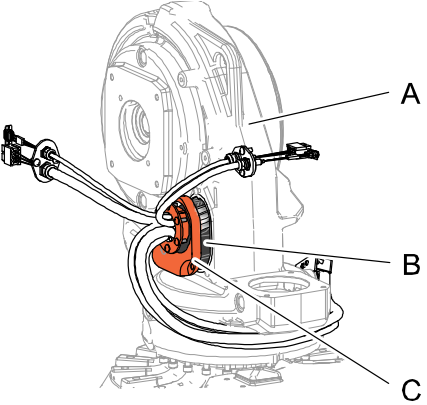
	Action	Note
9	<p> <b>Note</b></p> <p>It is vital that the position of the air hose is correct, as shown in the figure!</p>	 <p>xx0900000096</p> <p><b>Parts:</b></p> <ul style="list-style-type: none"> <li>• A: Cables</li> <li>• B: Air hose</li> <li>• C: Hole in frame</li> <li>• D: Cable guide</li> <li>• E: Position of the front of the robot</li> </ul>
10	<p>Secure the <i>cover</i> to the frame with its attachment screws.</p>	 <p>xx0900000016</p> <p><b>Parts:</b></p> <ul style="list-style-type: none"> <li>• A: Frame</li> <li>• B: Hole in frame</li> <li>• C: Cover</li> </ul>
11	<p>Connect the axis-1 and axis-2 motor cables.</p>	<p>How to refit the motor cables is described in section:</p> <ul style="list-style-type: none"> <li>• <a href="#">Refitting motors on page 313</a></li> </ul>

Continues on next page

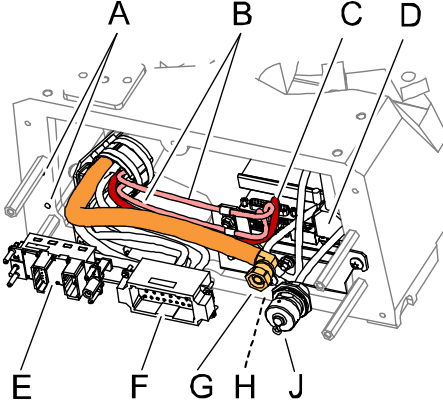
	Action	Note
12	Sort out the different cables the way they later will be fit on the bracket in the base.	 <p>xx0900000017</p> <p>Connections:</p> <ul style="list-style-type: none"> <li>• A: Earth cables</li> <li>• B: R1.SMB1-2</li> <li>• C: R1.SMB3-6</li> <li>• D: R2.SMB</li> <li>• E: R1.CP/CS</li> <li>• F: R1.MP</li> <li>• G: Air hose</li> <li>• H: Position of R1.ETHERNET (if used)</li> <li>• J: R1.SMB</li> </ul>
13	Continue the refitting of the cable harness in the base.	How to refit the cable harness in the base is described in section: <ul style="list-style-type: none"> <li>• <a href="#">Refitting the cable harness in the base on page 223</a></li> </ul>

**Refitting the cable harness in the base**

Use this procedure to refit the cable harness in the base.

 **Tip**

Before starting this procedure, first refit the cable harness in the *frame*. See:

- [Refitting the complete cable harness on page 216](#)



	Action	Note
1	 <b>DANGER</b> Turn off all: <ul style="list-style-type: none"> <li>• electric power supply</li> <li>• hydraulic pressure supply</li> </ul> to the robot, before entering the safe-guarded space.	

Continues on next page

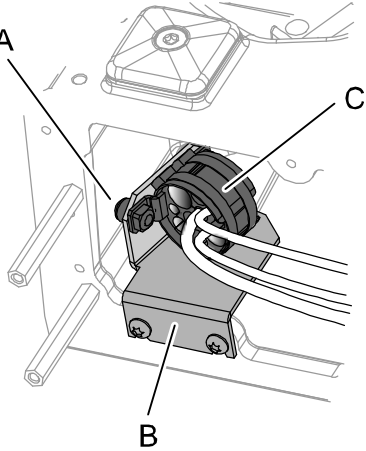

## 4 Repair

### 4.3.2 Refitting the complete cable harness

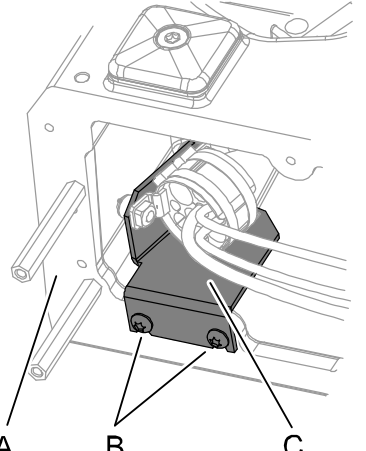
Continued

	Action	Note
2	Attach the <i>cable harness</i> to the bracket.	 <p>xx0900000098</p> <p>Parts:</p> <ul style="list-style-type: none"><li>• A: Attachment screw and nut</li><li>• B: Bracket</li><li>• C: Cable harness</li></ul>
3	<p>Secure the <i>bracket</i> on its <i>attachment screws</i> in the base.</p> <p> <b>Tip</b></p> <p>Perform this in the following order:</p> <ul style="list-style-type: none"><li>• Put the <i>attachment screws</i> in the holes but do not tighten them yet (if they have been removed earlier).</li><li>• Place the <i>bracket</i> on the attachment screws.</li><li>• Secure the bracket with its attachment screws.</li></ul>	 <p>xx0900000018</p> <p>Parts:</p> <ul style="list-style-type: none"><li>• A: Base</li><li>• B: Attachment screws (2 pcs)</li><li>• C: Bracket</li></ul>

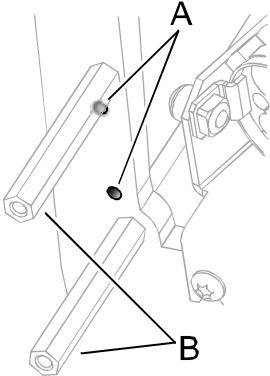
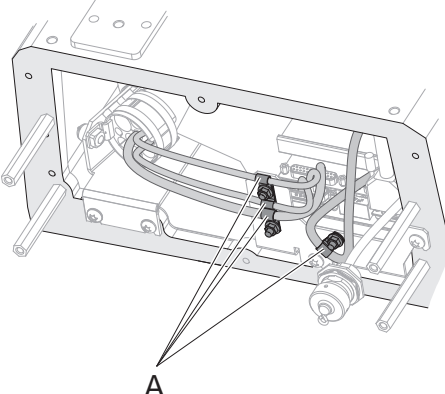
Continues on next page

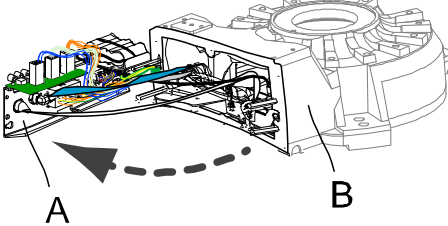

	Action	Note
4	Refit the <i>earth cables</i> .	 <p>xx0900000015</p> <p>Parts:</p> <ul style="list-style-type: none"> <li>• A: Earth</li> <li>• B: Distance screws</li> </ul>
5	Connect the contacts on the SMB unit: <ul style="list-style-type: none"> <li>• R1.SMB1-2</li> <li>• R1.SMB3-6</li> <li>• R2.SMB</li> </ul>	
6	Refit the SMB unit.	How to refit the SMB unit is described in section: <ul style="list-style-type: none"> <li>• <a href="#">Refitting the SMB unit on page 248</a></li> </ul>
7	Refit the cables with the <i>screen connections</i> .	 <p>xx0900000035</p> <p>Parts:</p> <ul style="list-style-type: none"> <li>• A: Screen connections (4 pcs)</li> </ul>
8	 <b>Tip</b> When refitting connectors on the <i>bracket</i> , put it at a 90° angle.	 <p>xx0900000013</p> <p>Parts:</p> <ul style="list-style-type: none"> <li>• A: Bracket</li> <li>• B: Base</li> </ul>

Continues on next page



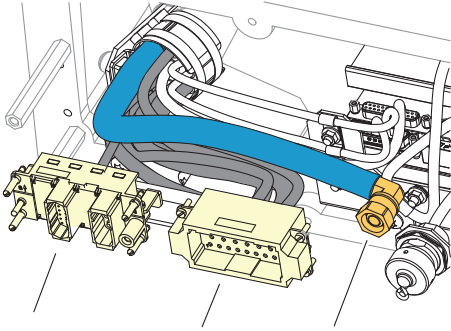

## 4 Repair

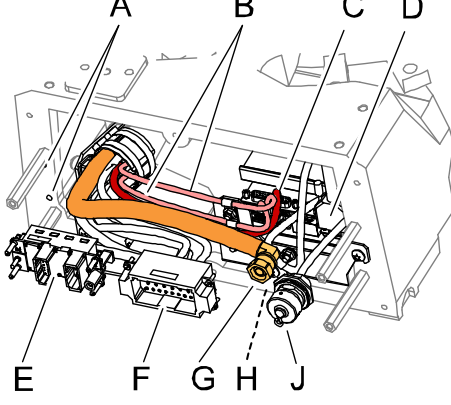
### 4.3.2 Refitting the complete cable harness

Continued

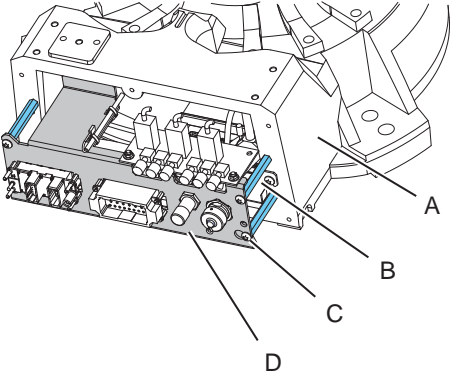
	Action	Note
9	<p>Before refitting the connectors on the bracket, arrange cables and connectors as shown in the figure.</p>	 <p>xx1200000857</p> <ul style="list-style-type: none"> <li>A R1.CP/CS</li> <li>B R1.MP</li> <li>C Air hose</li> </ul>
10	<p>Refit the <i>connectors</i> and <i>air hose</i> on the bracket:</p> <ul style="list-style-type: none"> <li>• R1.CP/CS</li> <li>• R1.ETHERNET (if used)</li> <li>• R1.MP</li> </ul> <p> <b>Tip</b></p> <p>Do not refit the <i>R1.SMB-connector</i> and <i>air hose</i> at this stage. It will be easier to refit these two when the bracket has been fitted to the distance screws.</p>	 <p>xx0900000017</p> <p>Connectors:</p> <ul style="list-style-type: none"> <li>• A: Earth cables</li> <li>• B: R1.SMB1-2</li> <li>• C: R1.SMB3-6</li> <li>• D: R2.SMB</li> <li>• E: R1.CP/CS</li> <li>• F: R1.MP</li> <li>• G: Air hose</li> <li>• H: Position of R1.ETHERNET (if used)</li> <li>• J: R1.SMB</li> </ul>

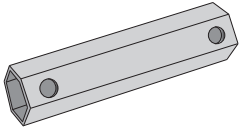
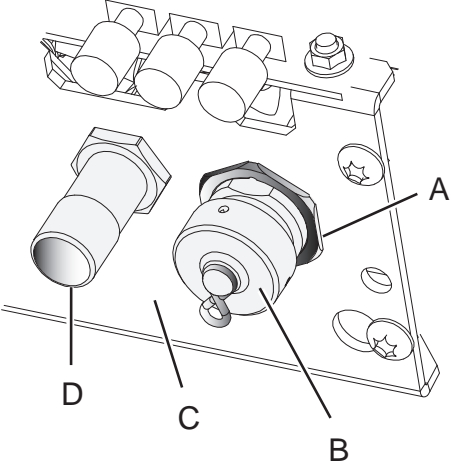
Continues on next page

	Action	Note
11	Secure the bracket on the distance screws.	 <p>xx1200000887</p> <p>A Base B Distance screw C Attachment screw D Bracket</p>
12	Reconnect connectors on the brake release unit: <ul style="list-style-type: none"> <li>• X8</li> <li>• X9</li> <li>• X10</li> </ul>	
13	Refit the <i>R1.SMB-connector</i> on the bracket.   <b>Tip</b> Use a deep well hexagon socket, width 30 mm (like the ones used for spark plugs, or similar).   xx1200000888	 <p>xx1200000889</p> <p>A Thin nut, width 30 mm B R1.SMB C Bracket D Air connector</p>
14	Refit the <i>air hose connector</i> on the bracket.   <b>Note</b> Check that there is no leakage from the air hose.	
15	Reconnect the battery cable.	

Continues on next page

## 4 Repair

### 4.3.2 Refitting the complete cable harness

Continued

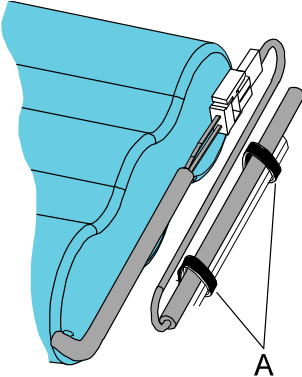
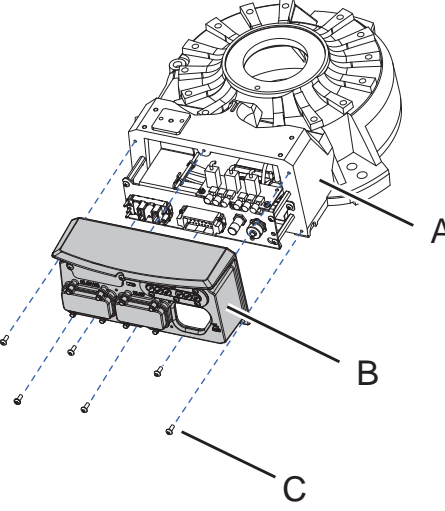
	Action	Note
16	Secure the battery cable with <i>cable straps</i> .	 <p>xx0900000099</p> <p>Parts:</p> <ul style="list-style-type: none"> <li>A: Cable straps (2 pcs)</li> </ul>
17	Use caution when pushing the <i>base cover</i> into position while at the same time checking that no cables are damaged.	 <p>xx0800000456</p> <p>Parts:</p> <ul style="list-style-type: none"> <li>A: Base</li> <li>B: Base cover</li> <li>C: Attachment screws (6 pcs)</li> </ul>
18	Secure the <i>base cover</i> with its attachment screws.	
19	Refit the <i>bracket</i> on the frame.	See the figure in: <ul style="list-style-type: none"> <li><a href="#">Location of the cable harness on page 217</a></li> </ul>
20	Refit the <i>cable straps</i> securing the cable harness to the frame.	See the figure in: <ul style="list-style-type: none"> <li><a href="#">Location of the cable harness on page 217</a></li> </ul>
21	Continue the refitting of the cable package on lower arm and armhouse.	How to refit the cable harness on the <i>lower arm and armhouse</i> is described in section: <ul style="list-style-type: none"> <li><a href="#">Refitting the cable harness in the lower arm and armhouse on page 229</a></li> </ul>

Continues on next page



Refitting the cable harness in the lower arm and armhouse

Use this procedure to refit the cable harness in the *lower arm* and *armhouse*.



Tip

Before starting this procedure, first refit the cable harness in the *frame* and *base*.  
See:

- [Refitting the complete cable harness on page 216](#)
- [Refitting the complete cable harness on page 216](#)

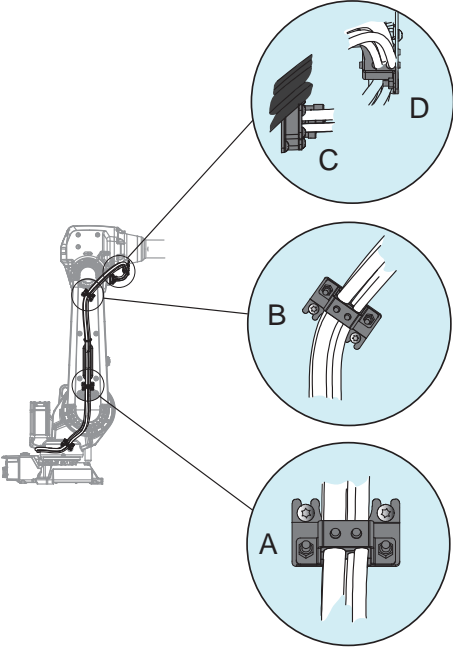
	Action	Note
1	 <b>DANGER</b> Turn off all: <ul style="list-style-type: none"> <li>• electric power supply</li> <li>• hydraulic pressure supply</li> </ul> to the robot, before entering the robot working area.	
2	Secure the <i>brackets</i> on the lower arm.	 <p>xx0900000020</p> <p>Parts:</p> <ul style="list-style-type: none"> <li>• A: Bracket, lower arm</li> <li>• B: Bracket, lower arm</li> <li>• C: Bracket, armhouse</li> <li>• D: Cable bracket</li> </ul>
3	Refit the <i>cable straps</i> securing the cable harness to the lower arm.	See the figure in: <ul style="list-style-type: none"> <li>• <a href="#">Location of the cable harness on page 217</a> (Cable harness, lower arm)</li> </ul>
4	Push the cable harness carefully into the armhouse.	

Continues on next page



## 4 Repair

### 4.3.2 Refitting the complete cable harness

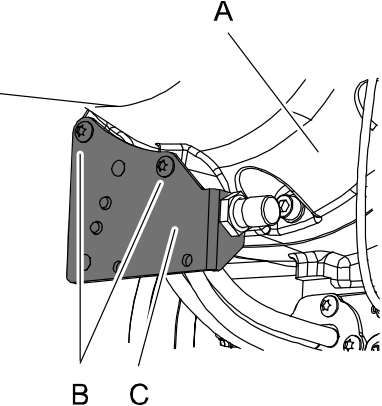
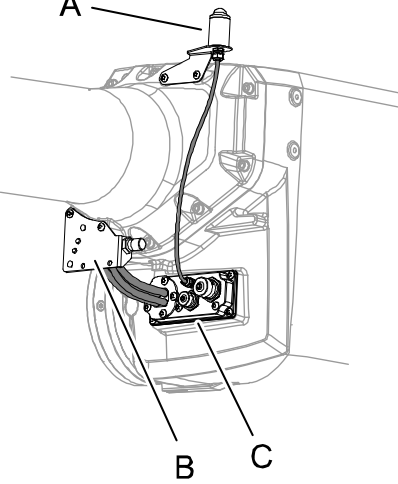
Continued

	Action	Note
5	Secure the <i>bracket, armhouse</i> with its attachment screws.	 <p>xx0800000335</p> <p>Parts:</p> <ul style="list-style-type: none"> <li>• A: Tubular shaft unit</li> <li>• B: Attachment screws</li> <li>• C: Bracket, armhouse</li> </ul>
6	Secure the <i>bracket</i> to the armhouse with its attachment screws.	 <p>xx0800000338</p> <p>Parts:</p> <ul style="list-style-type: none"> <li>• A: Signal lamp</li> <li>• B: Bracket, armhouse</li> <li>• C: Cable bracket</li> </ul>
7	Reconnect the axis-3, axis-4, axis-5 and axis-6 <i>motor cables</i> .	How to connect the axis-3, axis-4, axis-5 and axis-6 motor cables, see: <ul style="list-style-type: none"> <li>• <a href="#">Refitting motors on page 313</a></li> </ul>
8	Seal and paint the joints that have been opened. Also repair possible damages of the special Foundry Prime paint coat of the robot. See <a href="#">Cut the paint or surface on the robot before replacing parts on page 200</a> .	
9	Recalibrate the robot.	Pendulum Calibration is described in <i>Operating manual - Calibration Pendulum</i> , enclosed with the calibration tools. Axis Calibration is described in <a href="#">Calibrating with Axis Calibration method on page 367</a> . General calibration information is included in section <a href="#">Calibration on page 353</a> .

Continues on next page

	Action	Note
10	 <b>WARNING</b> The cover on the armhouse must be fitted when the robot is running. It is a vital part for the stability of the robot.	
11	 <b>DANGER</b> Make sure all safety requirements are met when performing the first test run.	

## 4 Repair

### 4.3.3 Replacement of air nipples and hoses (Foundry Prime)

### 4.3.3 Replacement of air nipples and hoses (Foundry Prime)

#### Function

The pressure inside the areas A and B are 0.2 - 0.3 bar.

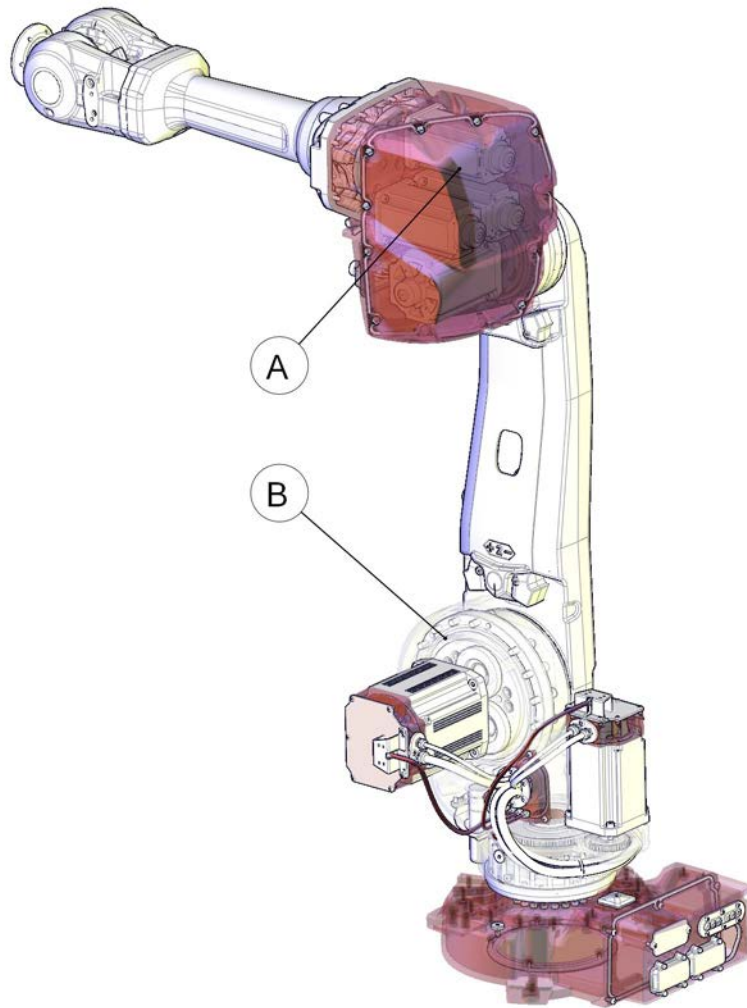

xx110000047

#### Required equipment

Equipment	Note
Standard toolkit	Content is defined in section <a href="#">Standard tools on page 398</a> .
Other tools and procedures may be required. See references to these procedures in the step-by-step instructions below.	These procedures include references to the tools required.
Loctite 577	12691907-1
Rust preventive	3HAC026621-001

*Continues on next page*

Equipment	Note
Brush	-

## Additional equipment - Foundry Prime

Equipment	Art. no.	Note
Rust preventive	3HAC034903-001	Mercasol
Sikaflex 521FC	3HAC026759-001	
Loctite 574	12340011-116	
Brush		
Foundry Prime touch up kit	3HAC035355-001	

**Note**

Make sure that the special Foundry Prime painting of the robot is not broke during testing, installation or repair work. Use touch up kit available for Foundry Prime art. no. 3HAC035355-001 to repair the damage paint coat see section [Cut the paint or surface on the robot before replacing parts on page 200.](#)

**CAUTION**

Always cut the paint with a knife and grind the paint edge when disassembling parts. See [Cut the paint or surface on the robot before replacing parts on page 200.](#)

Continues on next page

## 4 Repair

---

### 4.3.3 Replacement of air nipples and hoses (Foundry Prime)

*Continued*

---

#### Replacing air hoses and nipples

The illustration show the routing of the pressure hoses on a IRB 4600 Foundry Prime robot.

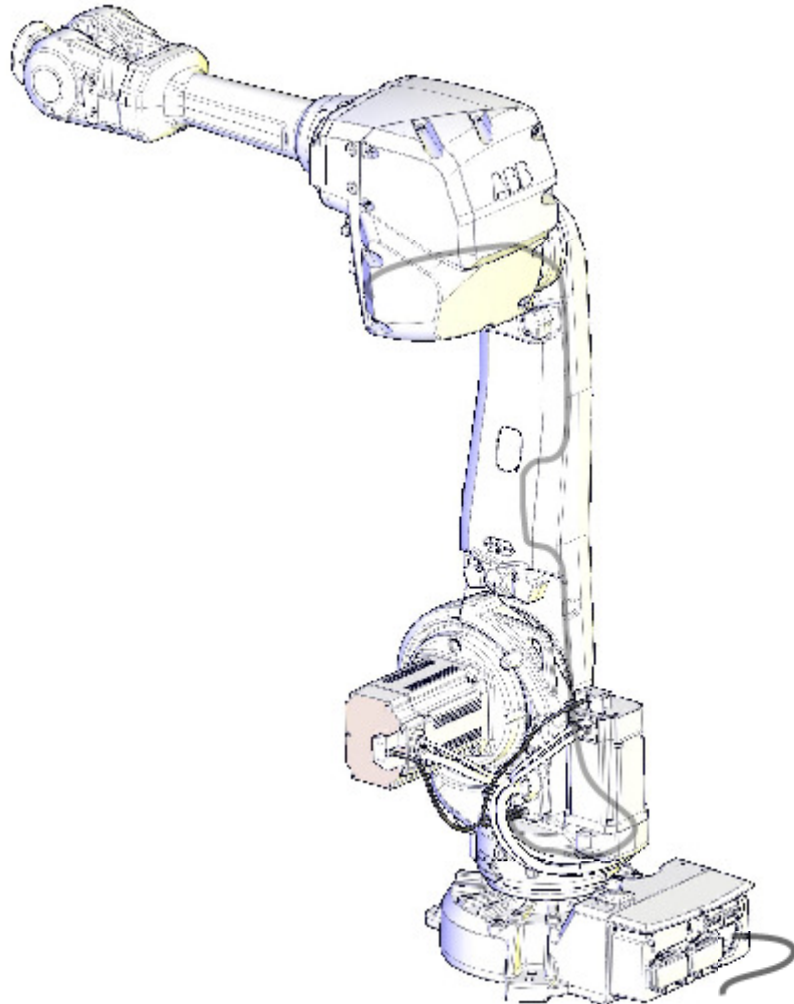

xx110000049

*Continues on next page*

4.3.3 Replacement of air nipples and hoses (Foundry Prime)

Continued

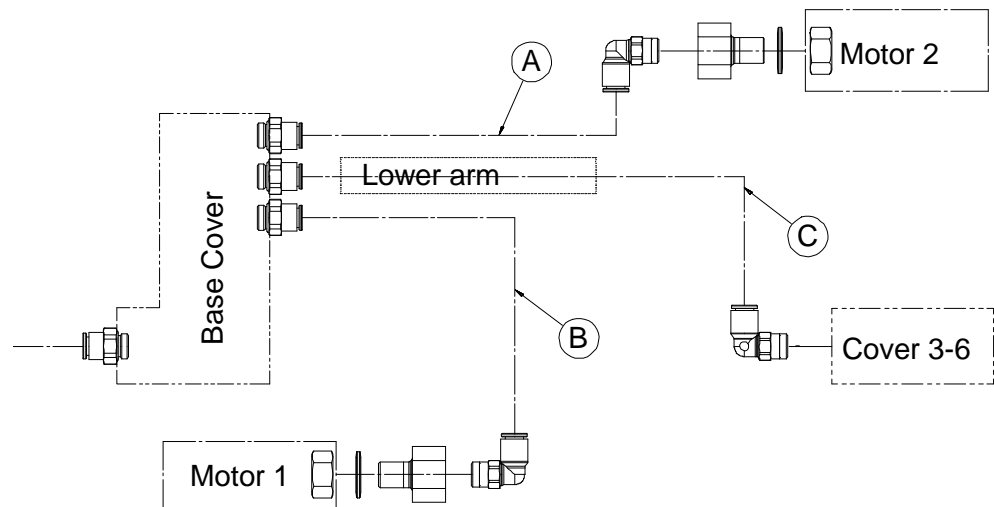

xx110000051

A	Pneumatic hose - Foundry Prime 360 mm
B	Pneumatic hose - Foundry Prime 410 mm
C	Pneumatic hose - Foundry Prime 2500 mm

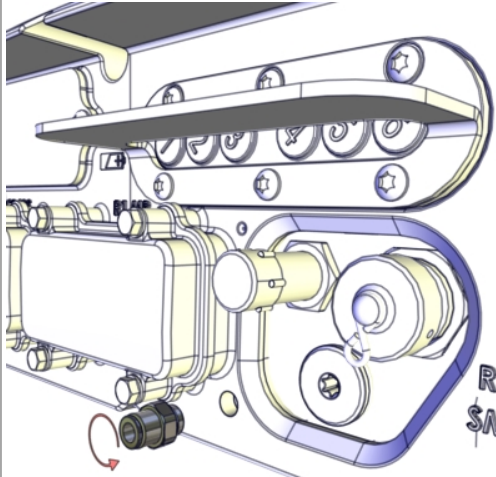
Action	Information
<p>1</p> <p> <b>DANGER</b></p> <p>Turn off all:</p> <ul style="list-style-type: none"> <li>• electric power supply</li> <li>• hydraulic pressure supply</li> <li>• air pressure supply</li> </ul> <p>to the robot, before entering the safe-guarded space.</p>	
<p>2</p> <p>Remove hose, and remove the straight fitting from the manipulator base.</p>	 <p>xx1500002400</p>

Continues on next page

## 4 Repair

### 4.3.3 Replacement of air nipples and hoses (Foundry Prime)

*Continued*

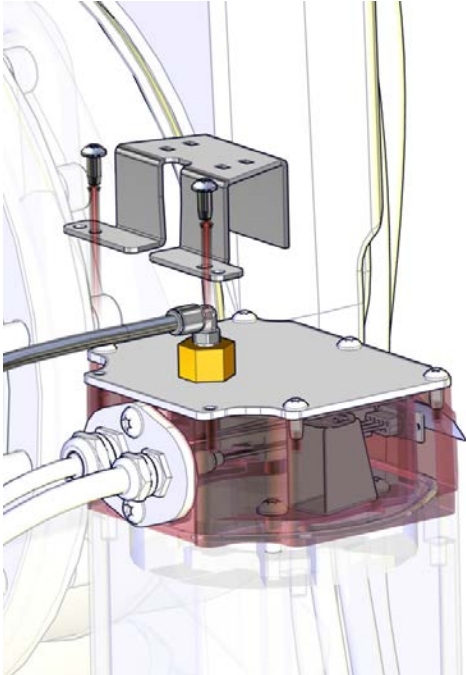
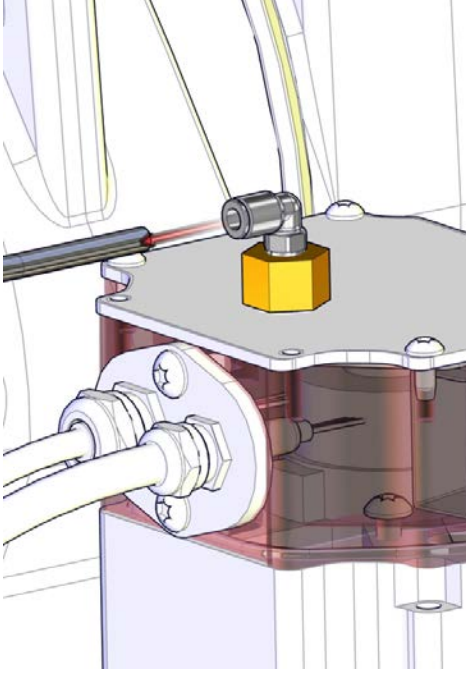
	Action	Information
3	Remove the hose protection from motor 1 and 2. Use standard tools.	 <p data-bbox="911 992 1018 1010">xx110000053</p>
4	Remove the hoses from the elbow fittings. No tools needed.	 <p data-bbox="911 1731 1018 1749">xx110000054</p>

*Continues on next page*



**4.3.3 Replacement of air nipples and hoses (Foundry Prime)**

*Continued*

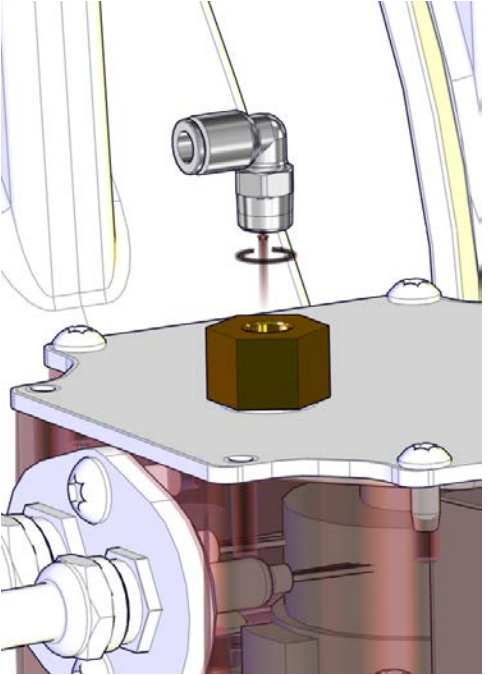
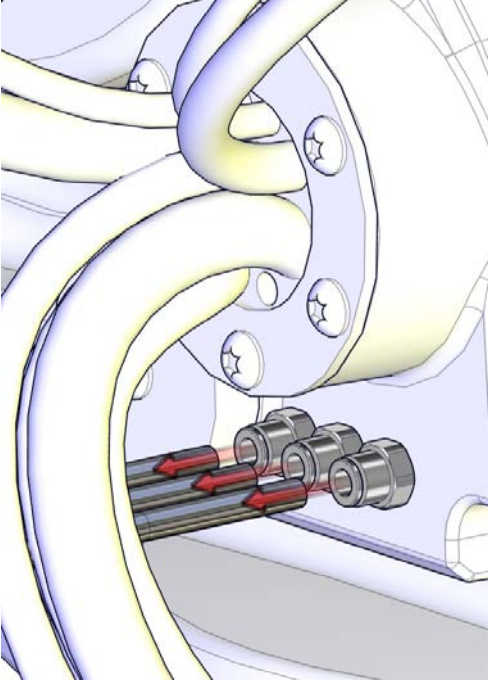
	Action	Information
5	Remove the elbow fittings. Use standard tools	 <p>xx110000055</p>
6	Remove hoses from the straight fittings on the cover at the frame. No tools needed.	 <p>xx110000056</p>
7	Remove the straight fittings on the cover at the frame. Use standard tools.	

*Continues on next page*

## 4 Repair

### 4.3.3 Replacement of air nipples and hoses (Foundry Prime)

*Continued*

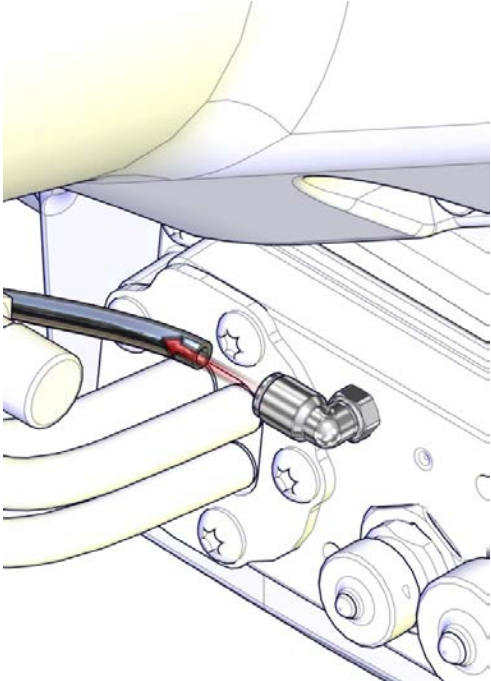
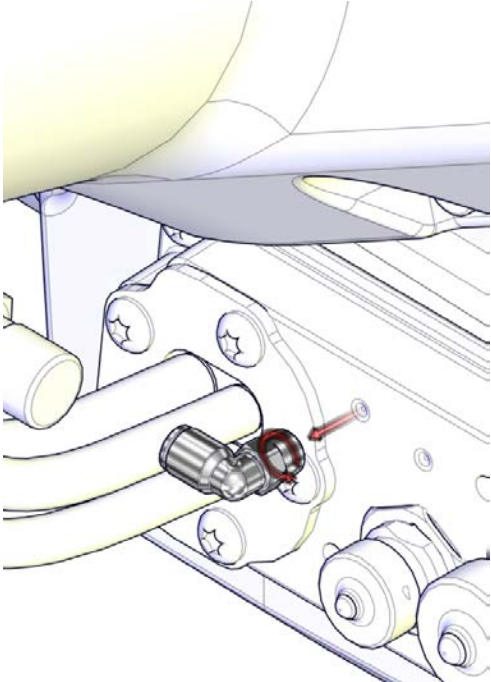
	Action	Information
8	Remove the Pneumatic hose - Foundry Prime 2500 mm from the upper elbow-fitting.	 <p>xx110000059</p>
9	Remove the upper elbow fitting.	 <p>xx110000060</p>

*Continues on next page*

4.3.3 Replacement of air nipples and hoses (Foundry Prime)

Continued

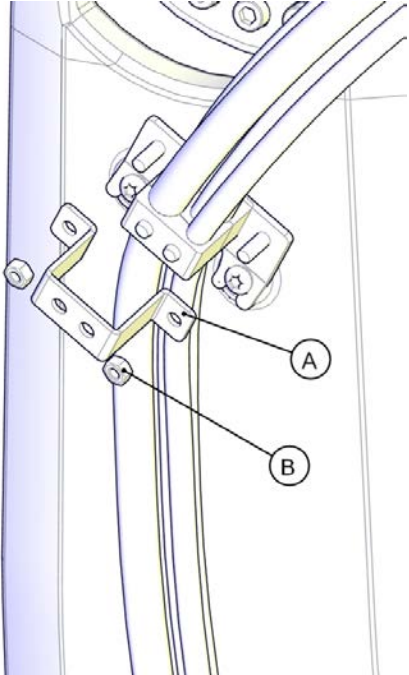
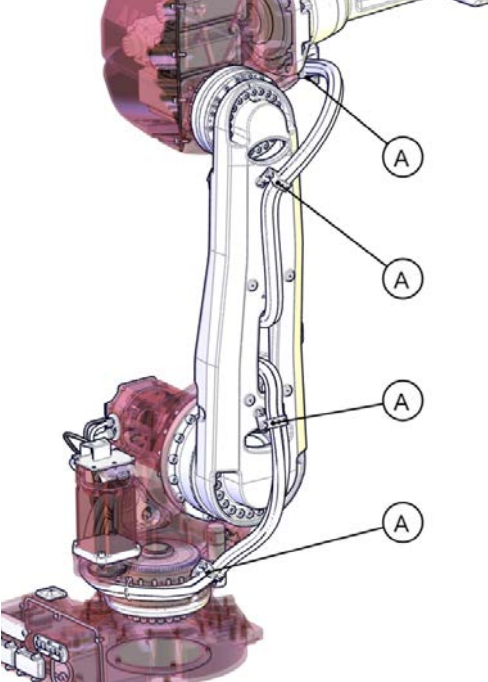
	Action	Information
10	<p>Remove the nuts (B) on all the hose clamps (A). Use standard tools.</p> <p> <b>Note</b></p> <p>It is important to maintain the position of the hoses and the hose clamps. Use a cable strap to secure the position of the rubber blocks.</p>	 <p>xx110000058</p>
11	<p>Remove all hose clamps (A) from the lower arm.</p>	 <p>xx110000057</p>
12	<p>Remove the Pneumatic hose - Foundry Prime 2500 mm from the upper arm.</p>	



Continues on next page

## 4 Repair

### 4.3.3 Replacement of air nipples and hoses (Foundry Prime)

*Continued*

#### Refitting air hoses and nipples

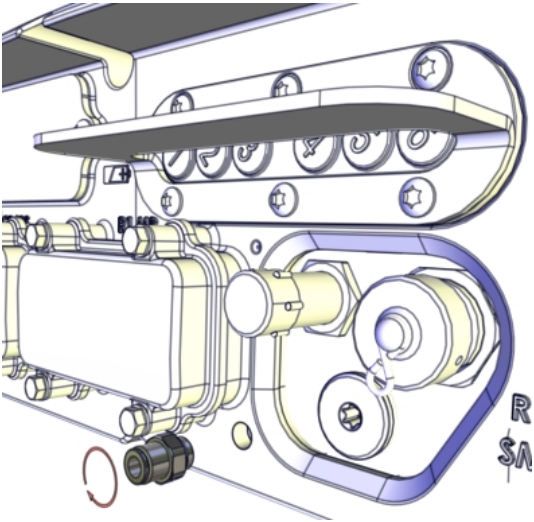
	Action	Information
1	 <b>Note</b> Apply rust preventive around all dismantled covers and attachment screws with a brush.	
2	 <b>Note</b> Always apply rust preventive (Mercasol) on covers, attachment plates and screws after refitting these components.	
3	Refit the straight fitting on the manipulator base. Apply Loctite 577 on the thread. Use standard tools.	 xx1500002401

*Continues on next page*

**4.3.3 Replacement of air nipples and hoses (Foundry Prime)**  
*Continued*

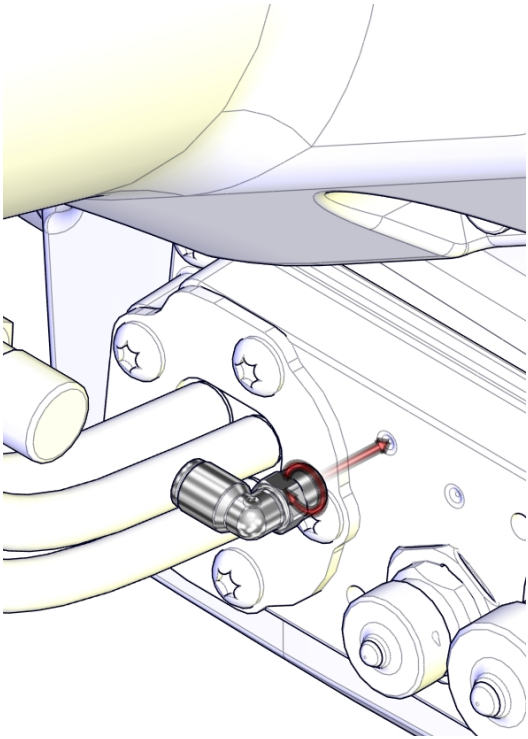
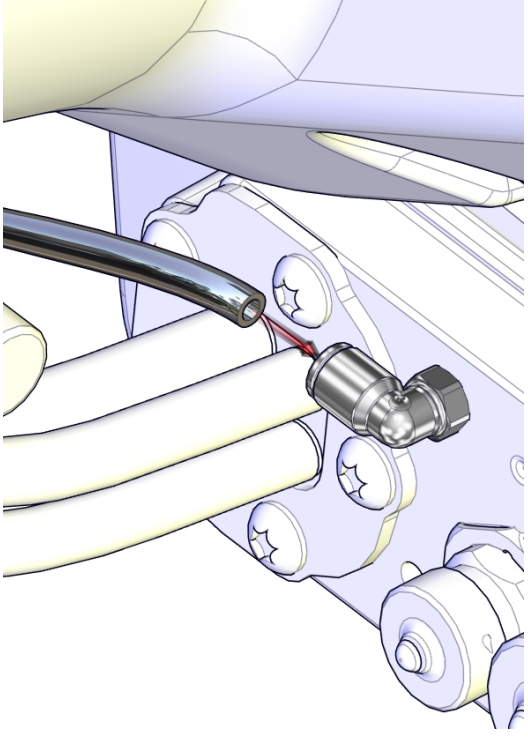
	<b>Action</b>	<b>Information</b>
4	Refit the upper elbow fitting. Apply Loctite 577 on the thread. Use standard tools.	 <p>xx110000061</p>
5	Refit the upper hose in the elbow-fitting.	 <p>xx110000062</p>

*Continues on next page*

## 4 Repair

### 4.3.3 Replacement of air nipples and hoses (Foundry Prime)

Continued

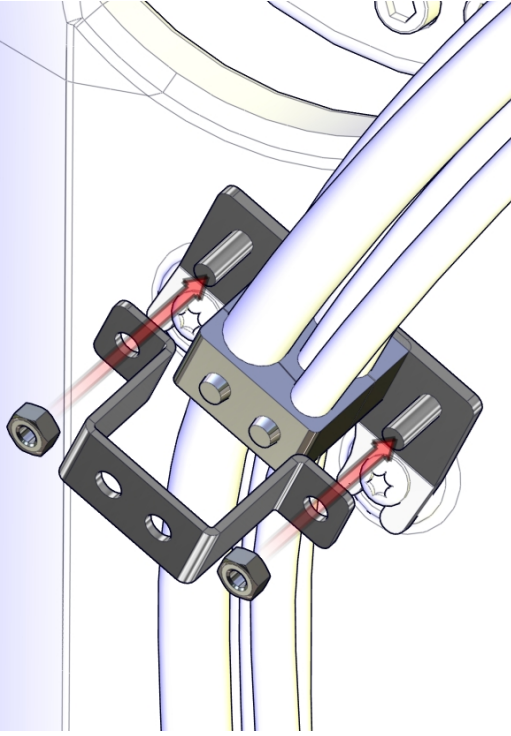
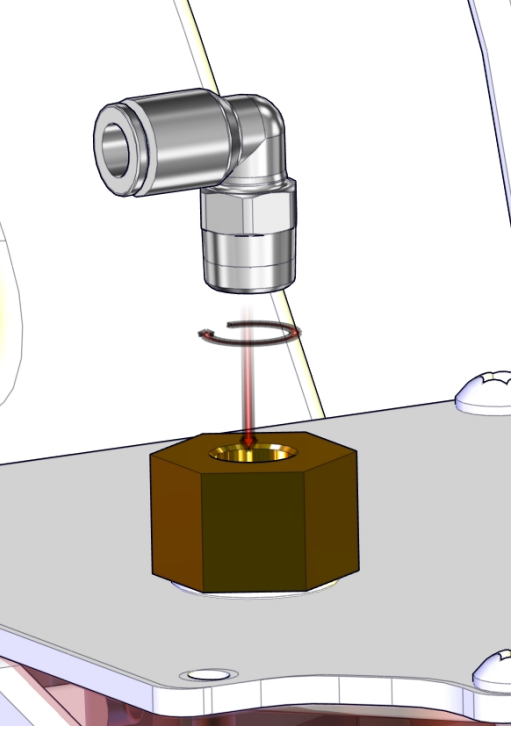
	Action	Information
6	<p>Refit all hose clamps</p> <p> <b>CAUTION</b></p> <p>The position of the hoses and the hose clamps is essential. Changed-position can cause wear on the hoses.</p>	 <p>xx110000066</p>
7	<p>Refit the elbow fittings on the motors. Apply Loctite 577 on the thread. Use standard tools.</p>	 <p>xx110000068</p>
8	<p>Refit the hose on the elbow fitting.</p>	

Continues on next page



4.3.3 Replacement of air nipples and hoses (Foundry Prime)

Continued

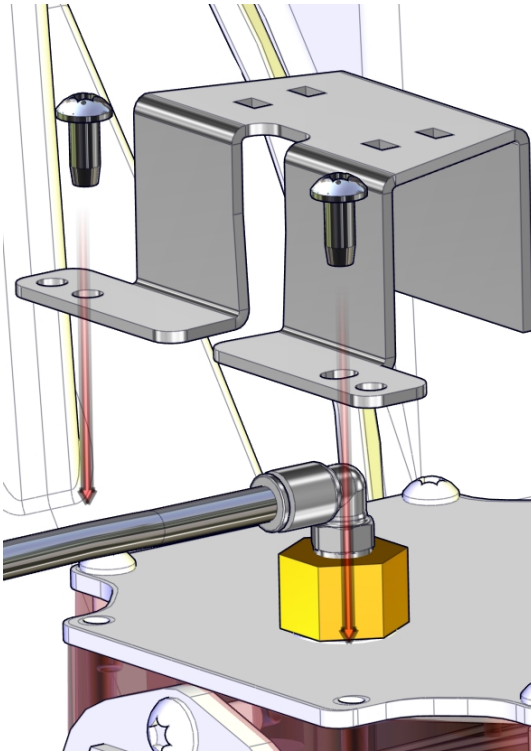
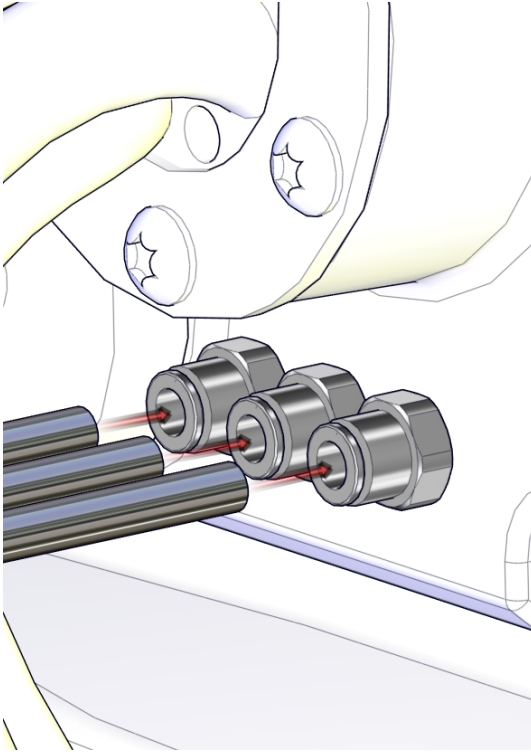
	Action	Information
9	Refit the hose protection on motor 1 and 2. Use standard tools.	 <p>xx110000069</p>
10	Refit the straight fittings on the cover at the frame. Apply Loctite 577 on the thread. Use standard tools.	
11	Refit the hoses on the straight fittings on the cover at the frame.	 <p>xx110000070</p>

## 4 Repair

### 4.3.4 Replacing SMB unit

#### 4.3.4 Replacing SMB unit

##### Location of SMB unit

The SMB unit (SMB = Serial measurement board) is located in the base below the brake release unit, as shown in the figure.

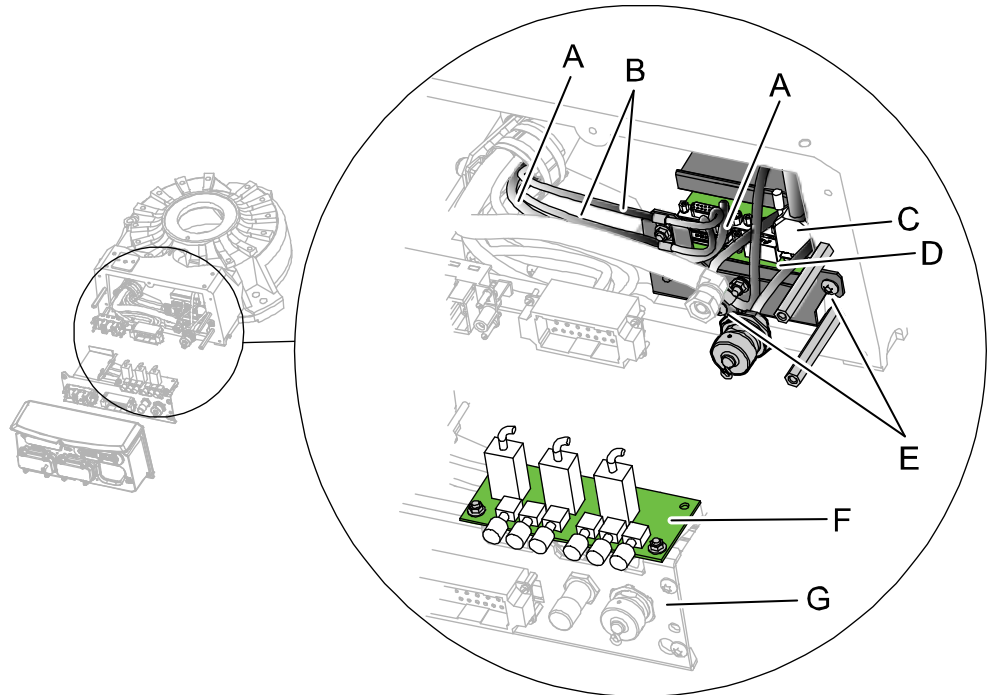

xx080000466

A	R1.SMB3-6
B	R1.SMB1-2
C	R2.SMB
D	SMB unit
E	Attachment screws M6x16 quality 8.8-A2F (2 pcs)
F	Brake release unit
G	Bracket

##### Required equipment



##### Note

There are different variants of SMB units and batteries. The variant with the 3-pole battery contact (RMU) has longer lifetime for the battery.

It is important that the SMB unit uses the correct battery. Make sure to order the correct spare parts. Do not replace the battery contact!

Equipment	Note
Standard toolkit	Content is defined in section <a href="#">Standard tools on page 398</a> .

Continues on next page



Equipment	Note
Other tools and procedures may be required. See references to these procedures in the step-by-step instructions below.	These procedures include references to the tools required.
SMB unit	For spare part no. see chapter Spare parts, section: <ul style="list-style-type: none"> <li><a href="#">Spare part lists on page 403</a></li> </ul>

#### Additional equipment - Foundry Prime

Equipment	Art. no.	Note
Rust preventive	3HAC034903-001	Mercasol
Sikaflex 521FC	3HAC026759-001	
Loctite 574	12340011-116	
Brush		
Foundry Prime touch up kit	3HAC035355-001	

#### Deciding calibration routine

Decide which calibration routine to be used, based on the information in the table. Depending on which routine is chosen, action might be required prior to beginning the repair work of the robot, see the table.

Action	Note
1 Decide which calibration routine to use for calibrating the robot. <ul style="list-style-type: none"> <li>Reference calibration. External cable packages (DressPack) and tools can stay fitted on the robot.</li> <li>Fine calibration. All external cable packages (DressPack) and tools must be removed from the robot.</li> </ul>	
<p><b>If the robot is to be calibrated with reference calibration:</b></p> <p>Find previous reference values for the axis or create new reference values. These values are to be used after the repair procedure is completed, for calibration of the robot.</p> <p>If no previous reference values exist, and no new reference values can be created, then reference calibration is not possible.</p>	<p>Follow the instructions given in the reference calibration routine on the FlexPendant to create reference values.</p> <p>Creating new values requires possibility to move the robot.</p> <p>Read more about reference calibration for Axis Calibration in <a href="#">Reference calibration routine on page 368</a>.</p> <p>Read more about reference calibration for Pendulum Calibration in <i>Operating manual - Calibration Pendulum</i>.</p>
<p><b>If the robot is to be calibrated with fine calibration:</b></p> <p>Remove all external cable packages (DressPack) and tools from the robot.</p>	

Continues on next page



## 4 Repair

### 4.3.4 Replacing SMB unit



Continued

#### Removing the SMB unit

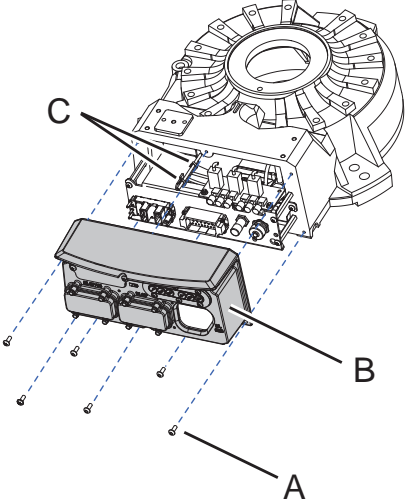
Use this procedure to remove the SMB unit.

	Action	Note
1	Decide which calibration routine to use, and take actions accordingly prior to beginning the repair procedure.	
2	 <b>DANGER</b> Turn off all: <ul style="list-style-type: none"> <li>• electric power supply</li> <li>• hydraulic pressure supply</li> </ul> to the robot, before entering the robot working area.	
3	 <b>CAUTION</b> Always cut the paint with a knife and grind the paint edge when disassembling parts. See <a href="#">Cut the paint or surface on the robot before replacing parts on page 200</a> .	
4	Remove the <i>base cover</i> .  <b>CAUTION</b> Clean cover from metal residues before opening. Metal residues can cause shortage on the boards which can result in hazardous failures.	 <p>xx0900000103</p> <p><b>Parts:</b></p> <ul style="list-style-type: none"> <li>A Attachment screws (6 pcs)</li> <li>B Base cover</li> <li>C Cable straps, securing the battery cable (2 pcs)</li> </ul>
5	Cut the <i>cable straps</i> securing the battery cable.	

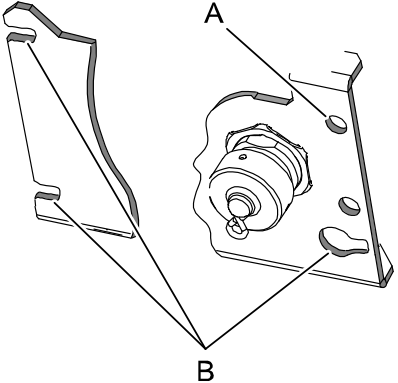
Continues on next page

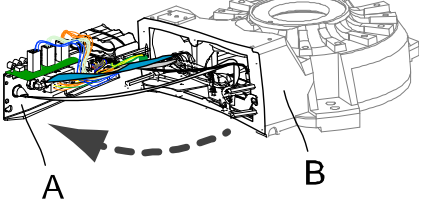
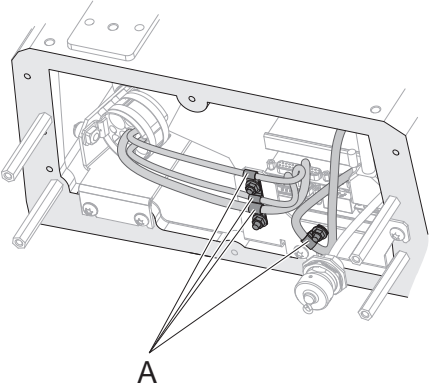
	Action	Note
6	<p>Remove the screw that secures the bracket and unscrew the three other screws a little just enough to be able to slide the bracket sideways.</p> <p> <b>Note</b></p> <p>It is not needed to remove these three screws.</p>	 <p>xx0900000100</p> <p><b>Parts:</b></p> <ul style="list-style-type: none"> <li>A Screw to be removed</li> <li>B Screws to be unscrewed a little (3 pcs)</li> </ul>
7	<p>Remove the <i>bracket</i> by sliding it off the remaining three attachment screws and put it at a 90° angle from the base.</p> <p>Putting the bracket at a 90° angle facilitates the disconnecting of cables from the bracket.</p> <p> <b>Note</b></p> <p>Use caution when performing this procedure order not to damage cables or other components!</p>	<p>Cable harness can stay connected to all connectors except to the SMB unit.</p>  <p>xx0900000013</p> <p><b>Parts:</b></p> <ul style="list-style-type: none"> <li>A Bracket at a 90° angle</li> <li>B Base</li> </ul>
8	<p>Disconnect cable clamps.</p>	 <p>xx0900000035</p> <p><b>Parts:</b></p> <ul style="list-style-type: none"> <li>A Cable clamps</li> </ul>
9	<p>Unscrew the <i>attachment screws</i> securing the SMB unit just enough to be able to remove the SMB unit.</p>	<p>See the figure in:</p> <ul style="list-style-type: none"> <li>• <a href="#">Location of SMB unit on page 244</a></li> </ul>
10	<p>Remove the SMB unit.</p>	

Continues on next page

## 4 Repair

### 4.3.4 Replacing SMB unit

Continued

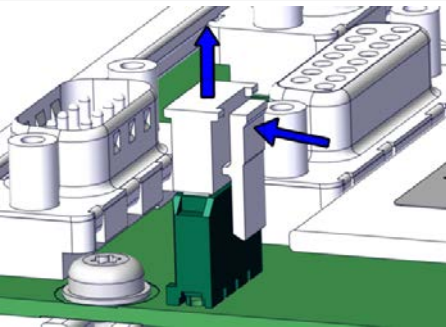

	Action	Note
11	Disconnect the battery cable by pressing down the upper lip of the R1.G connector to release the lock while pulling the connector upwards.	 <p>xx170000993</p>
12	Disconnect the remaining connectors on the SMB unit: <ul style="list-style-type: none"> <li>• R1.SMB1-2</li> <li>• R1.SMB3-6</li> <li>• R2.SMB</li> </ul>	See the figure in: <ul style="list-style-type: none"> <li>• <a href="#">Location of SMB unit on page 244</a></li> </ul>

### Refitting the SMB unit

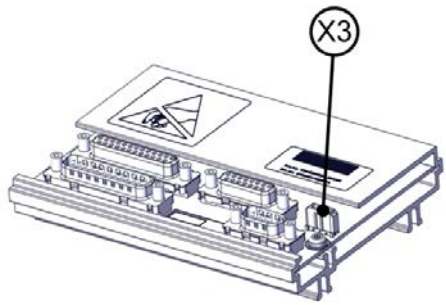
Use this procedure to refit the SMB unit.

	Action	Note
1	 <p><b>DANGER</b></p> <p>Turn off all:</p> <ul style="list-style-type: none"> <li>• electric power supply</li> <li>• hydraulic pressure supply</li> </ul> <p>to the robot, before entering the robot working area.</p>	
2	Clean the joints that have been opened. See <a href="#">Cut the paint or surface on the robot before replacing parts on page 200</a>	
3	Reconnect contacts on the SMB unit: <ul style="list-style-type: none"> <li>• R1.SMB1-2</li> <li>• R1.SMB3-6</li> <li>• R2.SMB</li> <li>• Battery cable R1.G (X3) Make sure the lock snaps into place during refitting.</li> </ul>	 <p>xx170000994</p>
4	Place the SMB unit on its <i>attachment screws</i> .	See the figure in: <ul style="list-style-type: none"> <li>• <a href="#">Location of SMB unit on page 244</a></li> </ul>
5	Secure the SMB unit with its attachment screws.	

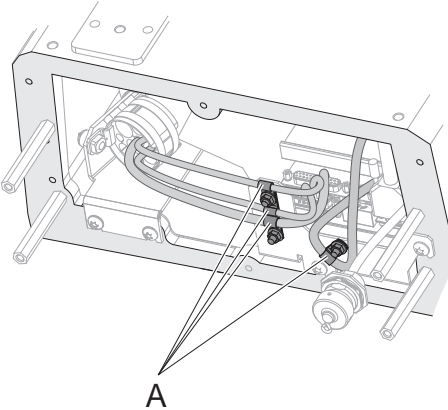
Continues on next page

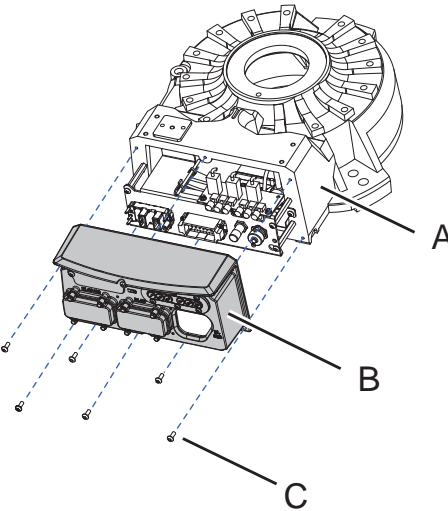
	Action	Note
6	Refit the <i>cable clamps</i> .	 <p>xx0900000035</p> <p>Parts: A Cable clamps</p>
7	Put back the cable harness in the base and refit the bracket on the distance screws.   <b>Note</b> Use caution when performing this procedure order not to damage cables or other components!	See the figure in: <ul style="list-style-type: none"> <li>• <a href="#">Location of SMB unit on page 244</a></li> </ul>
8	Secure the battery cable with cable straps.	
9	Use caution when pushing the <i>base cover</i> into position while at the same time checking that no cables are damaged.	
10	Secure the <i>base cover</i> with the attachment screws.	 <p>xx0800000456</p> <p>Parts: A Attachment screws (6 pcs) B Base cover C Base</p>
11	Seal and paint the joints that have been opened. Also repair possible damages of the special Foundry Prime paint coat of the robot. See <a href="#">Cut the paint or surface on the robot before replacing parts on page 200</a> .	

*Continues on next page*

## 4 Repair

### 4.3.4 Replacing SMB unit

*Continued*

	Action	Note
12	Recalibrate the robot.	Pendulum Calibration is described in <i>Operating manual - Calibration Pendulum</i> , enclosed with the calibration tools. Axis Calibration is described in <a href="#">Calibrating with Axis Calibration method on page 367</a> . General calibration information is included in section <a href="#">Calibration on page 353</a> .
13	 <b>DANGER</b> Make sure all safety requirements are met when performing the first test run.	

### 4.3.5 Replacing the brake release board

#### Location of brake release board

The brake release board is located as shown in the figure.

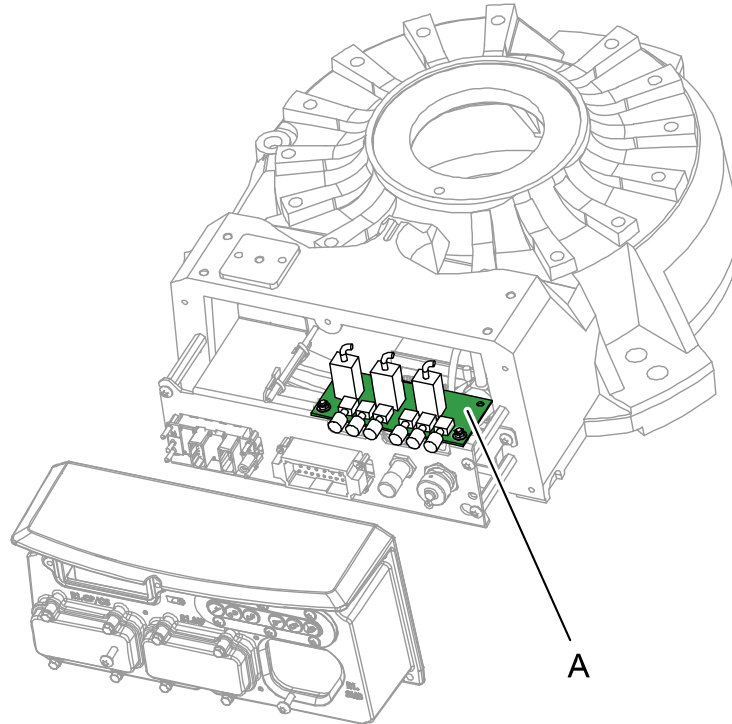

xx090000101

A	Brake release board
---	---------------------

#### Connectors on push-button board

The connectors X8, X9 and X10 are placed on the push-button board as shown in the figure below.

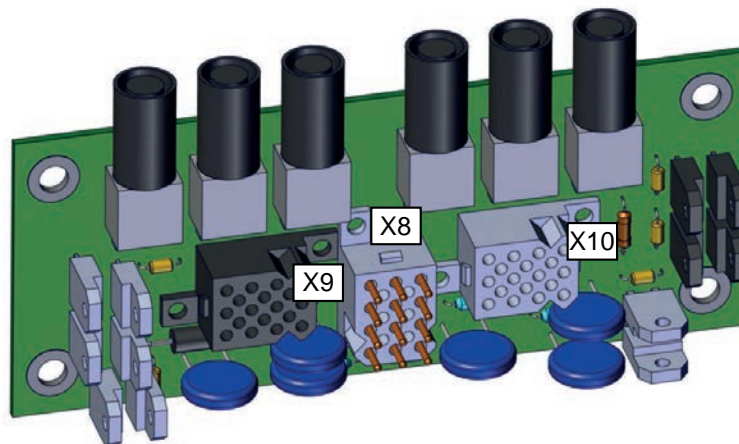

xx170000978

*Continues on next page*

## 4 Repair

### 4.3.5 Replacing the brake release board

*Continued*

#### Required equipment

Equipment		Note
Brake release board	3HAC065020-001 <sup>i</sup> 3HAC062021-001 <sup>ii</sup>	DSQC1050 DSQC1052
Standard toolkit		Content is defined in section <a href="#">Standard tools on page 398</a> .
Other tools and procedures may be required. See references to these procedures in the step-by-step instructions below.		These procedures include references to the tools required.

<sup>i</sup> Valid for robots that are equipped with motors of Type A and Type B (see *Product manual, spare parts - IRB 4600*).

Includes brake release board and harness.

<sup>ii</sup> Valid for robots that are equipped with motors of Type B (see *Product manual, spare parts - IRB 4600*).



Includes brake release board and harness.

#### Additional equipment - Foundry Prime

Equipment	Art. no.	Note
Rust preventive	3HAC034903-001	Mercasol
Sikaflex 521FC	3HAC026759-001	
Loctite 574	12340011-116	
Brush		
Foundry Prime touch up kit	3HAC035355-001	



#### Removing the brake release board

Use this procedure to remove the brake release board.

	Action	Note
1	 <b>DANGER</b> Turn off all: <ul style="list-style-type: none"> <li>• electric power supply</li> <li>• hydraulic pressure supply</li> </ul> to the robot, before entering the robot working area.	
2	 <b>ELECTROSTATIC DISCHARGE (ESD)</b> The unit is sensitive to ESD. Before handling the unit read the safety information in section <a href="#">The unit is sensitive to ESD on page 56</a> .	

*Continues on next page*

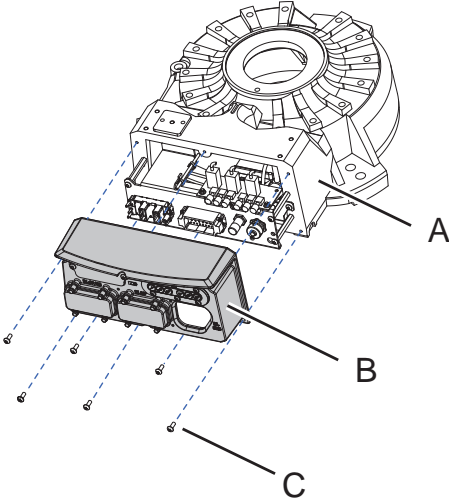
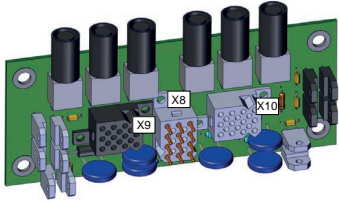

	Action	Note
3	<p> <b>CAUTION</b></p> <p>Always cut the paint with a knife and grind the paint edge when disassembling parts. See <a href="#">Cut the paint or surface on the robot before replacing parts on page 200</a>.</p>	
4	<p>Remove the <i>push button guard</i> from the SMB cover.</p>	<p>The guard must be removed to ensure a correct refitting of the brake release board.</p>
5	<p>Remove the <i>base cover</i>.</p> <p> <b>CAUTION</b></p> <p>Clean cover from metal residues before opening.</p> <p>Metal residues can cause shortage on the boards which can result in hazardous failures.</p>	 <p>xx0800000456</p> <p>Parts:</p> <ul style="list-style-type: none"> <li>A Base</li> <li>B Base cover</li> <li>C Attachment screws M6x16 quality 8.8-A2F (6 pcs)</li> </ul>
6	<p>Take a picture or make notes of how the robot cabling is positioned in regard to the brake release board.</p>	
7	<p>Disconnect <i>connectors X8, X9 and X10</i> from the brake release board.</p>	 <p>xx1700000978</p>
8	<p>Remove the <i>nuts</i> securing the brake release board.</p>	
9	<p>Remove the brake release board.</p>	

Continues on next page





## 4 Repair

### 4.3.5 Replacing the brake release board

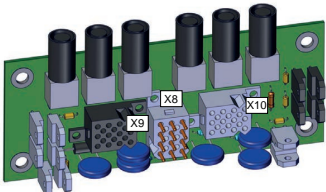

*Continued*

#### Refitting the brake release board

Use this procedure to refit the brake release board.

	Action	Note
1	 <p><b>DANGER</b></p> <p>Turn off all:</p> <ul style="list-style-type: none"> <li>• electric power supply</li> <li>• hydraulic pressure supply</li> </ul> <p>to the robot, before entering the robot working area.</p>	
2	 <p><b>ELECTROSTATIC DISCHARGE (ESD)</b></p> <p>The unit is sensitive to ESD. Before handling the unit read the safety information in section <a href="#">The unit is sensitive to ESD on page 56</a>.</p>	
3	<p>Clean the joints that have been opened. See <a href="#">Cut the paint or surface on the robot before replacing parts on page 200</a></p>	
4	<p>Secure the brake release board to the <i>bracket</i> with its <i>nuts with flange</i>.</p>	<p>Maximum tightening torque: 5 Nm.</p> <p>See the figure in:</p> <ul style="list-style-type: none"> <li>• <a href="#">Location of brake release board on page 251</a></li> </ul>
5	<p>Reconnect <i>connectors X8, X9 and X10</i> to the brake release board.</p> <p>Be careful not to damage the sockets or pins. Make sure the connector and its locking arms are snapped down properly.</p>	 <p>xx1700000978</p>
6	<p>Verify that the robot cabling is positioned correctly, according to previously taken picture/notes.</p>  <p><b>WARNING</b></p> <p>Screened cables must not get in contact with the brake release board after installation. Eliminate all risks of contact between screened cables and the brake release board.</p>	

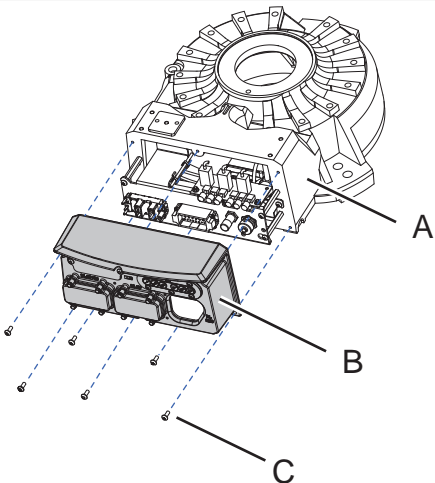
*Continues on next page*

	Action	Note
7	Use caution when pushing the <i>base cover</i> into position while at the same time checking that no cables are damaged.	 <p data-bbox="1000 795 1109 817">xx0800000456</p> <p data-bbox="1000 840 1437 992"> <b>Parts:</b>                      A Base                      B Base cover                      C Attachment screws M6x16 quality 8.8-A2F (6 pcs)                 </p>
8	Secure the <i>base cover</i> with its <i>attachment screws</i> .	
9	 <p data-bbox="590 1108 710 1131"><b>WARNING</b></p> <p data-bbox="502 1164 995 1276">Before continuing any service work, follow the safety procedure in section <i>The brake release buttons may be jammed after service work on page 202!</i></p>	
10	Refit the <i>push button guard</i> to the SMB cover.	
11	Press the push buttons 1 to 6, one at a time, to make sure that the buttons are moving freely and do not stay in any locked position.	
12	Seal and paint the joints that have been opened. Also repair possible damages of the special Foundry Prime paint coat of the robot. See <i>Cut the paint or surface on the robot before replacing parts on page 200.</i>	
13	 <p data-bbox="590 1641 694 1664"><b>DANGER</b></p> <p data-bbox="502 1697 995 1753">Make sure all safety requirements are met when performing the first test run.</p>	

## 4 Repair

### 4.3.6 Replacing the base

### 4.3.6 Replacing the base

#### Location of base and complete arm system

The complete arm system is defined as:

- complete upper arm (includes: wrist unit, tubular shaft unit and armhouse)
- lower arm
- frame
- axis-1 gearbox

The location of the base and the complete arm system is shown in the figure.

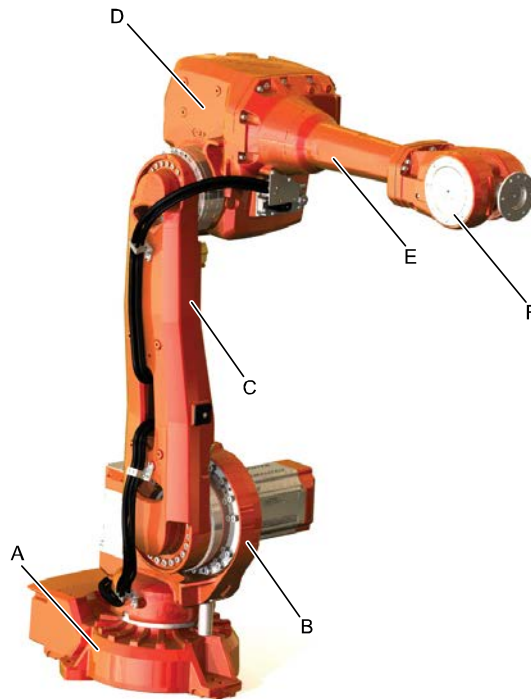

xx080000345

A	Base
B	Frame
C	Lower arm
D	Arm house (part of complete upper arm)
E	Tubular shaft unit (part of complete upper arm)
F	Wrist unit (part of complete upper arm)

#### Required equipment

Equipment	Article number	Note
Roundslings	-	Length: 2 m (2 pcs), 1.5 m (1 pcs) Lifting capacity: 1,000 kg.
Support legs	3HAC15535-1	3 pcs
Guide pin, M8x150	3HAC15520-2	Always use guide pins in pairs.

*Continues on next page*

Equipment	Article number	Note
Lifting eye	-	M8 3 pcs
Standard toolkit		Content is defined in section <a href="#">Standard tools on page 398</a> .
Other tools and procedures may be required. See references to these procedures in the step-by-step instructions below.		These procedures include references to the tools required.
Cleaning agent	-	Loctite 7063 For cleaning.
Flange sealant	-	Loctite 574 For sealing.

#### Additional equipment - Foundry Prime

Equipment	Art. no.	Note
Rust preventive	3HAC034903-001	Mercasol
Sikaflex 521FC	3HAC026759-001	
Loctite 574	12340011-116	
Brush		
Foundry Prime touch up kit	3HAC035355-001	

#### Deciding calibration routine

Decide which calibration routine to be used, based on the information in the table. Depending on which routine is chosen, action might be required prior to beginning the repair work of the robot, see the table.

	Action	Note
1	<p>Decide which calibration routine to use for calibrating the robot.</p> <ul style="list-style-type: none"> <li>Reference calibration. External cable packages (DressPack) and tools can stay fitted on the robot.</li> <li>Fine calibration. All external cable packages (DressPack) and tools must be removed from the robot.</li> </ul>	
	<p><b>If the robot is to be calibrated with reference calibration:</b></p> <p>Find previous reference values for the axis or create new reference values. These values are to be used after the repair procedure is completed, for calibration of the robot.</p> <p>If no previous reference values exist, and no new reference values can be created, then reference calibration is not possible.</p>	<p>Follow the instructions given in the reference calibration routine on the FlexPendant to create reference values.</p> <p>Creating new values requires possibility to move the robot.</p> <p>Read more about reference calibration for Axis Calibration in <a href="#">Reference calibration routine on page 368</a>.</p> <p>Read more about reference calibration for Pendulum Calibration in <i>Operating manual - Calibration Pendulum</i>.</p>

Continues on next page

## 4 Repair





### 4.3.6 Replacing the base

Continued



Action	Note
<p>If the robot is to be calibrated with fine calibration:</p> <p>Remove all external cable packages (DressPack) and tools from the robot.</p>	

### Removing the base

Use this procedure to remove the complete arm system from the base.

Action	Note	
1	Decide which calibration routine to use, and take actions accordingly prior to beginning the repair procedure.	
2	Jog the robot to: <ul style="list-style-type: none"> <li>• Axis 1: 0°</li> <li>• Axis 2: 0°</li> <li>• Axis 3: -10°</li> <li>• Axis 4: 0°</li> <li>• Axis 5: 0°</li> <li>• Axis 6: 0°</li> </ul>	
3	 <b>DANGER</b> Turn off all: <ul style="list-style-type: none"> <li>• electric power supply</li> <li>• hydraulic pressure supply</li> </ul> to the robot, before entering the safe-guarded space.	
4	 <b>CAUTION</b> Always cut the paint with a knife and grind the paint edge when disassembling parts. See <a href="#">Cut the paint or surface on the robot before replacing parts on page 200</a> .	
5	Drain the axis-1 gearbox.  <b>Note</b> Draining is time-consuming. Elapsed time varies depending on the temperature of the oil.	How to drain oil is detailed in section <ul style="list-style-type: none"> <li>• <a href="#">Changing the oil, axis 1 gearbox on floor mounted robots on page 153</a></li> </ul>
6	Remove the <i>cable harness</i> in the base, the frame and the lower arm of the robot.  <b>Tip</b> Wrap up the cabling against the frame to keep it undamaged during the remaining work.	How to remove the cable harness in base and frame is detailed in sections: <ul style="list-style-type: none"> <li>• <a href="#">Removing cable harness in base on page 206</a></li> <li>• <a href="#">Removing cable harness in frame on page 211</a></li> <li>• <a href="#">Removing cable harness in lower arm and armhouse on page 213</a></li> </ul>

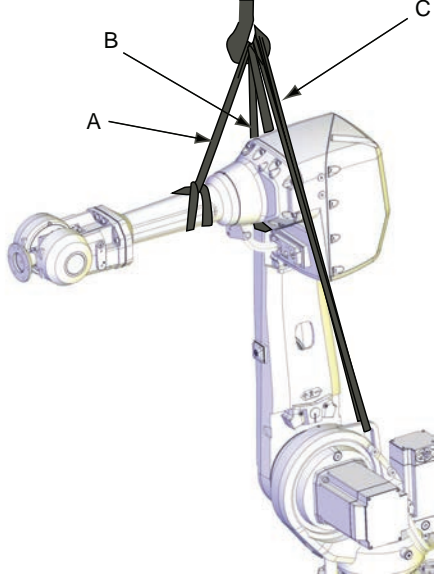
Continues on next page

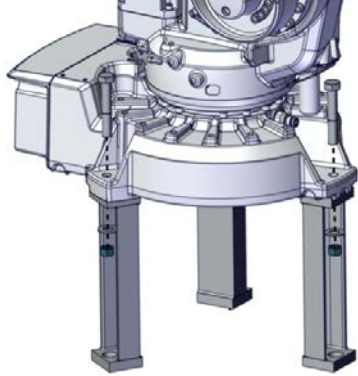

	Action	Note
7	<p>Secure the robot with <i>roundslings</i> in an overhead crane.</p> <p>Stretch the roundslings so that the robot weight is secured when removing foundation bolts in next step.</p>	<p>Dimensions are specified in <a href="#">Required equipment on page 256</a>.</p>  <p>xx1100000582</p> <ul style="list-style-type: none"> <li>A Roundsling 1.5 m</li> <li>B Roundsling 2 m</li> <li>C Roundsling 2 m</li> </ul>
8	<p> <b>CAUTION</b></p> <p>The IRB 4600 Foundry Prime robot weighs 445 kg.</p> <p>All lifting accessories used must be sized accordingly!</p>	
9	<p>Remove the bolts that secure the robot to the foundation.</p>	
10	<p>Lift the robot and fit three support legs to the robot base, using bolts, washers and nuts.</p> <p> <b>DANGER</b></p> <p>Working underneath the manipulator without safely securing the support legs between the robot base and the foundation will result in serious or fatal injury.</p> <p>Make sure the robot is stable and safely secured to the foundation via the support legs, before working underneath the robot. Keep the lifting accessories stretched for extra safety precautions.</p>	 <p>xx1800000874</p>

Continues on next page

## 4 Repair

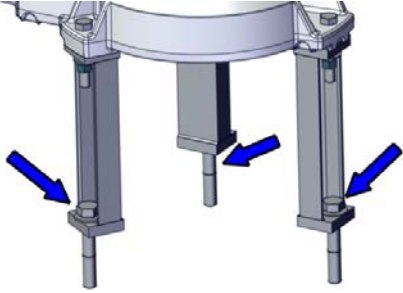

### 4.3.6 Replacing the base

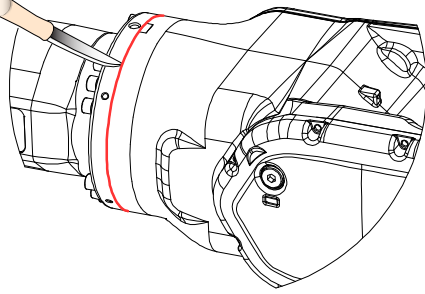
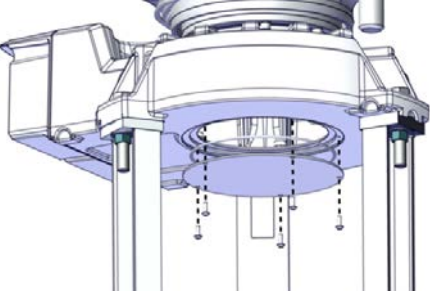
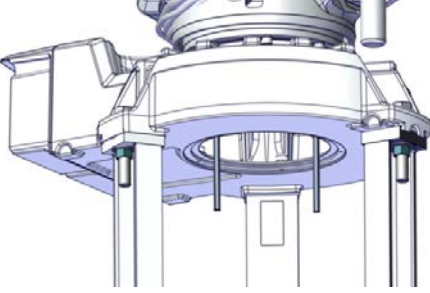
Continued

	Action	Note
11	Lower the robot and secure the support legs to the foundation, using bolts and washers.	 <p>xx1800000875</p>
12	<p><i>Foundry Prime robots:</i> Cut the paint with a knife in the joint between the motor and the structure in order to avoid that the paint cracks.</p> <p> <b>CAUTION</b></p> <p>Always cut the paint with a knife and grind the paint edge when disassembling parts. See <a href="#">Cut the paint or surface on the robot before replacing parts on page 200</a>.</p>	<p>The figure shows the principal method.</p>  <p>xx0900000121</p>
13	Remove the <i>cover plate</i> at the bottom of the base.	 <p>xx1800000879</p>
14	Remove the base attachment screws and washers.	
15	Fit two guide pins in opposite holes in the axis-1 gearbox.	<p>Guide pin, M8x150: 3HAC15520-2 Always use guide pins in pairs.</p>  <p>xx1800000883</p>

Continues on next page

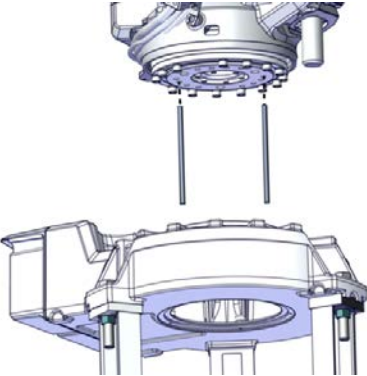

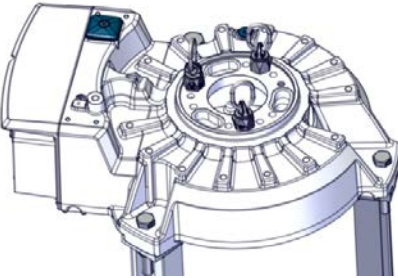
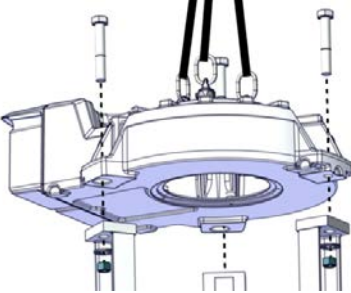
	Action	Note
16	<p> <b>CAUTION</b></p> <p>The arm system and axis-1 gearbox weighs 380 kg together. All lifting accessories must be sized accordingly.</p>	
17	<p>Lift away the robot arm system. Remove the guide pins, if the arm system is about to be laid down on the floor. See <a href="#">Illustration of robot put down on its side on page 327</a>.</p>	 <p>xx1800000884</p>
18	<p> <b>CAUTION</b></p> <p>The weight of the base is 49 kg All lifting accessories used must be sized accordingly.</p>	
19	<p>Fit three lifting eyes to the base and secure with roundslings in an overhead crane or similar.</p>	<p>Lifting eye: M8</p>  <p>xx1800000931</p>
20	<p>Remove the support legs attachments screws and remove the base from the support legs.</p>	 <p>xx1800000885</p>

Continues on next page



## 4 Repair

### 4.3.6 Replacing the base

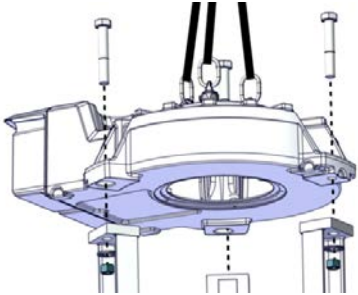

*Continued*

#### Refitting the base

Use this procedure to refit the complete arm system to the base.

	Action	Note
1	 <b>CAUTION</b> The weight of the base is 49 kg All lifting accessories used must be sized accordingly.	
2	Fit three lifting eyes to the base and secure with roundslings in an overhead crane or similar.	Lifting eye: M8
3	Fit the new base to the support legs and secure with the attachment screws.	 xx1800000885
4	Clean the joints that have been opened. See <a href="#">Cut the paint or surface on the robot before replacing parts on page 200</a>	
5	Remove residues of old Loctite and other contaminations from surfaces before applying new Loctite 574.	 <b>Tip</b> Use Loctite 7063 (or similar) for cleaning.

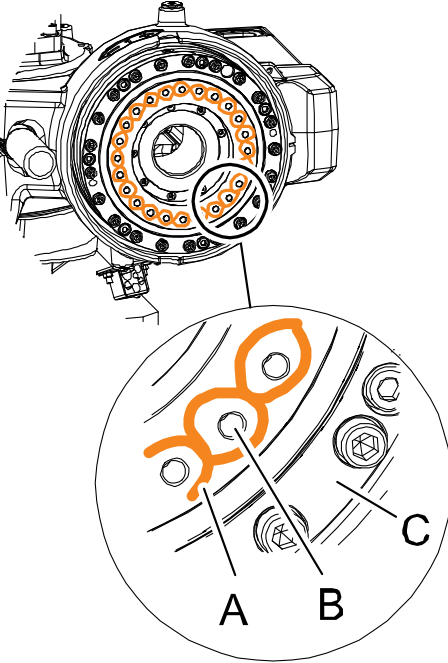
*Continues on next page*

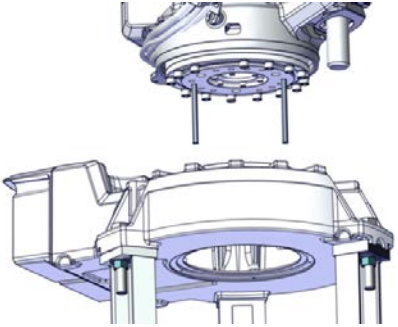

	Action	Note
6	<p>Apply <i>Loctite 574</i> around the <i>screw holes</i> on the <i>axis-1 gearbox</i> as shown in the figure.</p>	 <p>xx0800000353</p> <p><b>Parts</b></p> <ul style="list-style-type: none"> <li>A Loctite 574</li> <li>B Screw hole in axis-1 gearbox</li> <li>C Axis-1 gearbox</li> </ul>
7	<p> <b>CAUTION</b></p> <p>The arm system and axis-1 gearbox weighs 380 kg together. All lifting accessories must be sized accordingly.</p>	
8	Lift the arm system to the mounting site.	
9	Fit two guide pins in opposite holes in the axis-1 gearbox.	<p>Guide pin, M8x150: 3HAC15520-2 Always use guide pins in pairs.</p>  <p>xx1800000932</p>

Continues on next page

## 4 Repair

### 4.3.6 Replacing the base

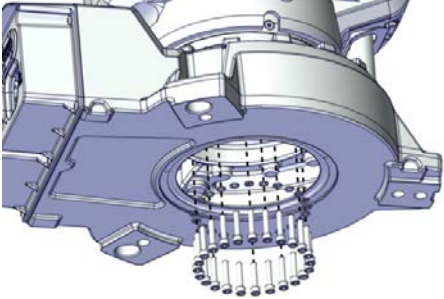
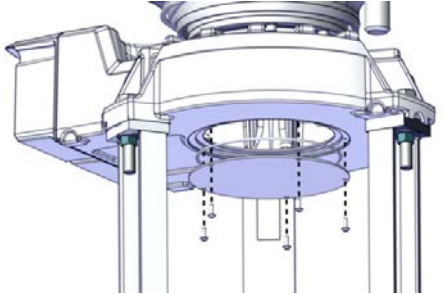
Continued

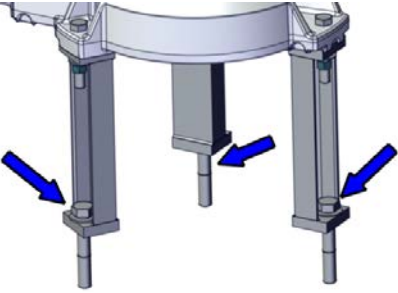
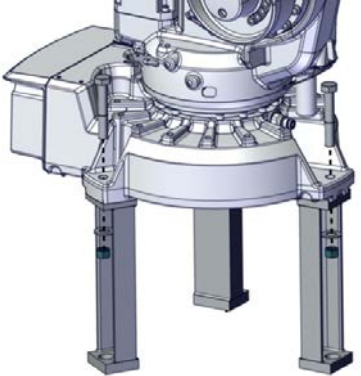
	Action	Note
10	Lower the arm system against the base and secure with the <i>attachment screws</i> and <i>washers</i> .	Attachment screws: M8x40 quality Steel 12.9 Gleitmo and washers (24+24 pcs). Tightening torque: 35 Nm.  xx1800000882
11	Apply some grease to the <i>o-ring</i> and refit the o-ring between the cover and base.	
12	Refit the <i>cover plate</i> at the bottom of the base with its attachment screws.	Attachment screws: M6x16 quality 8.8-A2F (5 pcs)  xx1800000879
13	Remove the screws that secure the support legs to the foundation.   <b>DANGER</b>  Stretch the roundslings to make sure that the robot weight is secured.	 xx1800000875
14	Lift the complete robot and remove the support legs from the base.	 xx1800000874

Continues on next page

	Action	Note
15	Lower the robot and secure it to the foundation.	See <a href="#">Orienting and securing the robot on page 68</a> .
16	Seal and paint the joints that have been opened. Also repair possible damages of the special Foundry Prime paint coat of the robot. See <a href="#">Cut the paint or surface on the robot before replacing parts on page 200</a> .	
17	Recalibrate the robot.	Pendulum Calibration is described in <i>Operating manual - Calibration Pendulum</i> , enclosed with the calibration tools. Axis Calibration is described in <a href="#">Calibrating with Axis Calibration method on page 367</a> . General calibration information is included in section <a href="#">Calibration on page 353</a> .
18	 <b>DANGER</b> Make sure all safety requirements are met when performing the first test run.	

## 4 Repair

### 4.4.1 Replacing the complete upper arm

## 4.4 Upper arm

### 4.4.1 Replacing the complete upper arm

#### Location of the complete upper arm

The complete upper arm is located as shown in the figure.

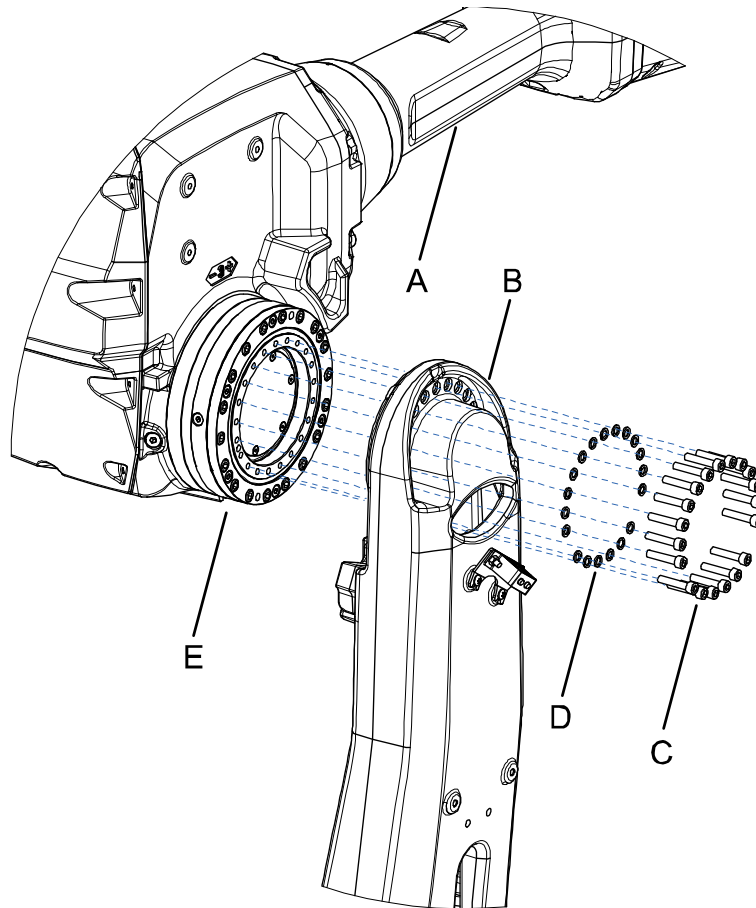

xx0800000337

A	Upper arm
B	Lower arm
C	Attachment screws M8x40 quality steel 12.9 Gleitmo (19 pcs)
D	Washers quality steel 8.4x13x1.5 (19 pcs)
E	Axis-2 gearbox

#### Required equipment

Equipment	Note
Armhouse	For spare parts no. see Spare parts - Upper arm (2.05/2.50/2.55) in Product manual, spare parts - IRB 2600.

Continues on next page

### 4.4.1 Replacing the complete upper arm Continued

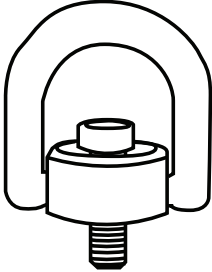
Equipment	Note
Tubular shaft unit	For spare parts no. see Spare parts - Upper arm (2.05/2.50/2.55) in Product manual, spare parts - IRB 2600.
Rotating lifting point	<p>2 pcs. Dimension: M8. Example: Gunnebo RLP GrabiQ M8-10.</p>  <p>xx1100000564</p>
Washer	<p>Required if the screw in the rotating lifting point bottoms. Inner diameter: 12 mm. Outer diameter: min. 23 mm. Thickness: enough to prevent the screw in the rotating lifting point to bottom.</p>
Roundslings	<p>3 pcs. Length: 1.5 m. Lifting capacity: 500 kg.</p>
Screws	<p>2 pcs. Used to prevent the roundsling at the wrist from sliding. Dimension: • M8. Length: 70 mm. Quality: 8.8. (IRB 4600 - 60/2.05)</p>
Guide pins	M8 (2 pcs)
Standard toolkit	Content is defined in section <a href="#">Standard tools on page 398</a> .
Other tools and procedures may be required. See references to these procedures in the step-by-step instructions below.	These procedures include references to the tools required.

#### Additional equipment - Foundry Prime

Equipment	Art. no.	Note
Rust preventive	3HAC034903-001	Mercasol
Sikaflex 521FC	3HAC026759-001	
Loctite 574	12340011-116	
Brush		
Foundry Prime touch up kit	3HAC035355-001	

Continues on next page

## 4 Repair

### 4.4.1 Replacing the complete upper arm

*Continued*

#### Deciding calibration routine

Decide which calibration routine to be used, based on the information in the table. Depending on which routine is chosen, action might be required prior to beginning the repair work of the robot, see the table.

	Action	Note
1	<p>Decide which calibration routine to use for calibrating the robot.</p> <ul style="list-style-type: none"> <li>Reference calibration. External cable packages (DressPack) and tools can stay fitted on the robot.</li> <li>Fine calibration. All external cable packages (DressPack) and tools must be removed from the robot.</li> </ul>	
	<p><b>If the robot is to be calibrated with reference calibration:</b></p> <p>Find previous reference values for the axis or create new reference values. These values are to be used after the repair procedure is completed, for calibration of the robot.</p> <p>If no previous reference values exist, and no new reference values can be created, then reference calibration is not possible.</p>	<p>Follow the instructions given in the reference calibration routine on the FlexPendant to create reference values.</p> <p>Creating new values requires possibility to move the robot.</p> <p>Read more about reference calibration for Axis Calibration in <a href="#">Reference calibration routine on page 368</a>.</p> <p>Read more about reference calibration for Pendulum Calibration in <i>Operating manual - Calibration Pendulum</i>.</p>
	<p><b>If the robot is to be calibrated with fine calibration:</b></p> <p>Remove all external cable packages (DressPack) and tools from the robot.</p>	



#### CAUTION

Always cut the paint with a knife and grind the paint edge when disassembling parts. See [Cut the paint or surface on the robot before replacing parts on page 200](#).





#### Removing the complete upper arm

Use this procedure to remove the complete upper arm. This procedure can be done without draining the axis 3 gearbox.

	Action	Note
1	Decide which calibration routine to use, and take actions accordingly prior to beginning the repair procedure.	
2	<p>Run the robot to the position shown in the figure.</p> <p>The robot must be floor mounted and the upper arm must be horizontally positioned.</p>	 <p>xx0800000336</p>

*Continues on next page*



	Action	Note
3	 <b>DANGER</b> Turn off all: <ul style="list-style-type: none"> <li>• electric power supply</li> <li>• hydraulic pressure supply</li> </ul> to the robot, before entering the robot working area.	
4	 <b>CAUTION</b> The weight of the complete upper arm (including the wrist) is 140 kg All lifting accessories used must be sized accordingly.	
5	Attach the lifting accessories to the upper arm.	See <a href="#">Attaching the lifting accessories to the upper arm on page 271</a> .
6	Unload the weight of the upper arm by stretching the roundslings.   <b>Tip</b>  Turn on the power temporarily and release the brakes of axis 3 to rest the weight onto the roundslings.	
7	 <b>DANGER</b> Turn off all: <ul style="list-style-type: none"> <li>• electric power supply</li> <li>• hydraulic pressure supply</li> </ul> to the robot, before entering the robot working area.	
8	 <b>CAUTION</b> Always cut the paint with a knife and grind the paint edge when disassembling parts. See <a href="#">Cut the paint or surface on the robot before replacing parts on page 200</a> .	
9	Disconnect all <i>motor cables</i> from motors axes 3, 4, 5 and 6.	How to disconnect cables from motors is detailed in sections: <ul style="list-style-type: none"> <li>• <a href="#">Removing motors on page 304</a></li> </ul>

Continues on next page

## 4 Repair

### 4.4.1 Replacing the complete upper arm

Continued

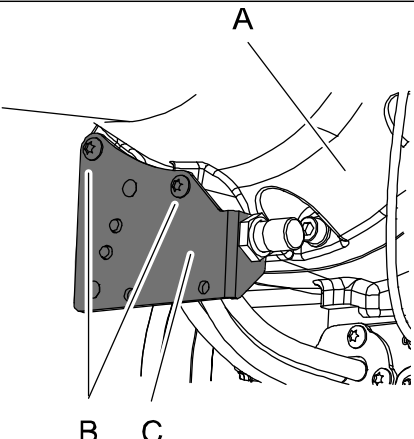
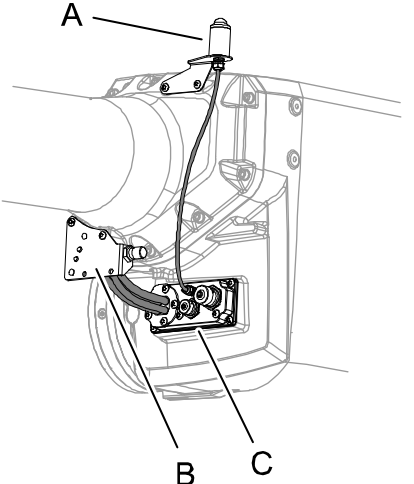
	Action	Note
10	Remove the <i>bracket</i> fitted on the tubular shaft unit.	 <p>xx0800000335</p> <p>Parts:</p> <ul style="list-style-type: none"><li>• A: Tubular shaft unit</li><li>• B: Attachment screws M6x16 quality 8.8-A2F (2 pcs)</li><li>• C: Bracket</li></ul>
11	Remove the <i>signal lamp</i> , if used.	
12	Remove the <i>cable bracket</i> on the armhouse.	 <p>xx0800000338</p> <p>Parts:</p> <ul style="list-style-type: none"><li>• A: Signal lamp</li><li>• B: Bracket</li><li>• C: Cable bracket</li></ul>
13	Using caution, pull the cable package out of the hole where the cable bracket was fitted.	
14	Stop the air from the Foundry Prime air hose. Insert a screw in the hose and a lock it with a hose clamp.	

Continues on next page

## 4.4.1 Replacing the complete upper arm Continued

	Action	Note
15	Remove the <i>attachment screws</i> securing the upper arm to the lower arm.	See the figure in: <ul style="list-style-type: none"> <li>• <a href="#">Location of the complete upper arm on page 266</a></li> </ul>  <b>Note</b> Do not remove the attachment screws securing the gearbox axis 3 to the arm-house!
16	Remove the complete upper arm.	

### Attaching the lifting accessories to the upper arm

#### Attaching the lifting accessories

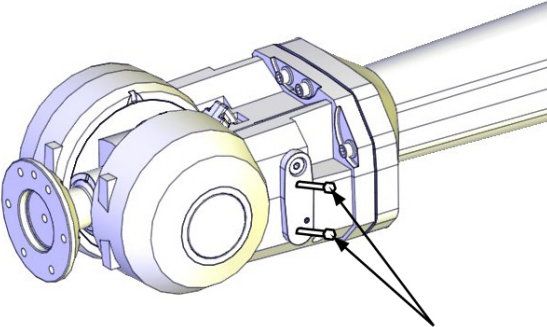
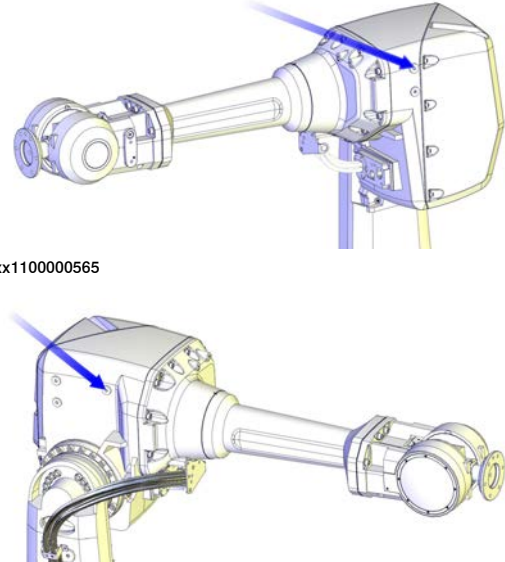
	Action	Note
1	Fit two <i>screws</i> in the wrist unit. The purpose of these screws is to prevent the roundsling from sliding.	Dimension is specified in <a href="#">Required equipment on page 266</a> .  <small>xx1100000568</small>
2	Fit two <i>rotating lifting points</i> to the attachment holes in the arm house, see the figure. Secure the lifting point tightly against the arm house, but at the same time making sure that the screw does not bottom. Use an extra <i>washer</i> if the screw does bottom. Tightening torque: 30 Nm.	Dimension is specified in <a href="#">Required equipment on page 266</a> .  <small>xx1100000565</small> <small>xx1100000566</small>

Continues on next page

## 4 Repair

### 4.4.1 Replacing the complete upper arm

Continued

	Action	Note
3	Run a <i>roundsling</i> through each rotating lifting point and fasten both ends at the lifting hook.	Dimension is specified in <a href="#">Required equipment on page 266</a> . See figure <a href="#">Attaching the roundslings to the upper arm on page 272</a> .
4	Make a loop of the third <i>roundsling</i> , running it around the wrist unit. Run the roundsling on both sides of the screws and fasten the free end of the roundsling to the lifting hook.	Dimension is specified in <a href="#">Required equipment on page 266</a> . See figure <a href="#">Attaching the roundslings to the upper arm on page 272</a> .

#### Attaching the roundslings to the upper arm

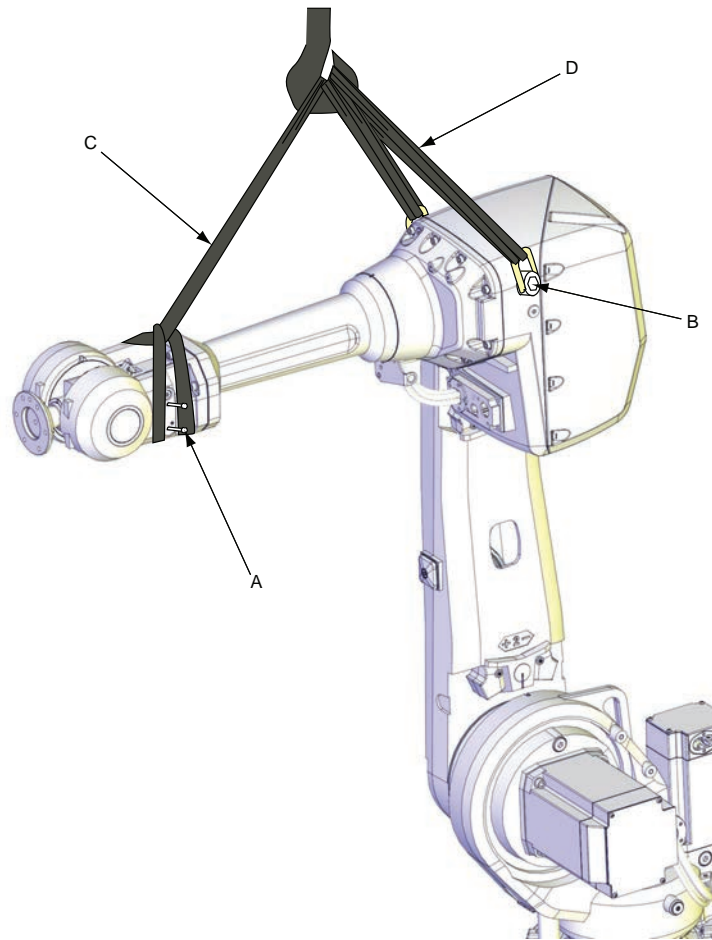





xx110000567

A	Screws to prevent the roundsling from sliding, 2 pcs
B	Rotating lifting point, 2 pcs
C	Roundsling around wrist unit Length: 1.5 m.
D	Roundsling attached to arm house, 2 pcs Length: 1.5 m.

Continues on next page

## Refitting the complete upper arm

Use this procedure to refit the complete upper arm.

	Action	Note
1	 <b>DANGER</b> Turn off all: <ul style="list-style-type: none"> <li>• electric power supply</li> <li>• hydraulic pressure supply</li> </ul> to the robot, before entering the robot working area.	
2	Clean the joints that have been opened. See <a href="#">Cut the paint or surface on the robot before replacing parts on page 200</a>	
3	 <b>Note</b> Do not remove the attachment screws securing the gearbox axis 3 to the armhouse!	
4	 <b>CAUTION</b> The weight of the complete upper arm (including the wrist) is 140 kg All lifting accessories used must be sized accordingly.	
5	Clean all assembly surfaces.	
6	Attach the lifting accessories to the upper arm.	See <a href="#">Attaching the lifting accessories to the upper arm on page 271</a> .
7	Fit <i>guide pins</i> to the upper arm.	Specified in <a href="#">Required equipment on page 266</a> .
8	Lift the upper arm to the robot using an overhead crane.	
9	Release the brakes of the axis 3 motor.	
10	Refit the upper arm to the lower arm with its <i>attachment screws</i> .  <b>Note</b> Use new attachment screws! It may be necessary to turn the gear by rotating the motor pinion with a <i>rotation tool</i> , <i>motor</i> beneath the motor cover.	See the figure in: <ul style="list-style-type: none"> <li>• <a href="#">Location of the complete upper arm on page 266</a></li> </ul> Tightening torque : <ul style="list-style-type: none"> <li>• 35 Nm</li> </ul>

Continues on next page

## 4 Repair

### 4.4.1 Replacing the complete upper arm

Continued

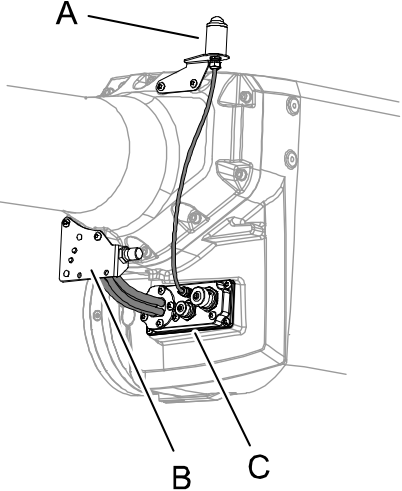
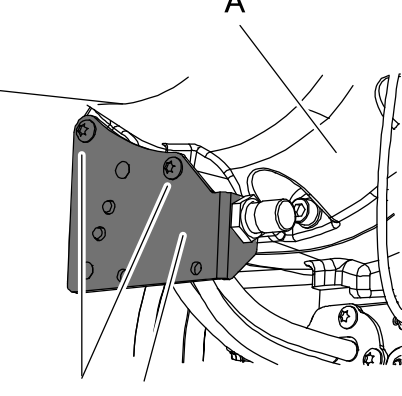
	Action	Note
11	Using caution, push the cable package through the hole where the cable bracket will be fitted.	 <p>xx0800000338</p> <p>Parts:</p> <ul style="list-style-type: none"> <li>• A: Signal lamp</li> <li>• B: Bracket</li> <li>• C: Cable bracket</li> </ul>
12	Refit the air hose to the elbow fitting.	
13	Refit the <i>cable bracket</i> with its attachment screws.	
14	Reconnect all <i>motor cables</i> .	<p>How to connect motor cables is detailed in sections:</p> <ul style="list-style-type: none"> <li>• <a href="#">Refitting motors on page 313</a></li> </ul>
15	Refit the <i>bracket</i> on the <i>tubular shaft unit</i> .	 <p>xx0800000335</p> <p>Parts:</p> <ul style="list-style-type: none"> <li>• A: Tubular shaft unit</li> <li>• B: Attachment screws M6x16 quality 8.8-A2F (2 pcs)</li> <li>• C: Bracket</li> </ul>
16	Refit the <i>signal lamp</i> , if used.	
17	Seal and paint the joints that have been opened. Also repair possible damages of the special Foundry Prime paint coat of the robot. See <a href="#">Cut the paint or surface on the robot before replacing parts on page 200</a> .	

Continues on next page

4.4.1 Replacing the complete upper arm  
*Continued*

	Action	Note
18	Recalibrate the robot.	Pendulum Calibration is described in <i>Operating manual - Calibration Pendulum</i> , enclosed with the calibration tools. Axis Calibration is described in <a href="#">Calibrating with Axis Calibration method on page 367</a> . General calibration information is included in section <a href="#">Calibration on page 353</a> .
19	 <b>DANGER</b> Make sure all safety requirements are met when performing the first test run.	

## 4 Repair

### 4.4.2 Replacing complete tubular shaft unit

### 4.4.2 Replacing complete tubular shaft unit

#### Location of tubular shaft unit

The tubular shaft unit is located as shown in the figure.

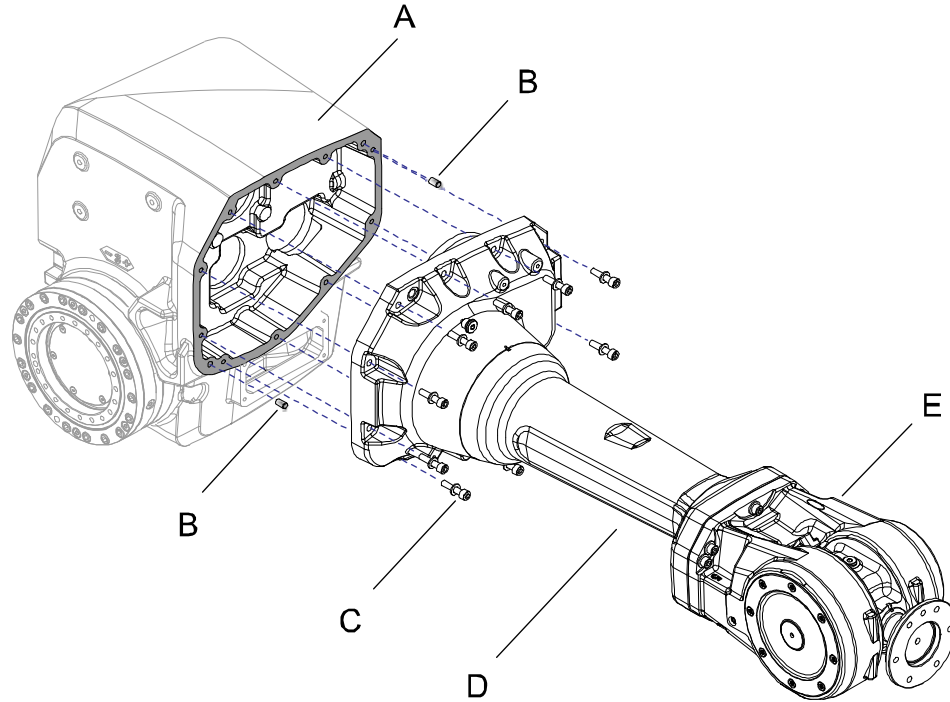

xx080000334

A	Armhouse
B	Parallel pin, hardened 8x16 m6 (2 pcs)
C	Attachment screws M8x35 quality 8.8-A2F and washers (10 + 10 pcs)
D	Tubular shaft unit
E	Wrist unit

#### Required equipment

Equipment	Note
Tubular shaft unit	For spare parts no. see Spare parts - Upper arm (2.05/2.50/2.55) in Product manual, spare parts - IRB 2600.
Guide pins	2 pcs. Dimension: M8.
Cleaning agent	Isopropanol
Sealing liquid	Loctite 574
Standard toolkit	Content is defined in section <a href="#">Standard tools on page 398</a> .
Other tools and procedures may be required. See references to these procedures in the step-by-step instructions below.	These procedures include references to the tools required.

Continues on next page



## Additional equipment - Foundry Prime

Equipment	Art. no.	Note
Rust preventive	3HAC034903-001	Mercasol
Sikaflex 521FC	3HAC026759-001	
Loctite 574	12340011-116	
Brush		
Foundry Prime touch up kit	3HAC035355-001	

## Deciding calibration routine

Decide which calibration routine to be used, based on the information in the table. Depending on which routine is chosen, action might be required prior to beginning the repair work of the robot, see the table.

	Action	Note
1	Decide which calibration routine to use for calibrating the robot. <ul style="list-style-type: none"> <li>Reference calibration. External cable packages (DressPack) and tools can stay fitted on the robot.</li> <li>Fine calibration. All external cable packages (DressPack) and tools must be removed from the robot.</li> </ul>	
	<p><b>If the robot is to be calibrated with reference calibration:</b></p> <p>Find previous reference values for the axis or create new reference values. These values are to be used after the repair procedure is completed, for calibration of the robot.</p> <p>If no previous reference values exist, and no new reference values can be created, then reference calibration is not possible.</p>	<p>Follow the instructions given in the reference calibration routine on the FlexPendant to create reference values.</p> <p>Creating new values requires possibility to move the robot.</p> <p>Read more about reference calibration for Axis Calibration in <a href="#">Reference calibration routine on page 368</a>.</p> <p>Read more about reference calibration for Pendulum Calibration in <i>Operating manual - Calibration Pendulum</i>.</p>
	<p><b>If the robot is to be calibrated with fine calibration:</b></p> <p>Remove all external cable packages (DressPack) and tools from the robot.</p>	

## Removing complete tubular shaft unit

Use this procedure to remove the complete tubular shaft unit.



	Action	Note
1	Decide which calibration routine to use, and take actions accordingly prior to beginning the repair procedure.	
2	Drain <i>oil</i> from gearbox axis 4.	<p>How to drain the oil from the gearbox is described in section:</p> <ul style="list-style-type: none"> <li><a href="#">Changing the oil, axis-4 gearbox on page 175</a></li> </ul>

Continues on next page





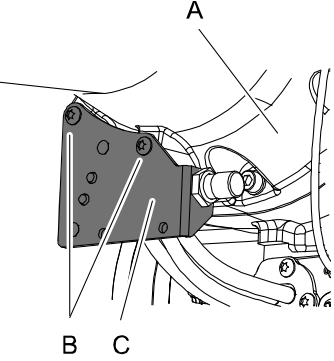

## 4 Repair

### 4.4.2 Replacing complete tubular shaft unit

Continued

	Action	Note
3	Move the robot to the position shown in the figure.	 <p>xx0800000336</p>
4	 <p><b>DANGER</b></p> <p>Turn off all:</p> <ul style="list-style-type: none"> <li>• electric power supply</li> <li>• hydraulic pressure supply</li> </ul> <p>to the robot, before entering the robot working area.</p>	
5	 <p><b>CAUTION</b></p> <p>Always cut the paint with a knife and grind the paint edge when disassembling parts. See <a href="#">Cut the paint or surface on the robot before replacing parts on page 200</a>.</p>	
6	Remove the <i>bracket</i> securing the cable package to the tubular shaft unit by removing its attachment screws.	 <p>xx0800000335</p> <p><b>Parts:</b></p> <ul style="list-style-type: none"> <li>• A: Tubular shaft unit</li> <li>• B: Attachment screws M6x16 quality 8.8-A2F (2 pcs)</li> <li>• C: Bracket</li> </ul>
7	Place the cable package in a way that it will not be damaged in the continued removal procedure.	
8	Remove motors axes 4, 5 and 6.	<p>How to remove motors is described in section:</p> <ul style="list-style-type: none"> <li>• <a href="#">Removing motors on page 304</a></li> </ul>

Continues on next page

	Action	Note
9	 <b>Tip</b> If only the tubular shaft unit shall be replaced, it is a good idea to remove the <i>wrist unit</i> at this stage.	How to remove the wrist unit is detailed in section: <ul style="list-style-type: none"> <li>• <a href="#">Removal of wrist unit on page 284</a></li> </ul>
10	 <b>CAUTION</b> The robot arm tube weighs 65 kg. All lifting accessories used must be sized accordingly.	
11	Secure the <i>tubular shaft unit</i> with roundslings in an overhead crane.   <b>CAUTION</b> Prevent the slings from sliding! For example a small plate can be fitted to the lower attachment hole for the cable bracket (removed in a previous step). The plate should be fitted so it points downwards and functions as a mechanical stop for the roundslings. At the other end of the tubular shaft unit, a shackle can be fitted if the wrist unit is removed.	
12	Remove the <i>attachment screws</i> that secure the tubular shaft unit.	See the figure in: <ul style="list-style-type: none"> <li>• <a href="#">Location of tubular shaft unit on page 276</a></li> </ul>
13	Remove the <i>tubular shaft unit</i> using caution. The tubular shaft unit is fitted with Loctite.   <b>CAUTION</b> Do not damage the gears when removing the tubular shaft unit.   <b>CAUTION</b> Remaining oil will drain out from the gear-box cavity when the tubular shaft is lifted out.	 <b>Note</b> There are two parallel pins guiding the tubular shaft unit into its place. See figure in <a href="#">Replacing complete tubular shaft unit on page 276</a> .



## 4 Repair

### 4.4.2 Replacing complete tubular shaft unit

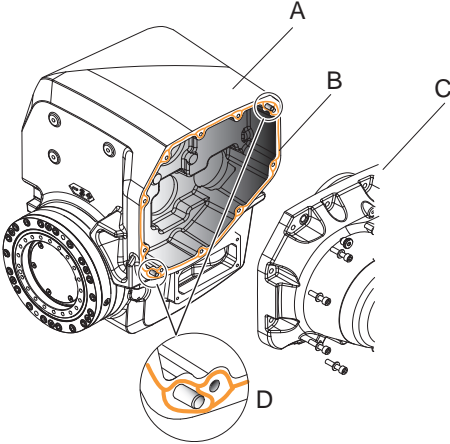

*Continued*

#### Refitting complete tubular shaft unit

Use this procedure to refit the tubular shaft unit.

	Action	Note
1	 <p><b>DANGER</b></p> <p>Turn off all:</p> <ul style="list-style-type: none"> <li>• electric power supply</li> <li>• hydraulic pressure supply</li> </ul> <p>to the robot, before entering the robot working area.</p>	
2	<p>Clean the joints that have been opened. See <a href="#">Cut the paint or surface on the robot before replacing parts on page 200</a></p>	
3	<p>Remove residues of old Loctite and other contaminations from the assembly surfaces. Remove any painting from the assembly surfaces, with a knife.</p>	
4	<p>Apply sealing liquid (Loctite 574) on the surface between the tubular shaft unit and the armhouse.</p> <p>Make sure to apply the sealing liquid in circles around each of the attachment holes.</p>	 <p>xx0800000457</p> <p>Parts:</p> <ul style="list-style-type: none"> <li>A Armhouse</li> <li>B Surface where Loctite 574 shall be applied</li> <li>C Tubular shaft unit</li> <li>D Cylindrical pin (2 pcs)</li> </ul>
5	 <p><b>CAUTION</b></p> <p>The robot arm tube weighs 65 kg. All lifting accessories used must be sized accordingly!</p>	

*Continues on next page*

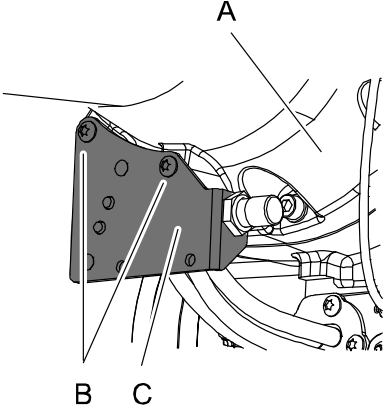
	Action	Note
6	Secure the tubular shaft unit with a roundsliding in an overhead crane.   <b>CAUTION</b>  Prevent the slings from sliding! For example a small plate can be fitted to the lower attachment hole for the cable bracket (removed in a previous step). The plate should be fitted so it points downwards and functions as a mechanical stop for the roundsliding. At the other end of the tubular shaft unit, a shackle can be fitted if the wrist unit is removed.	
7	Fit <i>guide pins</i> in the upper arm house.	Specified in <a href="#">Required equipment on page 276</a> .
8	Refit the tubular shaft unit, using caution.   <b>CAUTION</b>  Do not damage the gears when refitting the tubular shaft unit.	 <b>Note</b>  There are two parallel pins guiding the tubular shaft unit into its place.
9	Secure the tubular shaft unit with its <i>attachment screws</i> .	See the figure in: <ul style="list-style-type: none"> <li>• <a href="#">Location of tubular shaft unit on page 276</a></li> </ul> Tightening torque: 22 Nm
10	Refit <i>motors axes 4, 5 and 6</i> .	How to refit motors is described in section: <ul style="list-style-type: none"> <li>• <a href="#">Refitting motors on page 313</a></li> </ul>
11	Perform a leak-down test.	See <a href="#">Performing a leak-down test on page 194</a> .
12	Refit the <i>bracket</i> securing the cable package to the tubular shaft unit, with its <i>attachment screws</i> .	 <p>xx0800000335</p> <b>Parts:</b> <ul style="list-style-type: none"> <li>• A: Tubular shaft unit</li> <li>• B: Attachment screws M6x16 quality 8.8-A2F (2 pcs)</li> <li>• C: Bracket</li> </ul>

Continues on next page

## 4 Repair

### 4.4.2 Replacing complete tubular shaft unit

Continued

	Action	Note
13	If the <i>wrist unit</i> has been removed from the tubular shaft unit, refit it now.	How to refit the wrist unit is detailed in section: <ul style="list-style-type: none"><li>• <a href="#">Refitting of wrist unit on page 285</a></li></ul>
14	Refill gearbox axis 4 with oil.	How to refill oil in gearbox is described in section: <ul style="list-style-type: none"><li>• <a href="#">Changing the oil, axis-4 gearbox on page 175</a></li></ul>
15	Recalibrate the robot.	Pendulum Calibration is described in <i>Operating manual - Calibration Pendulum</i> , enclosed with the calibration tools. Axis Calibration is described in <a href="#">Calibrating with Axis Calibration method on page 367</a> . General calibration information is included in section <a href="#">Calibration on page 353</a> .
16	Seal and paint the joints that have been opened. Also repair possible damages of the special Foundry Prime paint coat of the robot. See <a href="#">Cut the paint or surface on the robot before replacing parts on page 200</a> .	
17	 <b>DANGER</b> Make sure all safety requirements are met when performing the first test run.	

### 4.4.3 Replacing wrist unit

#### Location of wrist unit

The wrist unit is located in the upper arm as shown in the figures.

IRB 4600 -60/2.05

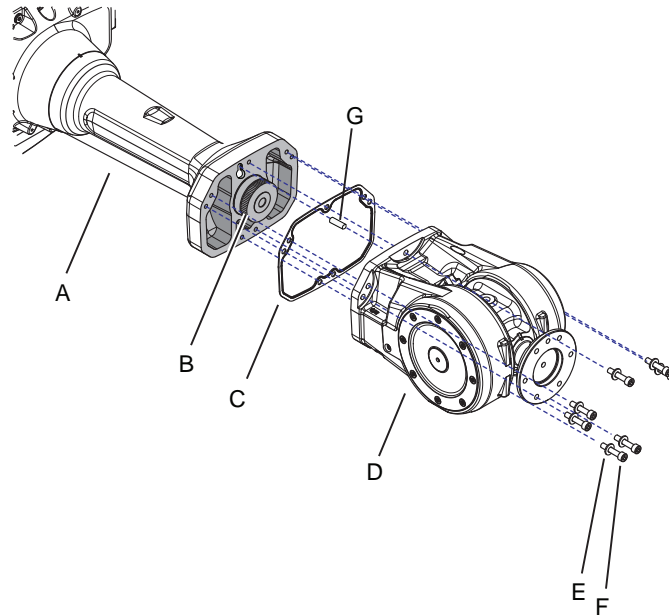

xx0800000333

A	Upper arm
B	Gear
C	O-ring/sealing plate
D	Wrist unit
E	Spring washer, conical 8.4x18x2, quality steel-mZn12c (7 pcs)
F	Attachment screw M8x40, quality steel 12.9 Gleitmo (7 pcs)
G	Guide pin (only available for robots that are calibrated with Axis Calibration)

#### Required equipment

Equipment	Note
Wrist unit	For spare parts no. see Spare parts - Upper arm (2.05/2.50/2.55) in Product manual, spare parts - IRB 2600.
O-ring Sealing	For spare parts no. see Spare parts - Upper arm (2.05/2.50/2.55) in Product manual, spare parts - IRB 2600.
Measuring tool	For adjusting the play.
Standard toolkit	Content is defined in section <a href="#">Standard tools on page 398</a> .

Continues on next page

## 4 Repair

### 4.4.3 Replacing wrist unit

Continued

Equipment	Note
Other tools and procedures may be required. See references to these procedures in the step-by-step instructions below.	These procedures include references to the tools required.

#### Additional equipment - Foundry Prime

Equipment	Art. no.	Note
Rust preventive	3HAC034903-001	Mercasol
Sikaflex 521FC	3HAC026759-001	
Loctite 574	12340011-116	
Brush		
Foundry Prime touch up kit	3HAC035355-001	

#### Deciding calibration routine

Decide which calibration routine to be used, based on the information in the table. Depending on which routine is chosen, action might be required prior to beginning the repair work of the robot, see the table.

	Action	Note
1	Decide which calibration routine to use for calibrating the robot. <ul style="list-style-type: none"><li>Reference calibration. External cable packages (DressPack) and tools can stay fitted on the robot.</li><li>Fine calibration. All external cable packages (DressPack) and tools must be removed from the robot.</li></ul>	
	<b>If the robot is to be calibrated with reference calibration:</b> Find previous reference values for the axis or create new reference values. These values are to be used after the repair procedure is completed, for calibration of the robot. If no previous reference values exist, and no new reference values can be created, then reference calibration is not possible.	Follow the instructions given in the reference calibration routine on the FlexPendant to create reference values. Creating new values requires possibility to move the robot. Read more about reference calibration for Axis Calibration in <a href="#">Reference calibration routine on page 368</a> . Read more about reference calibration for Pendulum Calibration in <i>Operating manual - Calibration Pendulum</i> .
	<b>If the robot is to be calibrated with fine calibration:</b> Remove all external cable packages (DressPack) and tools from the robot.	





#### Removal of wrist unit

Use this procedure to remove the wrist unit.

	Action	Note
1	Decide which calibration routine to use, and take actions accordingly prior to beginning the repair procedure.	

Continues on next page



	Action	Note
2	 <b>DANGER</b> Turn off all: <ul style="list-style-type: none"> <li>• electric power supply</li> <li>• hydraulic pressure supply</li> </ul> to the robot, before entering the robot working area.	
3	Drain <i>oil</i> from gearbox axes 5-6.	How to drain the oil from gearbox axes 5-6 is described in section: <ul style="list-style-type: none"> <li>• <a href="#">Changing oil, axes-5 and -6 gearboxes on page 179</a></li> </ul>
4	 <b>CAUTION</b> The robot wrist unit weighs 25 kg (IRB 4600 - 60/2.05, - 45/2.05, -40/2.55) and 15 kg (IRB 4600 - 20/2.50). All lifting accessories used must be sized accordingly!	
5	Secure the wrist unit with a roundsling in an overhead crane or similar.	
6	 <b>CAUTION</b> Always cut the paint with a knife and grind the paint edge when disassembling parts. See <a href="#">Cut the paint or surface on the robot before replacing parts on page 200</a> .	
7	Remove the <i>attachment screws</i> and carefully remove the wrist unit.   <b>CAUTION</b> Do not damage the gears.	See the figure in: <ul style="list-style-type: none"> <li>• <a href="#">Location of wrist unit on page 283</a></li> </ul>

### Refitting of wrist unit

Use this procedure to refit the wrist unit.



	Action	Note
1	 <b>DANGER</b> Turn off all: <ul style="list-style-type: none"> <li>• electric power supply</li> <li>• hydraulic pressure supply</li> </ul> to the robot, before entering the robot working area.	
2	Clean the joints that have been opened. See <a href="#">Cut the paint or surface on the robot before replacing parts on page 200</a>	

Continues on next page

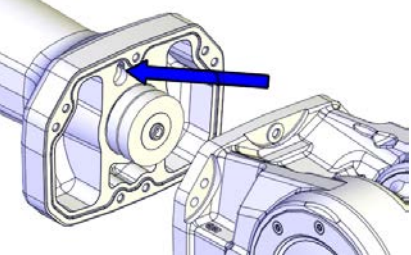

## 4 Repair

### 4.4.3 Replacing wrist unit

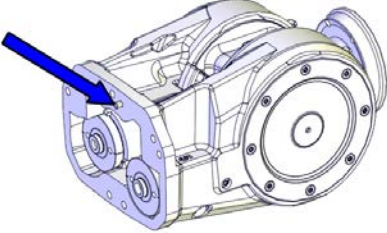
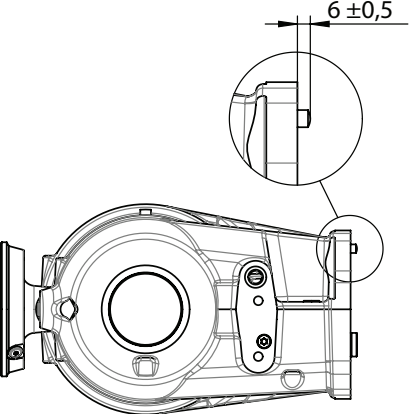
Continued

	Action	Note
3	<p>Check if there is a parallel pin hole in the upper arm tube. The hole is available on robots that are calibrated with the Axis Calibration method.</p>	 <p>xx1600000690</p>
4	<p>If there is a hole, fit the parallel pin into the corresponding hole in the wrist (enclosed with the new wrist spare part).</p> <p> <b>Note</b></p> <p>If the parallel pin is not installed on a robot calibrated with Axis Calibration, the calibration result will be affected negatively.</p>	 <p>xx1600000689</p> <p>Verify that the parallel pin sticks out from the wrist according to the measurement given below. IRB 4600 -60/2.05</p>  <p>xx1600000702</p>
5	<p>Clean all assembly surfaces. Remove any painting from the assembly surfaces with a knife.</p>	

Continues on next page

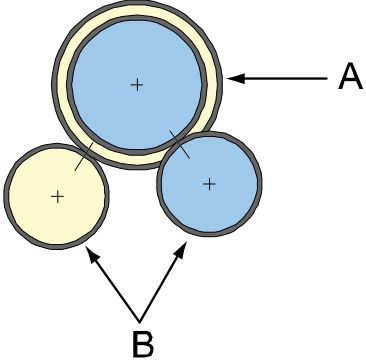
	Action	Note
6	Check the o-ring or sealing. Replace if damaged.	See the figure in: <ul style="list-style-type: none"> <li>• <a href="#">Location of wrist unit on page 283</a></li> </ul>
7	Prepare the refitting of the wrist by inserting the attachment screws and washers in the upper arm tube.	
8	<p> <b>CAUTION</b></p> <p>The robot wrist unit weighs 25 kg (IRB 4600 - 60/2.05, - 45/2.05, -40/2.55) and 15 kg (IRB 4600 - 20/2.50).</p> <p>All lifting accessories used must be sized accordingly.</p>	
9	<p>Carefully put the <i>wrist unit</i> in its place on the <i>upper arm</i>.</p> <p> <b>CAUTION</b></p> <p>Do not damage the gears.</p> <p> <b>CAUTION</b></p> <p>Make sure that the o-ring stays in place on the wrist unit.</p>	
10	<p>Adjust the play of the wrist by following these steps:</p> <ul style="list-style-type: none"> <li>• Fit the <i>measuring tool</i> at the rear of the motor.</li> <li>• Push the wrist as shown in the figure to locate the smallest play in the same way as for adjustment of motors for axes 4, 5 and 6. See <a href="#">Refitting motors on page 313</a>.</li> </ul>	 <p>xx1000000223</p> <p>Parts:</p> <ul style="list-style-type: none"> <li>• A: Gears on drive shaft unit, axes 5-6</li> <li>• B: Gears on the wrist</li> </ul>
11	Secure the wrist unit with its <i>attachment screws</i> and <i>washers</i> .	<p>See the figure in</p> <ul style="list-style-type: none"> <li>• <a href="#">Location of wrist unit on page 283</a></li> </ul> <p>Tightening torque: 35 Nm.</p>
12	<i>Measure the play</i> by moving axes 5 and 6 with the measuring tool.	<p>How to measure the play is described in sections:</p> <ul style="list-style-type: none"> <li>• <a href="#">Measuring the play, axis 5 on page 289</a></li> <li>• <a href="#">Measuring the play, axis 6 on page 291</a></li> </ul>
13	Perform a leak-down test.	See <a href="#">Performing a leak-down test on page 194</a> .

Continues on next page

## 4 Repair

### 4.4.3 Replacing wrist unit

Continued

	Action	Note
14	Refill <i>oil</i> in gearbox axes 5-6.	How to fill oil in gearbox axes 5-6 is described in section: <ul style="list-style-type: none"><li>• <a href="#">Changing oil, axes-5 and -6 gearboxes on page 179</a></li></ul>
15	Seal and paint the joints that have been opened. Also repair possible damages of the special Foundry Prime paint coat of the robot. See <a href="#">Cut the paint or surface on the robot before replacing parts on page 200</a> .	
16	Re-calibrate the robot.	Pendulum Calibration is described in <i>Operating manual - Calibration Pendulum</i> , enclosed with the calibration tools. Axis Calibration is described in <a href="#">Calibrating with Axis Calibration method on page 367</a> . General calibration information is included in section <a href="#">Calibration on page 353</a> .
17	 <b>DANGER</b> Make sure all safety requirements are met when performing the first test run.	

## 4.4.4 Measuring the play, axis 5

### General

After reassembly due to repair work or any other reason, the play in axis 5 and 6 must be checked to ensure the repetition accuracy of the robot positioning. The procedure for axis 5 is detailed below.

### Required equipment

Equipment, etc.	Article number	Note
Standard toolkit	-	Content is defined in section <a href="#">Standard tools on page 398</a> .
Measuring tool, play (IRB 4600 -60/2.05)	3HAB1611-6	
Other tools and procedures may be required. See references to these procedures in the step-by-step instructions below.		These procedures include references to the tools required.

### Additional equipment - Foundry Prime

Equipment	Article number	Note
Rust preventive	3HAC034903-001	Mercasol
Sikaflex 521FC	3HAC026759-001	
Loctite 574	12340011-116	
Brush		
Foundry Prime touch up kit	3HAC035355-001	

### Measurement, axis 5

The procedure below details how to measure the play of axis 5.



#### Note

The measuring tool and measuring values differ depending on robot version.

	Action	Information
1	<b>DANGER</b> Turn off all: <ul style="list-style-type: none"> <li>• electric power supply</li> <li>• hydraulic pressure supply</li> </ul> to the robot, before entering the robot working area.	
2	Move the robot to calibration position and turn the axis 4 90°.	
3	Fit the <i>measuring tool, play</i> to the turning disc.	Article number is specified in <a href="#">Required equipment on page 289</a> .

*Continues on next page*

## 4 Repair

### 4.4.4 Measuring the play, axis 5

Continued

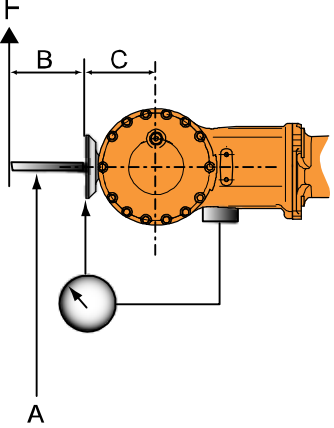
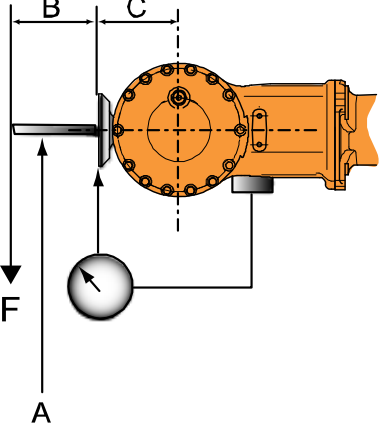
	Action	Information
4	Apply load F in one direction, as shown in the figure to the right.  <b>Note</b> Different load and distances for the different robot versions, as specified to the right!	 <p>xx0300000186</p> <p><b>Values for IRB 4600 - 60/2.05</b></p> <ul style="list-style-type: none"> <li>• A: Measuring tool, play</li> <li>• B: 207.5 mm</li> <li>• C: 135 mm</li> <li>• F: 90N</li> </ul>
5	Remove the load and set the dial indicator to zero.	
6	Apply load F in the opposite direction, as shown in the figure to the right.	 <p>xx0300000187</p> <p><b>Values for IRB 4600 - 60/2.05</b></p> <ul style="list-style-type: none"> <li>• A: Measuring tool, play</li> <li>• B: 207.5 mm</li> <li>• C: 135 mm</li> <li>• F: 90N</li> </ul>
7	Remove the load and measure the play by reading the dial indicator.	The maximum play allowed at the given distance from the center of axis 5 is, for robot version: <ul style="list-style-type: none"> <li>• IRB 4600 - 60/2.05</li> </ul>

## 4.4.5 Measuring the play, axis 6

### General

After reassembly due to repair work or any other reason, the play in axis 5 and 6 must be checked to ensure the repetition accuracy of the robot positioning. The procedure for axis 6 is detailed below.

### Required equipment

Equipment	Article number	Note
Standard toolkit	-	Content is defined in section <a href="#">Standard tools on page 398</a> .
Measuring tool, play (IRB 4600 -60/2.05)	3HAB1611-6	
Other tools and procedures may be required. See references to these procedures in the step-by-step instructions below.		These procedures include references to the tools required.

### Additional equipment - Foundry Prime

Equipment	Article number	Note
Rust preventive	3HAC034903-001	Mercasol
Sikaflex 521FC	3HAC026759-001	
Loctite 574	12340011-116	
Brush		
Foundry Prime touch up kit	3HAC035355-001	

### Measurement, axis 6

The procedure below details how to measure the play in axis 6.



#### Note

The measuring tool and measuring values differ depending on robot version.



	Action	Information
1	<b>DANGER</b> Turn off all: <ul style="list-style-type: none"> <li>• electric power supply</li> <li>• hydraulic pressure supply</li> </ul> to the robot, before entering the robot working area.	
2	Fit the <i>measuring tool, play</i> to the turning disc.	Article number is specified in <a href="#">Required equipment on page 291</a> .

*Continues on next page*

## 4 Repair

### 4.4.5 Measuring the play, axis 6

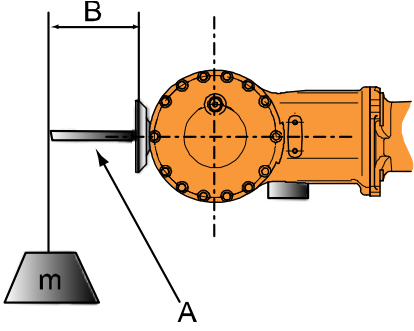
Continued

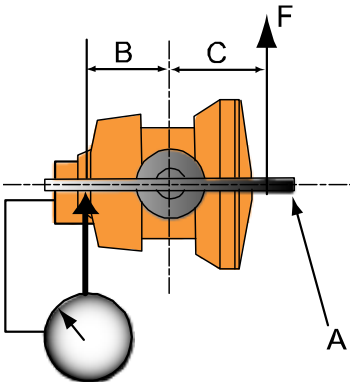
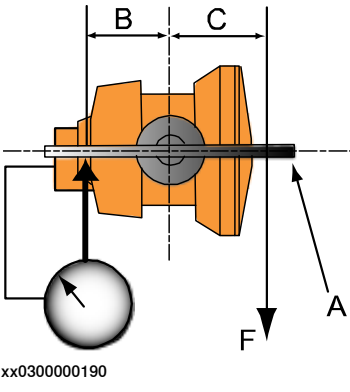
	Action	Information
3	<p>Attach a weight (m) at a distance (B) from the wrist flange, in order to avoid the effects of play on axis 5.</p> <p> <b>Note</b></p> <p>Different weight and distance for the different robot versions, as specified to the right.</p>	 <p>xx0300000188</p> <p><b>Values for robot versions IRB 4600 -60/2.05</b></p> <ul style="list-style-type: none"> <li>• A: Measuring tool, play</li> <li>• B: 207.5 mm</li> <li>• m: 20 kg</li> </ul>
4	<p>Apply load F in one direction.</p> <p> <b>Note</b></p> <p>Different load and distances for the different robot versions, as specified to the right.</p>	 <p>xx0300000189</p> <p><b>Values for robot versions IRB 4600 -60/2.05</b></p> <ul style="list-style-type: none"> <li>• A: Measuring tool, play</li> <li>• B: 100 mm</li> <li>• C: 100 mm</li> <li>• F: 50N</li> </ul>
5	<p>Remove the load and set the dial indicator to zero.</p>	
6	<p>Apply load F in the opposite direction, as shown in the figure to the right.</p>	 <p>xx0300000190</p> <p><b>Values for robot versions IRB 4600 -60/2.05</b></p> <ul style="list-style-type: none"> <li>• A: Measuring tool, play</li> <li>• B: 100 mm</li> <li>• C: 100 mm</li> <li>• F: 50N</li> </ul>

Continues on next page



	Action	Information
7	Remove the load and measure the play by reading the dial indicator.	The maximum play allowed at the given distance (B) from the center of axis 6 is, for robot version: <ul style="list-style-type: none"><li>• IRB 4600 -60/2.05</li></ul>

## 4 Repair

### 4.5.1 Replacing the lower arm

## 4.5 Lower arm

### 4.5.1 Replacing the lower arm

#### Location of lower arm

The lower arm is located as shown in the figure.

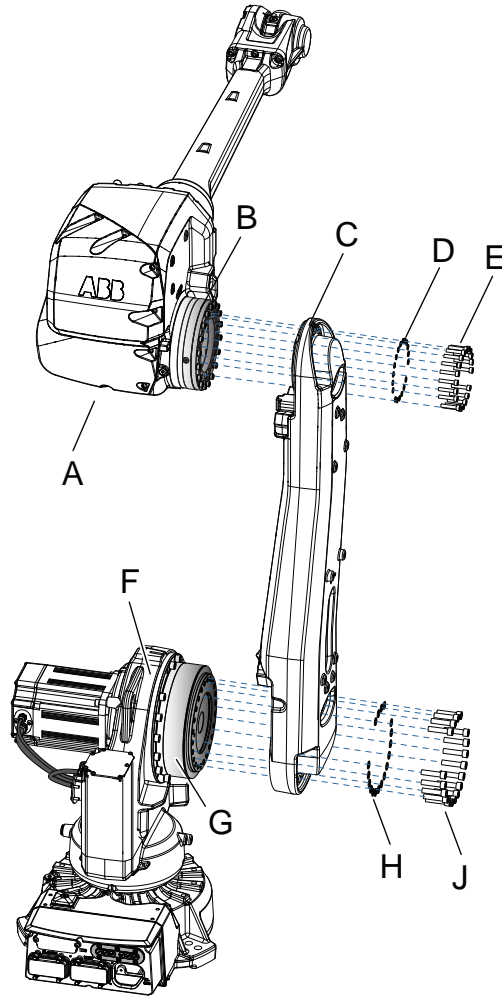

xx0800000360

A	Upper arm
B	Axis-3 gearbox
C	Lower arm
D	Washer (19 pcs)
E	Attachment screws M8x40 quality Steel 12.9 Gleitmo (19 pcs)
F	Frame
G	Axis-2 gearbox
H	Washer (18 pcs)
J	Attachment screws M12x50 quality Steel 12.9 Gleitmo (18 pcs)

*Continues on next page*

## Required equipment

Equipment	Note
Lower arm	For spare parts no. see Spare parts - Lower arm and motors in Product manual, spare parts - IRB 2600.
Lifting eye	M8
Standard toolkit	Content is defined in section <a href="#">Standard tools on page 398</a> .
Other tools and procedures may be required. See references to these procedures in the step-by-step instructions below.	These procedures include references to the tools required.

## Additional equipment - Foundry Prime

Equipment	Art. no.	Note
Rust preventive	3HAC034903-001	Mercasol
Sikaflex 521FC	3HAC026759-001	
Loctite 574	12340011-116	
Brush		
Foundry Prime touch up kit	3HAC035355-001	

## Deciding calibration routine

Decide which calibration routine to be used, based on the information in the table. Depending on which routine is chosen, action might be required prior to beginning the repair work of the robot, see the table.

	Action	Note
1	<p>Decide which calibration routine to use for calibrating the robot.</p> <ul style="list-style-type: none"> <li>Reference calibration. External cable packages (DressPack) and tools can stay fitted on the robot.</li> <li>Fine calibration. All external cable packages (DressPack) and tools must be removed from the robot.</li> </ul>	
	<p><b>If the robot is to be calibrated with reference calibration:</b></p> <p>Find previous reference values for the axis or create new reference values. These values are to be used after the repair procedure is completed, for calibration of the robot.</p> <p>If no previous reference values exist, and no new reference values can be created, then reference calibration is not possible.</p>	<p>Follow the instructions given in the reference calibration routine on the FlexPendant to create reference values.</p> <p>Creating new values requires possibility to move the robot.</p> <p>Read more about reference calibration for Axis Calibration in <a href="#">Reference calibration routine on page 368</a>.</p> <p>Read more about reference calibration for Pendulum Calibration in <a href="#">Operating manual - Calibration Pendulum</a>.</p>
	<p><b>If the robot is to be calibrated with fine calibration:</b></p> <p>Remove all external cable packages (DressPack) and tools from the robot.</p>	

Continues on next page



## 4 Repair

### 4.5.1 Replacing the lower arm

*Continued*

#### Removing the lower arm

Use this procedure to remove the lower arm.

	Action	Note
1	Decide which calibration routine to use, and take actions accordingly prior to beginning the repair procedure.	
2	Move the robot to the position shown in the figure.	 <p data-bbox="954 846 1062 864">xx0800000336</p>
3	 <p data-bbox="563 936 671 958"><b>DANGER</b></p> <p data-bbox="475 992 600 1014">Turn off all:</p> <ul data-bbox="507 1025 831 1088" style="list-style-type: none"> <li>• electric power supply</li> <li>• hydraulic pressure supply</li> </ul> <p data-bbox="475 1093 890 1144">to the robot, before entering the robot working area.</p>	
4	Remove the <i>cable package</i> from all axes except in the base.	<p data-bbox="954 1182 1378 1256">How to remove the cable package in frame, lower arm and armhouse is described in sections:</p> <ul data-bbox="986 1261 1401 1435" style="list-style-type: none"> <li>• <a href="#">Removing cable harness in frame on page 211</a></li> <li>• <a href="#">Removing cable harness in lower arm and armhouse on page 213</a></li> <li>• <a href="#">Replacement of air nipples and hoses (Foundry Prime) on page 232</a></li> </ul>
5	Secure the upper arm with a roundsling in an overhead crane.	
6	 <p data-bbox="563 1552 676 1574"><b>CAUTION</b></p> <p data-bbox="475 1615 938 1720">Always cut the paint with a knife and grind the paint edge when disassembling parts. See <a href="#">Cut the paint or surface on the robot before replacing parts on page 200</a>.</p>	
7	Remove the <i>complete upper arm</i> and put it on a loading pallet.	<p data-bbox="954 1758 1394 1809">How to remove the complete upper arm is described in section:</p> <ul data-bbox="986 1809 1406 1861" style="list-style-type: none"> <li>• <a href="#">Removing the complete upper arm on page 268</a></li> </ul>

*Continues on next page*

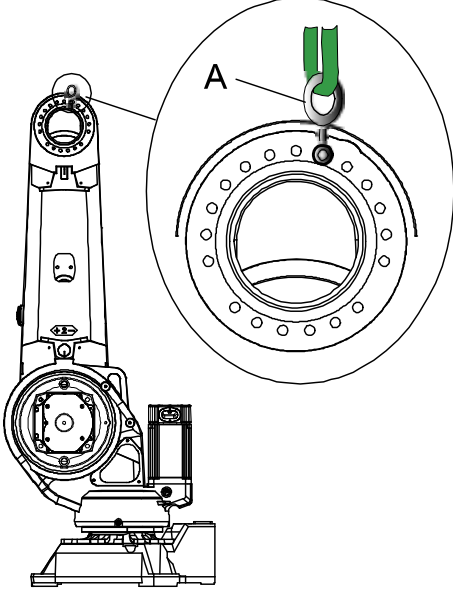
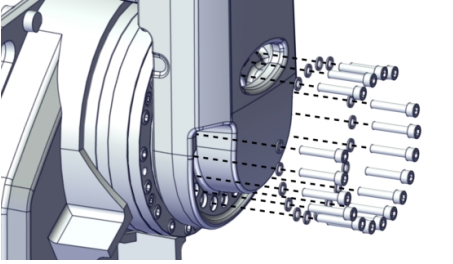
	Action	Note
8	<p> <b>CAUTION</b></p> <p>The robot lower arm weighs 65 kg. All lifting accessories used must be sized accordingly!</p>	
9	<p>Fit a <i>lifting lug</i> in one of the upper holes in the lower arm, for the attachment screws.</p>	 <p>xx0800000379</p> <p>Parts:</p> <ul style="list-style-type: none"> <li>• A: Lifting lug</li> </ul>
10	<p>Remove the <i>attachment screws and washers</i> that secure the lower arm to the axis-2 gearbox.</p>	 <p>xx1800000935</p>
11	<p>Remove the lower arm.</p>	

**Refitting the lower arm**

Use this procedure to refit the lower arm.

	Action	Note
1	<p> <b>DANGER</b></p> <p>Turn off all:</p> <ul style="list-style-type: none"> <li>• electric power supply</li> <li>• hydraulic pressure supply</li> </ul> <p>to the robot, before entering the robot working area.</p>	

Continues on next page

## 4 Repair

### 4.5.1 Replacing the lower arm

Continued

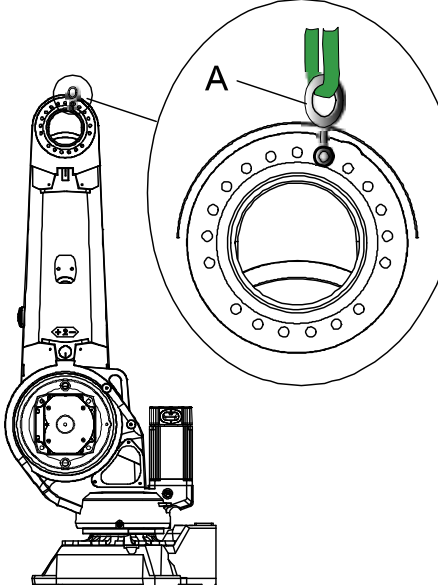
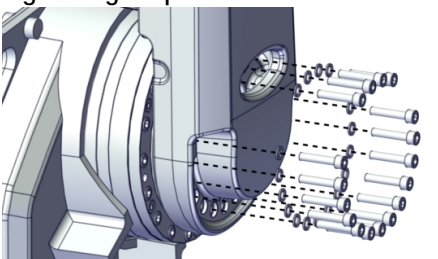
	Action	Note
2	Clean the joints that have been opened. See <a href="#">Cut the paint or surface on the robot before replacing parts on page 200</a>	
3	 <b>CAUTION</b> The robot lower arm weighs 65 kg. All lifting accessories used must be sized accordingly!	
4	Fit a <i>lifting lug</i> in one of the upper holes in the lower arm, for the attachment screws.	 <p>xx0800000379</p> <p>Parts:</p> <ul style="list-style-type: none"> <li>A: Lifting lug</li> </ul>
5	Secure the lower arm with a roundsling in an overhead crane and lift it to the robot.	
6	Refit the <i>attachment screws and washers</i> to secure the lower arm to the axis-2 gearbox.	<p>Attachment screws: M12x50 quality steel Gleitmo 12.9 (18 pcs)            Tightening torque: 110 Nm.</p>  <p>xx1800000935</p>
7	Secure the complete upper arm with roundslings in an overhead crane and lift it to the robot.	
8	Refit the <i>complete upper arm</i> .	<p>How to refit the complete upper arm is described in section:</p> <ul style="list-style-type: none"> <li><a href="#">Refitting the complete upper arm on page 273</a></li> </ul>

Continues on next page

	Action	Note
9	Refit the <i>cable package</i> .	<p>How to refit the cable package in frame, lower arm and armhouse is described in sections:</p> <ul style="list-style-type: none"> <li>• <a href="#">Refitting the cable harness in the frame on page 219</a></li> <li>• <a href="#">Refitting the cable harness in the lower arm and armhouse on page 229</a></li> <li>• <a href="#">Replacement of air nipples and hoses (Foundry Prime) on page 232</a></li> </ul>
10	Seal and paint the joints that have been opened. Also repair possible damages of the special Foundry Prime paint coat of the robot. See <a href="#">Cut the paint or surface on the robot before replacing parts on page 200</a> .	
11	Recalibrate the robot.	<p>Pendulum Calibration is described in <i>Operating manual - Calibration Pendulum</i>, enclosed with the calibration tools.</p> <p>Axis Calibration is described in <a href="#">Calibrating with Axis Calibration method on page 367</a>.</p> <p>General calibration information is included in section <a href="#">Calibration on page 353</a>.</p>
12	 <b>DANGER</b> Make sure all safety requirements are met when performing the first test run.	

## 4 Repair

### 4.6.1 Replacing stop pin axis 1

## 4.6 Frame and base

### 4.6.1 Replacing stop pin axis 1

#### Location of stop pin axis 1

The stop pin axis 1 is located as shown in the figure.

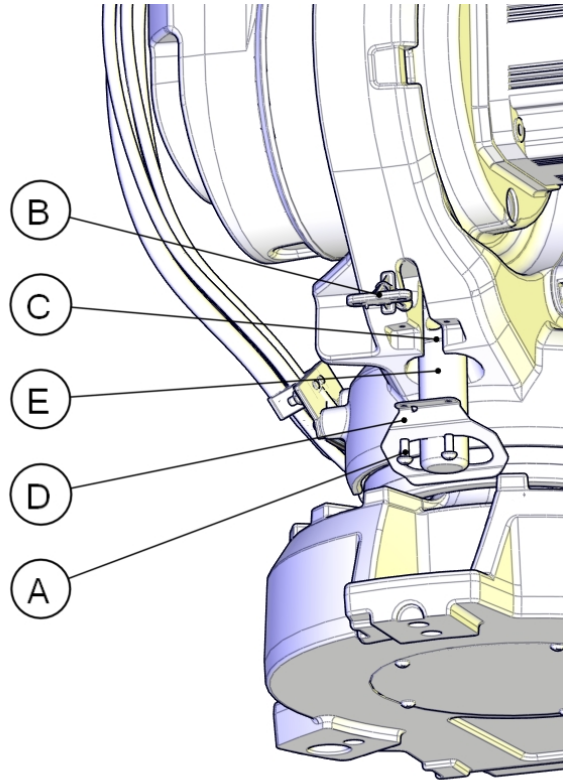

xx080000045

A	Attachment screws M6x16 quality 8.8-A2F (2 pcs)
B	Bracket
C	O-ring (2 pcs) - Not used if bracket (D) is installed.
D	Bracket
E	Stop pin

#### Required equipment

Equipment	Note
Stop pin	For spare parts number, see Spare parts - Frame and base in Product manual, spare parts - IRB 2600.
Standard toolkit	Content is defined in section <a href="#">Standard tools on page 398</a> .

Continues on next page





Equipment	Note
Other tools and procedures may be required. See references to these procedures in the step-by-step instructions below.	These procedures include references to the tools required.

#### Additional equipment - Foundry Prime

Equipment	Art. no.	Note
Rust preventive	3HAC034903-001	Mercasol
Sikaflex 521FC	3HAC026759-001	
Loctite 574	12340011-116	
Brush		
Foundry Prime touch up kit	3HAC035355-001	

#### Removing the stop pin, axis 1

Use this procedure to remove the stop pin axis 1.

	Action	Note
1	 <b>DANGER</b> Turn off all: <ul style="list-style-type: none"> <li>• electric power supply</li> <li>• hydraulic pressure supply</li> </ul> to the robot, before entering the robot working area.	
2	 <b>CAUTION</b> Always cut the paint with a knife and grind the paint edge when disassembling parts. See <a href="#">Cut the paint or surface on the robot before replacing parts on page 200</a> .	
3	Remove the <i>attachment screws</i> securing the <i>bracket</i> and <i>stop pin</i> .	See the figure in <ul style="list-style-type: none"> <li>• <a href="#">Location of stop pin axis 1 on page 300</a></li> </ul>
4	Remove the <i>bracket</i> and <i>stop pin</i> .	See the figure in <ul style="list-style-type: none"> <li>• <a href="#">Location of stop pin axis 1 on page 300</a></li> </ul>

Continues on next page



## 4 Repair

### 4.6.1 Replacing stop pin axis 1

Continued

#### Refitting the stop pin, axis 1

Use this procedure to refit the stop pin axis 1.

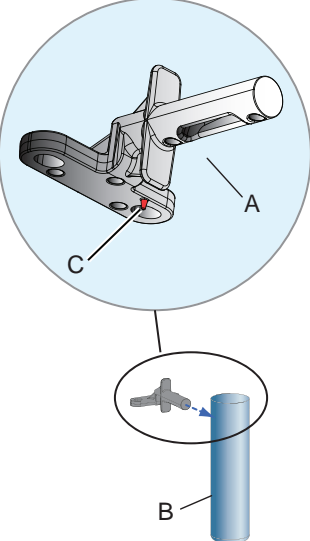
	Action	Note
1	 <p><b>DANGER</b></p> <p>Turn off all:</p> <ul style="list-style-type: none"> <li>• electric power supply</li> <li>• hydraulic pressure supply</li> </ul> <p>to the robot, before entering the robot working area.</p>	
2	<p>Clean the joints that have been opened. See <a href="#">Cut the paint or surface on the robot before replacing parts on page 200</a></p>	
3	<p>Fit the two <i>o-rings</i> on the stop pin.</p>  <p><b>Note</b></p> <p>The <i>o-rings</i> are not used when bracket (D) is installed.</p>	<p>See the figure in</p> <ul style="list-style-type: none"> <li>• <a href="#">Location of stop pin axis 1 on page 300</a></li> </ul>
4	<p>Fit the <i>stop pin</i> on the <i>bracket</i>.</p>  <p><b>Note</b></p> <p>The small spike on the bracket shall be pointing downwards for correct fitting of the stop pin.</p>	 <p>xx0800000453</p> <p><b>Parts:</b></p> <ul style="list-style-type: none"> <li>• A: Bracket</li> <li>• B: Stop pin</li> <li>• C: Small spike</li> </ul>
5	<p>Secure the stop pin together with bracket (D) on the frame with its <i>attachment screws</i>. Use Locking liquid</p>	<p>3HAB7116-1 (Loctite 243). Tightening torque: 10 Nm</p> <p>See the figure in</p> <ul style="list-style-type: none"> <li>• <a href="#">Location of stop pin axis 1 on page 300</a></li> </ul>
6	<p>Seal and paint the joints that have been opened. Also repair possible damages of the special Foundry Prime paint coat of the robot. See <a href="#">Cut the paint or surface on the robot before replacing parts on page 200</a>.</p>	

Continues on next page

	Action	Note
7	 <b>DANGER</b> Make sure all safety requirements are met when performing the first test run.	

## 4 Repair

### 4.7.1 Removing motors

## 4.7 Motors

### 4.7.1 Removing motors

#### Introduction

This procedure describes how to remove motors on all axes of the robot.

#### Location of axis-1 and axis-2 motors (Foundry Prime)

The figure shows axis-1 motor on IRB 4600 Foundry Prime.

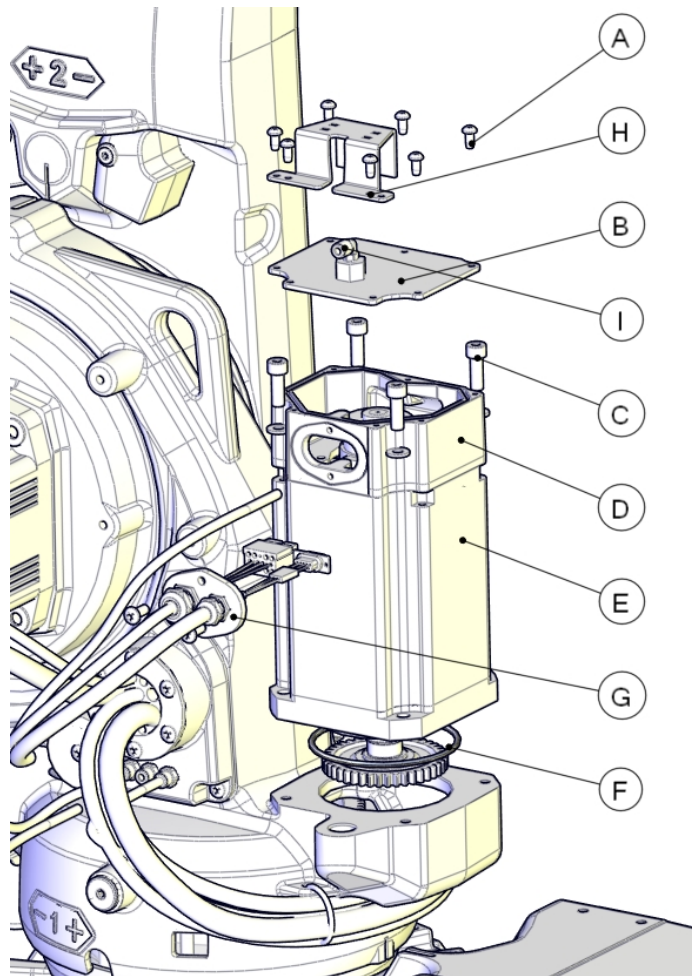

xx110000083

A	Attachment screws M5x16, quality Steel 8-A2F (7 pcs)
B	Motor cover
C	Attachment screws, motor axis 1 (4 pcs) + washers <i>Tightening torques and attachment screws on page 317.</i>
D	Connection box
E	Axis-1 motor
F	O-ring
G	Cable gland cover

*Continues on next page*

H	Hose protection
I	Elbow nipple

#### Location of axis-3, axis-4, axis-5 and axis-6 motors

The axis-3, axis-4, axis-5 and axis-6 motors are located as shown in the figures.

Motors: (3) = Axis-3 motor. (4) = Axis-4, axis-5 and axis-6 motors.

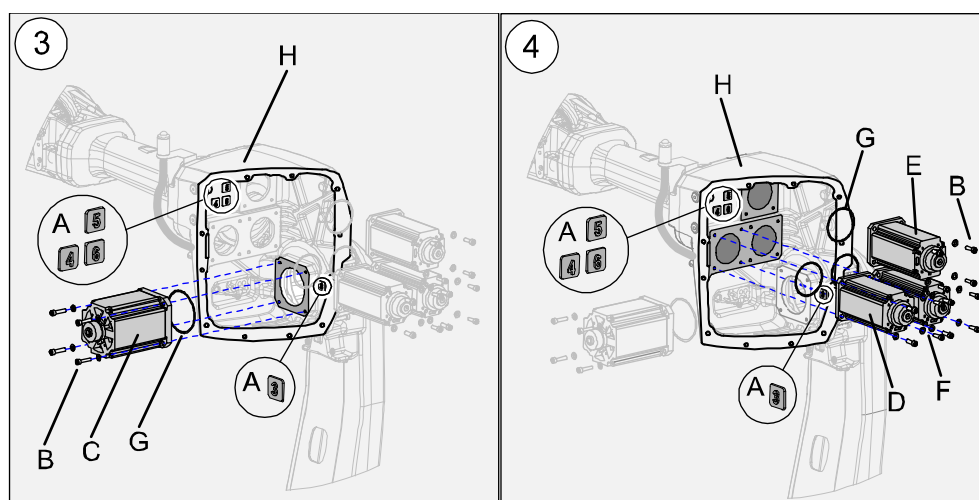

xx090000303

A	Markings inside armhouse, identifying the position of each motor
B	Attachment screws, axis-3 motor (4 pcs) + washers. See <a href="#">Tightening torques and attachment screws on page 317</a>
B	Attachment screws, axis-4, axis-5 and axis-6 motors (3x4 pcs) + washers. <a href="#">Tightening torques and attachment screws on page 317</a>
C	Axis-3 motor
D	Axis-4 motor
E	Axis-5 motor
F	Axis-6 motor
G	O-ring (axis-4, axis-5 and axis-6)
H	Armhouse

*Continues on next page*

## 4 Repair

### 4.7.1 Removing motors

Continued

#### Connectors, axis-3 and axis-4 motors

The figure shows the connectors of motors axes 3-6.

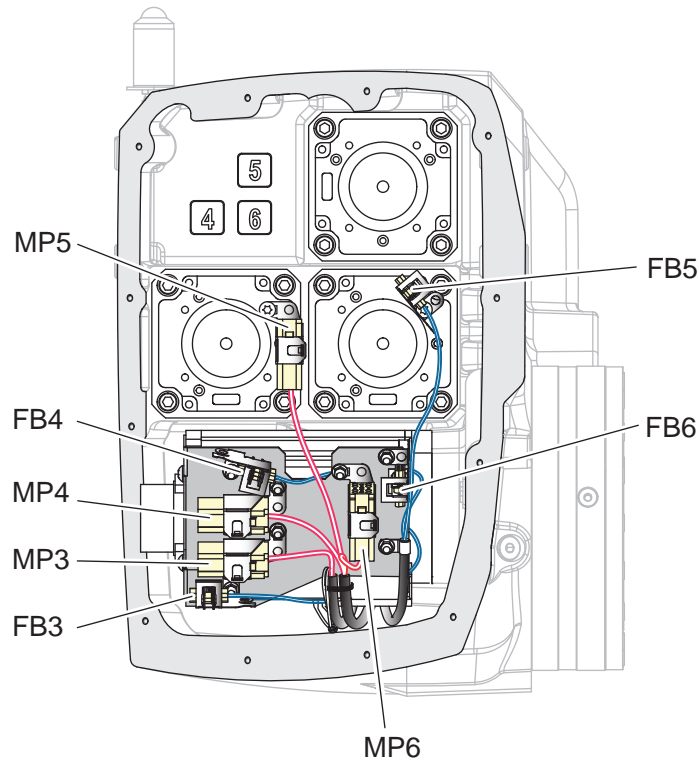

xx0900000410

#### Required equipment

Equipment	Note
Standard toolkit	Content is defined in section <a href="#">Standard tools on page 398</a> .
Other tools and procedures may be required. See references to these procedures in the step-by-step instructions below.	These procedures include references to the tools required.

#### Additional equipment - Foundry Prime

Equipment	Art. no.	Note
Rust preventive	3HAC034903-001	Mercasol
Sikaflex 521FC	3HAC026759-001	
Loctite 574	12340011-116	
Brush		
Foundry Prime touch up kit	3HAC035355-001	



#### CAUTION

Always cut the paint with a knife and grind the paint edge when disassembling parts. See [Cut the paint or surface on the robot before replacing parts on page 200](#).

Continues on next page

## Weights

The motors for the different axes weighs according to the table:

Motor	Weight in kg
Axis-1 motor	13 kg
Axis-2 motor	25 kg
Axis-3 motor	13 kg
Axis-4 motor	8 kg
Axis-5 motor	8 kg
Axis-6 motor	8 kg

**CAUTION**

All lifting equipment must be sized accordingly!

## Deciding calibration routine

Decide which calibration routine to be used, based on the information in the table. Depending on which routine is chosen, action might be required prior to beginning the repair work of the robot, see the table.

	Action	Note
1	Decide which calibration routine to use for calibrating the robot. <ul style="list-style-type: none"> <li>Reference calibration. External cable packages (DressPack) and tools can stay fitted on the robot.</li> <li>Fine calibration. All external cable packages (DressPack) and tools must be removed from the robot.</li> </ul>	
	<b>If the robot is to be calibrated with reference calibration:</b> Find previous reference values for the axis or create new reference values. These values are to be used after the repair procedure is completed, for calibration of the robot.  If no previous reference values exist, and no new reference values can be created, then reference calibration is not possible.	Follow the instructions given in the reference calibration routine on the FlexPendant to create reference values.  Creating new values requires possibility to move the robot.  Read more about reference calibration for Axis Calibration in <a href="#">Reference calibration routine on page 368</a> .  Read more about reference calibration for Pendulum Calibration in <i>Operating manual - Calibration Pendulum</i> .
	<b>If the robot is to be calibrated with fine calibration:</b> Remove all external cable packages (DressPack) and tools from the robot.	

Continues on next page

## 4 Repair

### 4.7.1 Removing motors

Continued

#### Position of robot

Use this procedure to place the robot in the position recommended in order to facilitate replacement of motors.

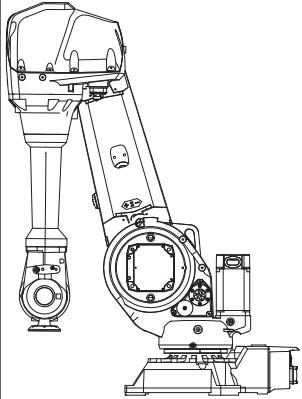
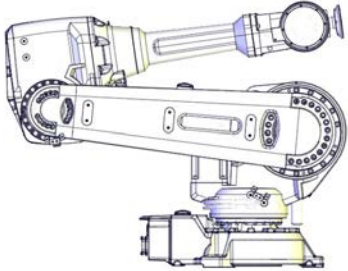
Action	Information
<p>Axis-1, axis-4, axis-5 and axis-6 motor</p> <ul style="list-style-type: none"> <li>Move the robot to a position where the wrist is pointing to the floor, as shown in the figure. This will make it possible to remove the motors without draining the oil from the gearbox.</li> </ul>	 <p>xx0800000388</p>
<p>Axis-2 motor</p> <ul style="list-style-type: none"> <li>Move the robot to a position where the lower arm rests firmly on the damper of axes 2 and 3. Release the brake of axis 2 to be sure that the lower arm rests in the end position.</li> </ul>	 <p>xx1100000548</p>
<p>Axis-3 motor</p> <ul style="list-style-type: none"> <li>Move axis-2 to 0° and axis-3 to maximal +. Release the brake of axis-3 to be sure that the upper arm is completely vertical and rests against the damper of axis-2 and axis-3.</li> </ul>	

#### Draining gearbox

Use this procedure to drain gearboxes, if needed.



#### Note

Draining of gearbox is only needed when removing the axes 2 and 3 motors.

Action	Note
<p>1 Axis-1 motor:</p> <ul style="list-style-type: none"> <li>Draining of gearbox is not needed.</li> </ul>	-
<p>2 Axis-2 motor:</p> <ul style="list-style-type: none"> <li>The gearbox has to be drained before removing the motor.</li> </ul>	<p>How to drain the gearbox is described in section:</p> <ul style="list-style-type: none"> <li><a href="#">Changing the oil, axis-2 gearbox on page 165</a></li> </ul>

Continues on next page



	Action	Note
3	Axis-3 motor: <ul style="list-style-type: none"> <li>The gearbox has to be drained before removing the motor.</li> </ul>	How to drain the gearbox is described in section: <ul style="list-style-type: none"> <li><a href="#">Changing the oil, axis-3 gearbox on page 169</a></li> </ul>
4	Axis-4, axis-5 and axis-6 motors: <ul style="list-style-type: none"> <li>Draining of gearbox oil is not needed if robot is positioned as recommended.</li> </ul>	-



### Removing motors

Use this procedure to remove the axis-1, axis-2, axis-3, axis-4, axis-5 and axis-6 motors.



#### Note

The procedure contains information how to remove motors on all axes of the robot. Some steps are only applicable to a certain motor. Follow the steps carefully in order not to miss vital information!



	Action	Note
1	Decide which calibration routine to use, and take actions accordingly prior to beginning the repair procedure.	
2	Move the robot to the recommended position for the motor that shall be removed.	Also see <ul style="list-style-type: none"> <li><a href="#">Position of robot on page 308</a></li> </ul>
3	 <b>DANGER</b> Turn off all: <ul style="list-style-type: none"> <li>electric power supply</li> <li>hydraulic pressure supply</li> </ul> to the robot, before entering the robot working area.	
4	Check if the gearbox needs to be drained.	Also see <ul style="list-style-type: none"> <li><a href="#">Draining gearbox on page 308</a></li> </ul>
5	 <b>CAUTION</b> Always cut the paint with a knife and grind the paint edge when disassembling parts. See <a href="#">Cut the paint or surface on the robot before replacing parts on page 200</a> .	

Continues on next page



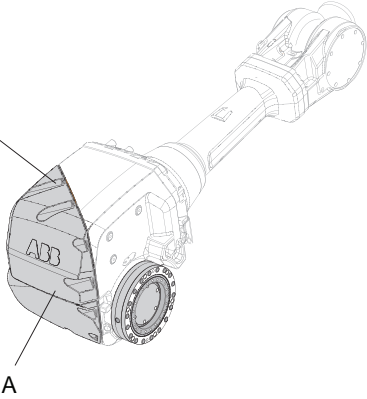

## 4 Repair

### 4.7.1 Removing motors

Continued

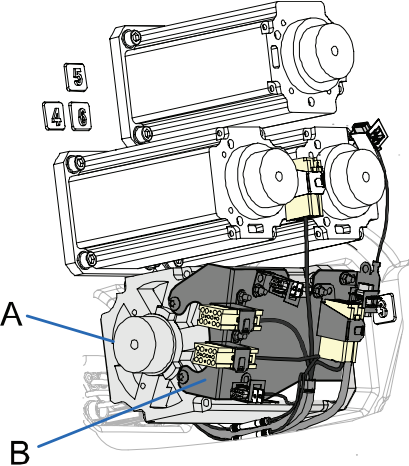
	Action	Note
6	<p><b>Only applicable to axis-3, axis-4, axis-5 and axis-6 motors!</b> Remove the cover in the back of the arm house.</p> <p> <b>WARNING</b></p> <p>The robot must never be run without the cover in the armhouse fitted! It is a vital supporting part of the robot.</p>	 <p>xx0800000389</p> <p><b>Parts:</b></p> <ul style="list-style-type: none"> <li>• A: Cover</li> <li>• B: Attachment screws (10 pcs) + washers.</li> </ul>
7	<p><b>Only applicable to axis-1 and axis-2 motors!</b> Remove the motor cover.</p>	<p>See the figure in:</p> <ul style="list-style-type: none"> <li>• <a href="#">Location of axis-1 and axis-2 motors (Foundry Prime) on page 304</a></li> </ul>
8	<p><b>Only applicable to axis-1 and axis-2 motors!</b> Remove the cable gland cover.</p>	<p>See the figure in:</p> <ul style="list-style-type: none"> <li>• <a href="#">Location of axis-1 and axis-2 motors (Foundry Prime) on page 304</a></li> </ul>
9	<p><b>Only applicable to axis-1 and axis-2 motors!</b> Remove the connection box.</p> <p> <b>Note</b></p> <p>Only needed if the motor shall be replaced with a new one.</p>	<p>See the figure in:</p> <ul style="list-style-type: none"> <li>• <a href="#">Location of axis-1 and axis-2 motors (Foundry Prime) on page 304</a></li> </ul>
10	<p>Disconnect the <i>motor cables</i>.</p>	<p> <b>Note</b></p> <p>When removing the axis-3 motor, the cables of the axis-4, axis-5 and axis-6 motors must be disconnected too. This must be done in order to be able to remove the bracket on top of the axis-3 motor.</p>

Continues on next page

	Action	Note
11	<p><b>Only applicable to axis-3 motor!</b> Remove the <i>bracket</i> from the axis-3 motor.</p>	 <p>xx080000390</p> <p>Parts:</p> <ul style="list-style-type: none"> <li>• A: Axis-3 motor</li> <li>• B: Bracket</li> </ul>
12	<p>In order to release the brakes of the motor to be removed, connect the 24 VDC power supply to the motor connector.</p> <p> <b>Tip</b></p> <p>For axis-2 and axis-3 motors: release the motor brake until the arm firmly rests on the damper for each axis respectively. See positions in <a href="#">Position of robot on page 308</a>.</p>	<p>Connectors:</p> <ul style="list-style-type: none"> <li>• Axis-1 motor: R2.MP1</li> <li>• Axis-2 motor: R2.MP2</li> <li>• Axis-3 motor: R2.MP3</li> <li>• Axis-4 motor: R2.MP4</li> <li>• Axis-5 motor: R2.MP5</li> <li>• Axis-6 motor: R2.MP6</li> </ul> <p>Connect to pins:</p> <ul style="list-style-type: none"> <li>• + : pin 2</li> <li>• -: pin 5</li> </ul> <p> <b>CAUTION</b></p> <p>The connections for the motor brakes (24 VDC connection) are phase dependent. If the connection on the pins is switched, it can cause severe damage to vital parts.</p>
13	<p> <b>Note</b></p> <p>Whenever parting/mating motor and gearbox, the gears may be damaged if excessive force is used!</p>	
14	<p>Remove the attachment screws securing the motor.</p> <p>If needed use a 300 mm extension for bits 1/2" (Motor axis 1).</p>	<p>See the figure in:</p> <ul style="list-style-type: none"> <li>• <a href="#">Location of axis-1 and axis-2 motors (Foundry Prime) on page 304</a></li> </ul>
15	<p>If required, press the motor out of position by fitting two screws in the threaded holes in the motor flange.</p>	<p> <b>Note</b></p> <p>Always use removal tools in pairs diagonal to each other.</p>

Continues on next page

## 4 Repair

### 4.7.1 Removing motors

*Continued*

	Action	Note
16	Remove the motor!	 <b>CAUTION</b> Lift the motor gently in order not to damage pinion or gears.
17	<b>Only applicable to motor axis 1!</b> Cover the hole if replacement of motor axis 1 is not immediate, in order to avoid contamination.	See the figure in: <ul style="list-style-type: none"><li>• <a href="#">Location of axis-1 and axis-2 motors (Foundry Prime) on page 304</a></li></ul>
18	<b>Only applicable to motors axes 4, 5 and 6!</b> Check that the o-ring also is removed. It might stay in the armhouse when the motor is removed.	See the figure in: <ul style="list-style-type: none"><li>• <a href="#">Location of axis-1 and axis-2 motors (Foundry Prime) on page 304</a></li></ul>

## 4.7.2 Refitting motors

### Introduction

This procedure describes how to refit motors on all axes of the robot.



#### WARNING

When a motor is replaced, make sure to use the correct type of new motor. Motors of different types may not be compatible. See the *Spare parts manual* on myABB business portal ([www.abb.com/myABB](http://www.abb.com/myABB)).

### Location of axis-1 and axis-2 motors, (Foundry Prime)

The figure shows motor axis1 on IRB 4600 Foundry Prime.

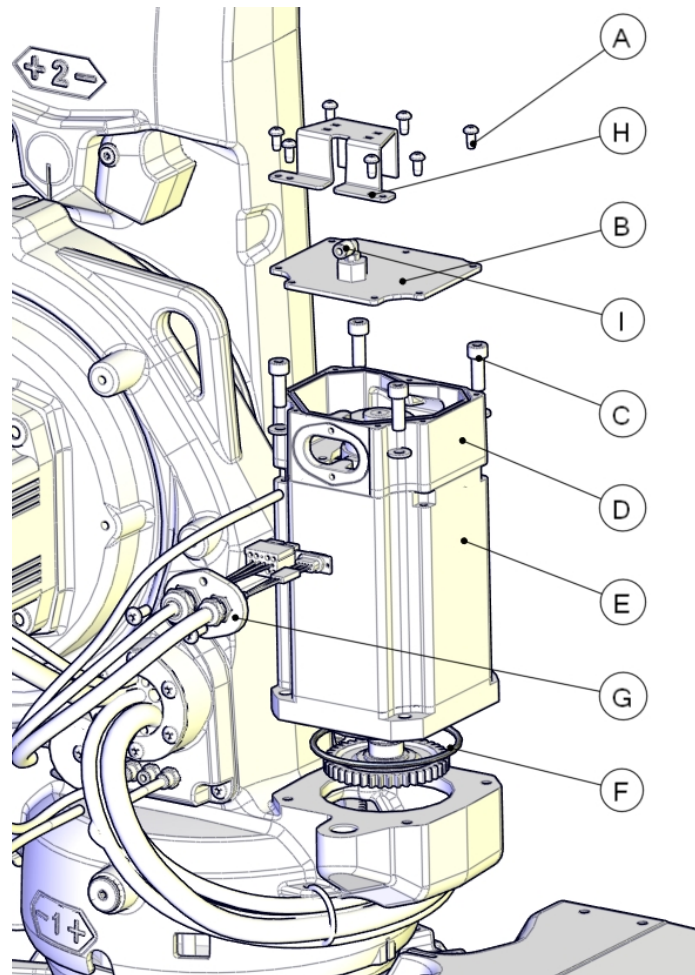

xx110000083

A	Attachment screws M5x16, quality Steel 8-A2F (7 pcs)
B	Motor cover
C	Attachment screws, motor axis 1 (4 pcs) + washers <i>Tightening torques and attachment screws on page 317.</i>
D	Connection box

*Continues on next page*

## 4 Repair

### 4.7.2 Refitting motors

Continued

E	Motor, axis 1
F	O-ring
G	Cable gland cover
H	Hose protection
I	Elbow nipple

#### Location of axis-3, axis-4, axis-5 and axis-6 motors

The axis-3, axis-4, axis-5 and axis-6 motors are located as shown in the figures.

Motors:

(3) = Axis-3 motor

(4) = Axis-4, axis-5 and axis-6 motors

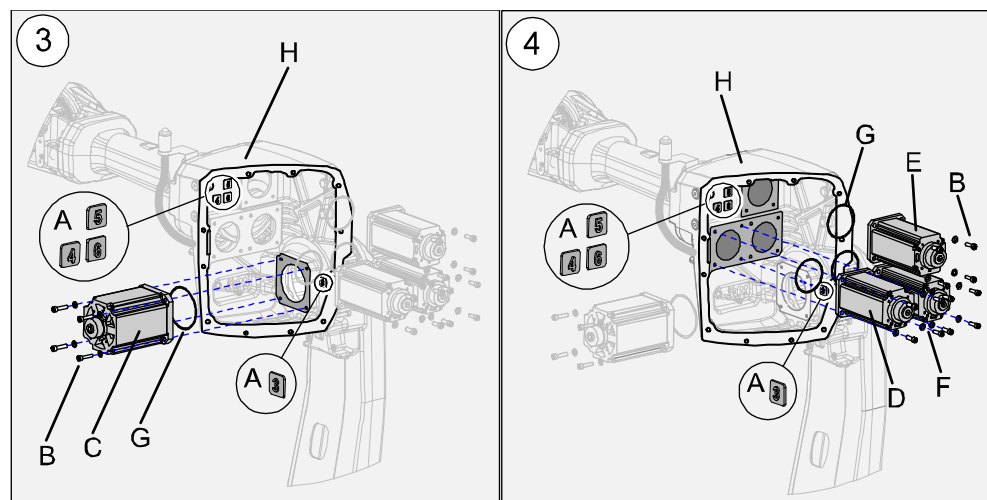

xx0900000303

A	Markings inside armhouse, identifying the position of each motor
B	Attachment screws, axis-3 motor, (4 pcs) + washers. See <a href="#">Tightening torques and attachment screws on page 317</a>
B	Attachment screws, axis-4, axis-5 and axis-6 motors, (3x4 pcs) + washers. See <a href="#">Tightening torques and attachment screws on page 317</a>
C	Axis-3 motor
D	Axis-4 motor
E	Axis-5 motor
F	Axis-6 motor
G	O-ring (axis-4, axis-5 and axis-6)
H	Armhouse

Continues on next page

**Connectors, axis-3 and axis-4 motors**

The figure shows the connectors of the axis-3 and axis-4 motors.

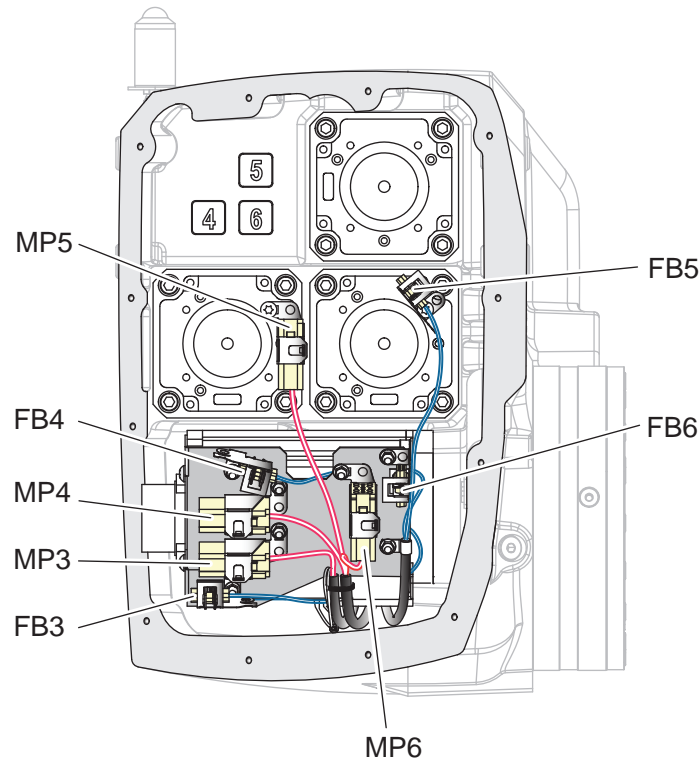

xx0900000410

**Required equipment**

Equipment	Note
Standard toolkit	Content is defined in section <a href="#">Standard tools on page 398</a> .
Other tools and procedures may be required. See references to these procedures in the step-by-step instructions below.	These procedures include references to the tools required.
Lifting tool, axis-2	For art. no. see <i>Reference information</i> .
Lifting tool, axis-3	For art. no. see <i>Reference information</i> .
Motors	For spare part no. see <a href="#">Spare part lists on page 403</a> .

**Additional equipment - Foundry Prime**

Equipment	Art. no.	Note
Rust preventive	3HAC034903-001	Mercasol
Sikaflex 521FC	3HAC026759-001	
Loctite 574	12340011-116	
Brush		
Foundry Prime touch up kit	3HAC035355-001	

*Continues on next page*

## 4 Repair

### 4.7.2 Refitting motors

Continued



#### CAUTION

Always cut the paint with a knife and grind the paint edge when disassembling parts. See [Cut the paint or surface on the robot before replacing parts on page 200](#).

### Weights

The motors for the different axes weighs according to the table:

Motor	Weight in kg
Axis-1 motor	13 kg
Axis-2 motor	25 kg
Axis-3 motor	13 kg
Axis-4 motor	8 kg
Axis-5 motor	8 kg
Axis-6 motor	8 kg



#### CAUTION

All lifting equipment must be sized accordingly!

### Position of robot

Use this procedure to place the robot in the position recommended in order to facilitate replacement of motors.

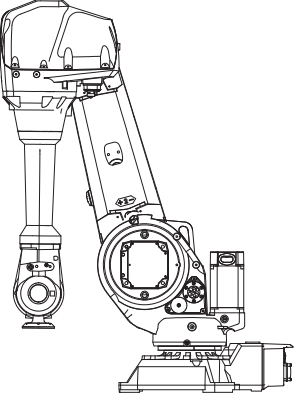
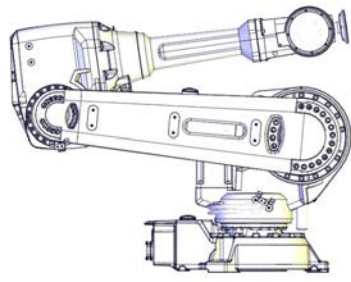
Action	Information
<p>Axis-1, axis-4, axis-5 and axis-6 motors</p> <ul style="list-style-type: none"><li>Move the robot to a position where the wrist is pointing to the floor, as shown in the figure. This will make it possible to remove the motors without draining the oil from the gearbox.</li></ul>	 <p>xx0800000388</p>
<p>Axis-2 motor</p> <ul style="list-style-type: none"><li>Move the robot to a position where the lower arm rests firmly on the axis-3 damper. Release the axis-2 brake to be sure that the lower arm rests in the end position.</li></ul>	 <p>xx1100000548</p>

Continues on next page



Action	Information
Axis-3 motor <ul style="list-style-type: none"> <li>Move axis-2 to 0° and axis-3 to maximal +. Release the axis-3 brake to be sure that the upper arm is completely vertical and rests against the damper.</li> </ul>	

### Filling oil in gearbox

Use this procedure to fill oil in gearbox, if needed.



#### Note

Filling oil in the gearbox is only needed when refitting motors axes 2 and 3.

	Action	Note
1	Axis-1 motor: <ul style="list-style-type: none"> <li>Filling gearbox oil not needed.</li> </ul>	-
2	Axis-2 motor: <ul style="list-style-type: none"> <li>Refill oil in gearbox after refitting.</li> </ul>	How to fill oil in gearbox is described in section: <ul style="list-style-type: none"> <li><a href="#">Changing the oil, axis-2 gearbox on page 165</a></li> </ul>
3	Axis-3 motor: <ul style="list-style-type: none"> <li>Refill oil in gearbox after refitting.</li> </ul>	How to fill oil in gearbox is described in section: <ul style="list-style-type: none"> <li><a href="#">Changing the oil, axis-3 gearbox on page 169</a></li> </ul>
4	Axis-4, axis-5 and axis-6 motors: <ul style="list-style-type: none"> <li>Filling gearbox oil not needed.</li> </ul>	-

### Tightening torques and attachment screws

The table shows the tightening torques for all motors.

Motor	Attachment screw	Quality	Tightening torque
Motor, axis 1	M8x25	8.8-A2F	22 Nm
Motor, axis 2	<a href="#">Screwlengths depending on flange thickness on page 317</a>	8.8-A2F	35 Nm
Motor, axis 3	<a href="#">Screwlengths depending on flange thickness on page 317</a>	8.8-A2F	22 Nm
Motor, axis 4	M8x25	8.8-A2F	22 Nm
Motor, axis 5	M8x25	8.8-A2F	22 Nm
Motor, axis 6	M8x25	8.8-A2F	22 Nm

### Screwlengths depending on flange thickness

Screwlengths can vary depending on when the robot is delivered. The different screwlengths depends on the different flange thickness of motors. Make sure to use the correct screwlength! See table:

Motor axis 2		Motor axis 3	
Flange thickness	Attachment screws	Flange thickness	Attachment screws
18.5 mm	M10x40	15 mm	M8x35

Continues on next page

## 4 Repair

### 4.7.2 Refitting motors

Continued

Motor axis 2		Motor axis 3	
16 mm	M10x35	13 mm	M8x30

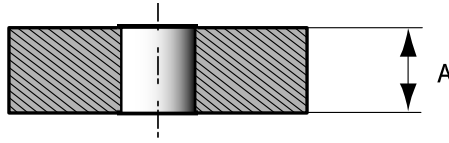

xx0900000443

A	Flange thickness
---	------------------

### Preparations before the refitting of motors

Use this procedure to make necessary preparations before refitting motors.

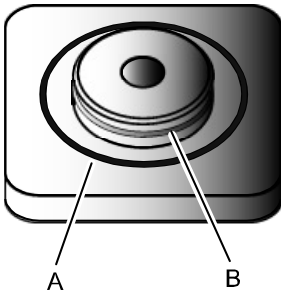
Action	Note
<p>1</p>  <p><b>DANGER</b></p> <p>Turn off all:</p> <ul style="list-style-type: none"> <li>• electric power supply</li> <li>• hydraulic pressure supply</li> </ul> <p>to the robot, before entering the robot working area.</p>	
2	Grind the paint on the surface carefully to get a smooth surface.
3	Clean the surface from contamination such as oil and dirt. Remove any painting from the assembly surfaces, with a knife.
4	Make sure that the motor and the pinion are not damaged or scratched.
5	Apply <i>Loctite 574</i> on the o-ring.
6	<p>Make sure the <i>o-ring</i> on the flange of the motor is seated properly.</p>  <p>xx0900000082</p> <p>Parts:</p> <ul style="list-style-type: none"> <li>• A: Correct position of o-ring</li> <li>• B: Incorrect position of o-ring !</li> </ul> <p>Replace with a new o-ring if damaged!</p>

Continues on next page

	Action	Note
7	In order to release the brakes, connect the 24 VDC power supply.	<p>Connectors:</p> <ul style="list-style-type: none"> <li>• Motor axis 1: R2.MP1</li> <li>• Motor axis 2: R2.MP2</li> <li>• Motor axis 3: R2.MP3</li> <li>• Motor axis 4: R2.MP4</li> <li>• Motor axis 5: R2.MP5</li> <li>• Motor axis 6: R2.MP6</li> </ul> <p>Connect to pins:</p> <ul style="list-style-type: none"> <li>• + : pin 2</li> <li>• -: pin 5</li> </ul> <p> <b>CAUTION</b></p> <p>The connections for the motor brakes (24 VDC connection) are phase dependent. If the connection on the pins is switched, it can cause severe damage to vital parts.</p>

### Refitting motors

Use this procedure to refit motors axes 1, 2, 3, 4, 5 and 6.



#### Note

The procedure contains information how to refit motors on all axes of the robot. Some steps are only applicable to a certain motor. Follow the steps carefully in order not to miss vital information!

	Action	Information
1	<b>Note</b> Before starting the refitting of the motor, first make the necessary preparations!	Also see <ul style="list-style-type: none"> <li>• <a href="#">Preparations before the refitting of motors on page 318</a></li> </ul>
2	<b>Note</b> Whenever parting/mating motor and gearbox, the gears may be damaged if excessive force is used!	
3	Clean the joints that have been opened. See <a href="#">Cut the paint or surface on the robot before replacing parts on page 200</a>	

*Continues on next page*



## 4 Repair

### 4.7.2 Refitting motors

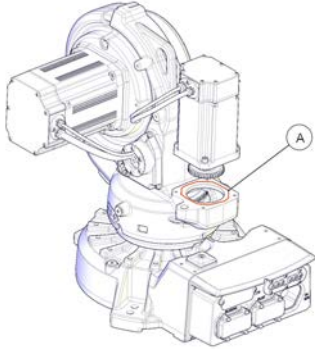
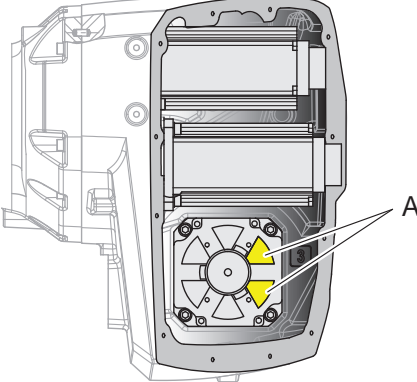
Continued

	Action	Information
4	Apply Loctite 574 on the surface as shown (A) in the figure.	 <p>xx110000549</p>
5	Place the motor carefully in the gearbox.	
6	Fit the motor, making sure the motor pinion is properly mated to the gear in the gearbox.	<b>Make sure that:</b> <ul style="list-style-type: none"><li>• the motor is turned the correct way</li><li>• the pinion or gear of the motor does not get damaged!</li></ul>
7	<b>Applicable to motor axis 3!</b> Make sure that the wire exit holes of motor axis 3 are in the correct position. See illustration!	 <p>xx090000300</p> <p><b>Parts:</b></p> <ul style="list-style-type: none"><li>• A: Wire exit holes, motor axis 3</li></ul>

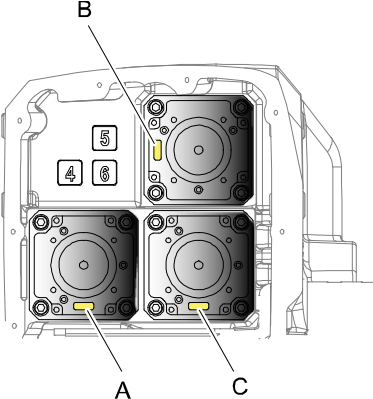
Continues on next page



	Action	Information
8	<b>Applicable to motors axes 4, 5 and 6!</b> Make sure that the wire exit hole of the motor is in the correct position.	 <p>xx0900000062</p> <p><b>Parts:</b></p> <ul style="list-style-type: none"> <li>• A: Wire exit hole, motor axis 4</li> <li>• B: Wire exit hole, motor axis 5</li> <li>• C: Wire exit hole, motor axis 6</li> </ul>
9	<b>Only applicable to motors axes 4, 5 and 6!</b> Fit the attachment screws for the motor and fasten them slightly. The motor must be able to move parallel to the gear during the adjustment of the play.	
10	<b>Only applicable to motors axes 4, 5 and 6!</b> Adjust the play of the motor.	See <a href="#">Adjusting the play of axis 4, 5 and 6 motors on page 324</a> .
11	Secure the motor with its attachment screws and washers.  <b>Note</b> Apply the correct tightening torque!	Tightening torque and attachment screws are specified in the table: <ul style="list-style-type: none"> <li>• <a href="#">Tightening torques and attachment screws on page 317</a></li> </ul>
12	Disconnect the brake release voltage.	
13	<b>Only applicable to motors axes 1 and 2!</b> Refit the connection box (if it has been removed).  <b>Note</b> Make sure that the o-ring is in place!	See the figure in: <ul style="list-style-type: none"> <li>• <a href="#">Location of axis-1 and axis-2 motors, (Foundry Prime) on page 313</a></li> </ul>

Continues on next page

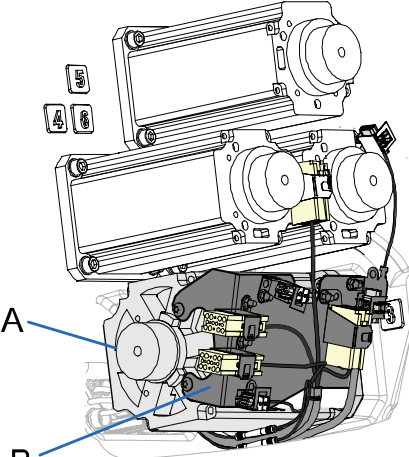

## 4 Repair

### 4.7.2 Refitting motors

Continued

	Action	Information
14	<p><b>Applicable to motor axis 3!</b> Refit the bracket on motor axis 3.</p>	 <p>xx0800000390</p> <p>Parts:</p> <ul style="list-style-type: none"> <li>• A: Motor axis 3</li> <li>• B: Bracket</li> </ul>
15	Reconnect the motor cables.	
16	<p><b>Applicable to motor axes 1 and 2!</b> Refit the <i>cable gland</i> and motor covers. Make sure that the <i>o-ring</i> is in place!</p>	<p>See the figure in:</p> <ul style="list-style-type: none"> <li>• <a href="#">Location of axis-1 and axis-2 motors, (Foundry Prime) on page 313</a></li> </ul> <p> <b>Note</b></p> <p>Make sure that the cover is tightly sealed!</p>
17	<p><b>Applicable to motors axis 2!</b> Refill gearbox oil.</p>	<p>How to fill oil in the gearbox is described in sections:</p> <ul style="list-style-type: none"> <li>• <a href="#">Changing the oil, axis-2 gearbox on page 165</a></li> <li>• <a href="#">Changing the oil, axis-3 gearbox on page 169</a></li> </ul>
18	<p><b>Applicable to motors axes 3, 4, 5 and 6!</b> Make sure that the gasket on the cover on the armhouse is intact.</p>	<p>If the gasket is damaged, it need to be replaced.</p>

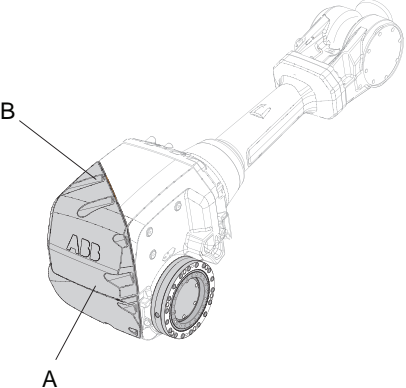
Continues on next page

	Action	Information
19	<p><b>Applicable to motors axes 3, 4, 5 and 6!</b> Refit the cover in the back of the armhouse with its attachment screws and washers.</p> <p> <b>WARNING</b></p> <p>The cover on the armhouse must be fitted when the robot is running. It is a vital part for the stability of the robot.</p>	<p>Make sure that the cover is tightly sealed.</p>  <p>xx0800000389</p> <p><b>Parts:</b></p> <ul style="list-style-type: none"> <li>• A: Cover</li> <li>• B: Attachment screws M6x25, quality 8.8-A2F (10 pcs)</li> </ul> <p><b>Tightening torque:</b></p> <ul style="list-style-type: none"> <li>• 14 Nm</li> </ul>
20	<p>Make sure that the armhouse cover is tightly fitted. If there is a gap between the cover and the robot, seal with Sikaflex 521 FC.</p>	
21	<p>Seal and paint the joints that have been opened. Also repair possible damages of the special Foundry Prime paint coat of the robot. See <a href="#">Cut the paint or surface on the robot before replacing parts on page 200</a>.</p>	
22	<p>Recalibrate the robot.</p>	<p>Pendulum Calibration is described in <i>Operating manual - Calibration Pendulum</i>, enclosed with the calibration tools.</p> <p>Axis Calibration is described in <a href="#">Calibrating with Axis Calibration method on page 367</a>.</p> <p>General calibration information is included in section <a href="#">Calibration on page 353</a>.</p>
23	<p> <b>DANGER</b></p> <p>Make sure all safety requirements are met when performing the first test run.</p>	

## 4 Repair

### 4.7.3 Adjusting the play of axis 4, 5 and 6 motors

### 4.7.3 Adjusting the play of axis 4, 5 and 6 motors

#### Required equipment

Equipment	Note
Measuring tool	For adjusting the play.
Standard toolkit	Content is defined in section <a href="#">Standard tools on page 398</a> .
Other tools and procedures may be required. See references to these procedures in the step-by-step instructions below.	These procedures include references to the tools required.

#### Adjusting the play of axis 4, 5 and 6 motors

	Action	Note
1	Fit the measuring tool at the rear of the motor.	
2	<p>Adjust the play on the motor by starting with a big play and then gradually finding the smallest play. Use swift movements in order to avoid noticing the magnetic field which causes the gears to stick together. Follow the instructions for current motor:</p> <p><b>Motor axis 4:</b></p> <ol style="list-style-type: none"><li>1 Turn the motor shaft six turns and find the smallest play within this range.</li></ol> <p><b>Axis 5 motor:</b></p> <ol style="list-style-type: none"><li>1 Turn the outgoing shaft for axis 4 in intervals of 90° for one full turn and find the smallest play for the axis 5 motor within this range.</li><li>2 Turn the axis 5 motor one full turn at a time for a total of five turns and find the smallest play within this range.</li></ol> <p><b>Axis 6 motor:</b></p> <ol style="list-style-type: none"><li>1 Turn the outgoing shaft for axis 4 in intervals of 90° for one full turn and find the smallest play for the axis 6 motor within this area.</li><li>2 Turn the axis 5 motor one full turn at a time for a total of five turns and find the smallest play for axis 6 within this range.</li><li>3 Turn the axis 6 motor one full turn at a time for a total of three turns and find the smallest play for axis 6 within this range.</li></ol>	
3	Push or tap the motor in radial direction so that the play becomes minimal within one motor turn, without the gear "chewing".	



## 4.8 Gearboxes

### 4.8.1 Replacing gearbox axis 1

#### Location of gearbox

The gearbox is located as shown in the figure. The exploded view only shows the principle of the assembly. The actual replacing is recommended to be done with the robot resting on its side.

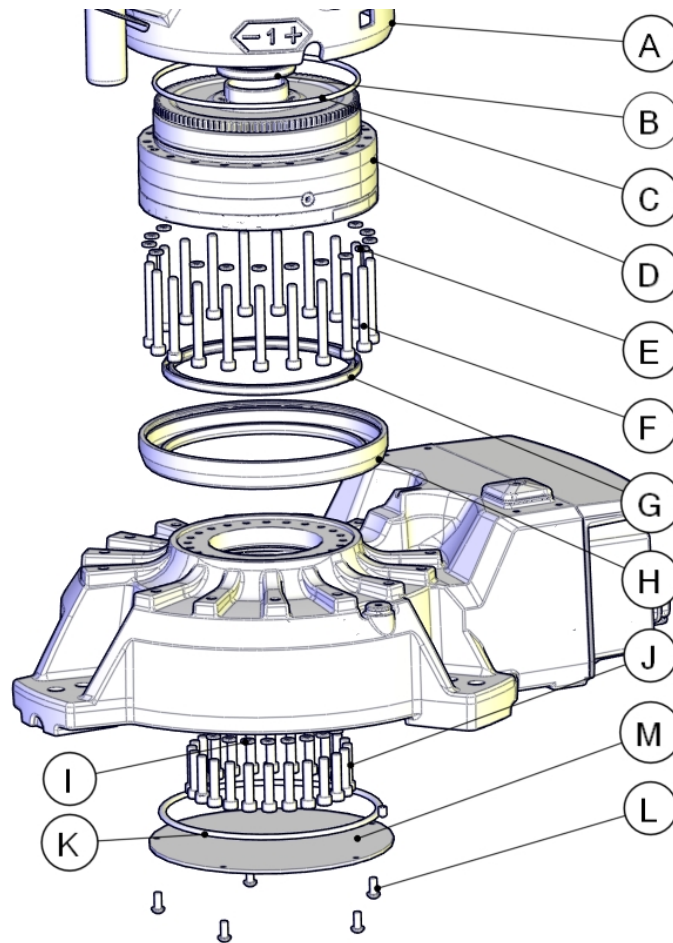

xx110000007

A	Frame
B	Radial sealing
C	O-ring
D	Gearbox axis 1
E	Washer (21 pcs)
F	Attachment screws M8x80 quality Steel 12.9 Gleitmo (21 pcs)
G	Radial sealing
H	Sealing ring

*Continues on next page*

## 4 Repair

### 4.8.1 Replacing gearbox axis 1

*Continued*

I	Washer
J	Attachment screws
K	O-ring
L	Attachment screws
M	Cover

#### Required equipment

Equipment	Note
Gearbox	See <a href="#">Spare part lists on page 403</a> .
Guide pins	Guide pin, M8x150: 3HAC15520-2 Used to guide the gearbox during removal/refitting. Always use guide pins in pairs.
Guide for reduction gear	3HACxxx Used to guide axis-1 gear and frame during refitting.
Standard toolkit	Content is defined in section <a href="#">Standard tools on page 398</a> .
Other tools and procedures may be required. See references to these procedures in the step-by-step instructions below.	These procedures include references to the tools required.

#### Additional equipment - Foundry Prime

Equipment	Art. no.	Note
Rust preventive	3HAC034903-001	Mercasol
Sikaflex 521FC	3HAC026759-001	
Loctite 574	12340011-116	
Brush		
Foundry Prime touch up kit	3HAC035355-001	

#### Deciding calibration routine

Decide which calibration routine to be used, based on the information in the table. Depending on which routine is chosen, action might be required prior to beginning the repair work of the robot, see the table.

	Action	Note
1	Decide which calibration routine to use for calibrating the robot. <ul style="list-style-type: none"> <li>Reference calibration. External cable packages (DressPack) and tools can stay fitted on the robot.</li> <li>Fine calibration. All external cable packages (DressPack) and tools must be removed from the robot.</li> </ul>	

*Continues on next page*

Action	Note
<p><b>If the robot is to be calibrated with reference calibration:</b> Find previous reference values for the axis or create new reference values. These values are to be used after the repair procedure is completed, for calibration of the robot.</p> <p>If no previous reference values exist, and no new reference values can be created, then reference calibration is not possible.</p>	<p>Follow the instructions given in the reference calibration routine on the FlexPendant to create reference values.</p> <p>Creating new values requires possibility to move the robot.</p> <p>Read more about reference calibration for Axis Calibration in <a href="#">Reference calibration routine on page 368</a>.</p> <p>Read more about reference calibration for Pendulum Calibration in <i>Operating manual - Calibration Pendulum</i>.</p>
<p><b>If the robot is to be calibrated with fine calibration:</b> Remove all external cable packages (DressPack) and tools from the robot.</p>	

#### Illustration of robot put down on its side

The robot is put down on its side for a safe removal of the axis-1 gearbox. Prepare an area on the floor with cardboard, plastic foam or similar and prepare higher support for the wrist.

Make sure the cabling brackets on the lower arm are unfastened and moved out of the way so that the cabling is not getting squeezed.

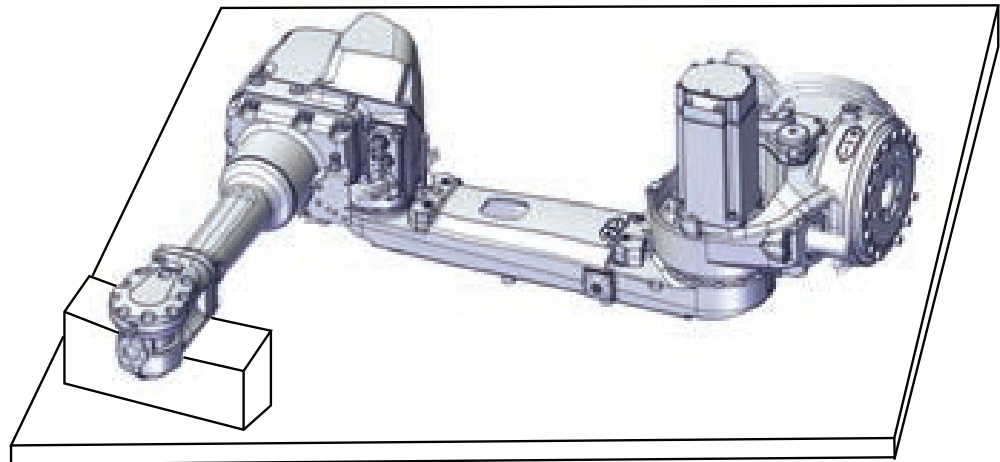

xx1800000593

#### Removing gearbox axis 1

Use this procedure to remove the gearbox.

Action	Note
1	Decide which calibration routine to use, and take actions accordingly prior to beginning the repair procedure.
2	Drain the oil from the gearbox.

How to drain the oil from the gearbox is described in section:



- [Changing the oil, axis 1 gearbox on floor mounted robots on page 153](#)

*Continues on next page*



## 4 Repair

### 4.8.1 Replacing gearbox axis 1

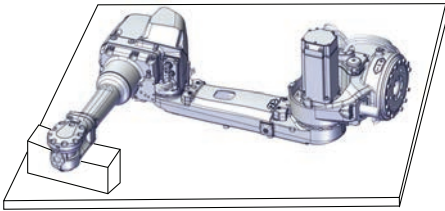
Continued

	Action	Note
3	Jog the robot to: <ul style="list-style-type: none"><li>• Axis 1: 0°</li><li>• Axis 2: 0°</li><li>• Axis 3: -10°</li><li>• Axis 4: 0°</li><li>• Axis 5: 0°</li><li>• Axis 6: 0°</li></ul>	
4	 <b>DANGER</b> Turn off all: <ul style="list-style-type: none"><li>• electric power supply</li><li>• hydraulic pressure supply</li></ul> to the robot, before entering the safeguarded space.	
5	 <b>CAUTION</b> Always cut the paint with a knife and grind the paint edge when disassembling parts. See <a href="#">Cut the paint or surface on the robot before replacing parts on page 200</a> .	
6	Remove the axis-1 motor.	See <a href="#">Removing motors on page 304</a> .
7	Remove the complete arm system from the base and lay down the robot on its side.	See <a href="#">Removing the base on page 258</a> .  xx1800000593

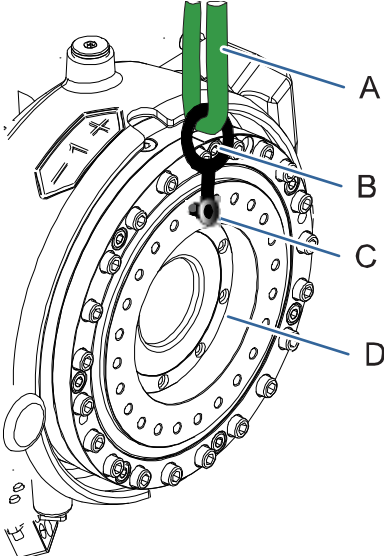
Continues on next page

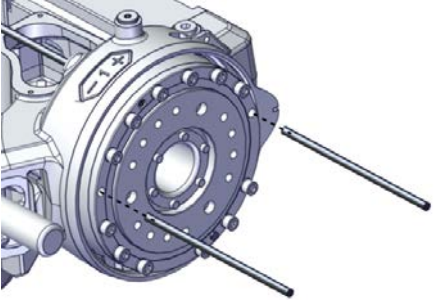



	Action	Note
8	Fit a lifting lug in the uppermost hole for the base attachment screws.	 <p>xx080000440</p> <p>A Roundsling B Lifting lug C Uppermost base attachment hole D Axis-1 gearbox</p>
9	 <b>CAUTION</b> The gearbox weighs 27 kg. All lifting accessories used must be sized accordingly!	
10	Secure the gearbox in an overhead crane or similar.	
11	Remove the <i>attachment screws</i> securing the gearbox.	See the figure in: <ul style="list-style-type: none"> <li>• <a href="#">Location of gearbox on page 325</a></li> </ul>
12	Remove two gearbox attachment screws opposite to each other and fit two guide pins into the holes.	 <p>xx180000789</p> <p>Guide pin, M8x150: 3HAC15520-2 Always use guide pins in pairs!</p>

Continues on next page

## 4 Repair

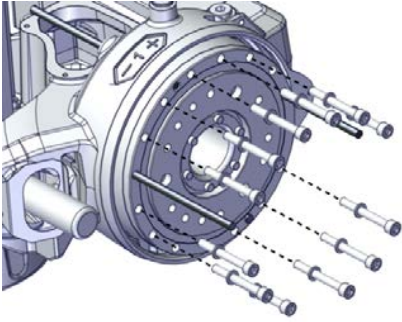
### 4.8.1 Replacing gearbox axis 1

Continued

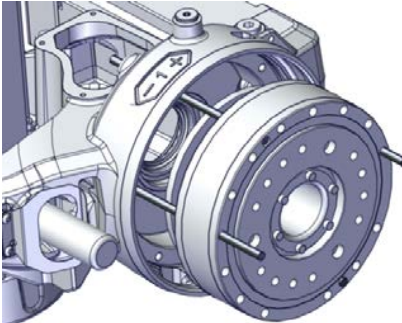
	Action	Note
13	Remove the remaining attachment screws and washers.	 xx180000790
14	 <b>Note</b> Whenever parting/mating motor and gearbox, the gears may be damaged if excessive force is used!	
15	 <b>Note</b> There will be some excess oil running out of the gearbox when it is removed. Use some absorbent material to catch the oil.	
16	Slide the gearbox out onto the guide pins and lift it away. If necessary use removal tools to remove the gearbox.	 <b>Note</b> Always use removal tools in pairs diagonal to each other.  xx180000791

Continues on next page

Refitting gearbox axis 1

Use these procedures to refit the gearbox.

Refitting the gearbox to the frame

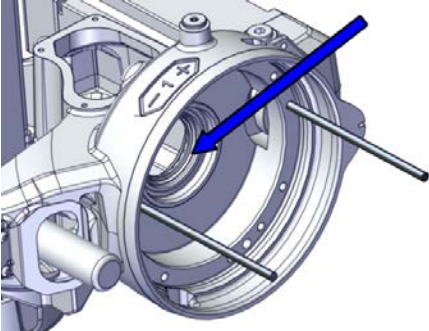
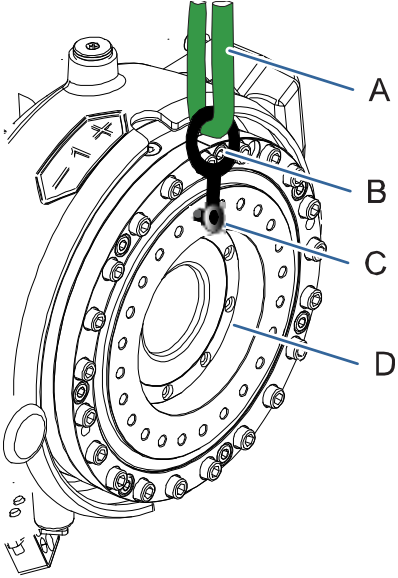
	Action	Note
1	 <b>DANGER</b> Turn off all: <ul style="list-style-type: none"> <li>• electric power supply</li> <li>• hydraulic pressure supply</li> </ul> to the robot, before entering the robot working area.	
2	Clean the joints that have been opened. See <a href="#">Cut the paint or surface on the robot before replacing parts on page 200</a>	
3	Check the radial sealing in the frame. Replace if damaged.	 <p>xx1800000794</p>
4	Fit a lifting lug in the uppermost hole for the base attachment screws.	 <p>xx0800000440</p> <p>A Roundsling                      B Lifting lug                      C Uppermost base attachment hole                      D Axis-1 gearbox</p>

Continues on next page

## 4 Repair

### 4.8.1 Replacing gearbox axis 1

Continued

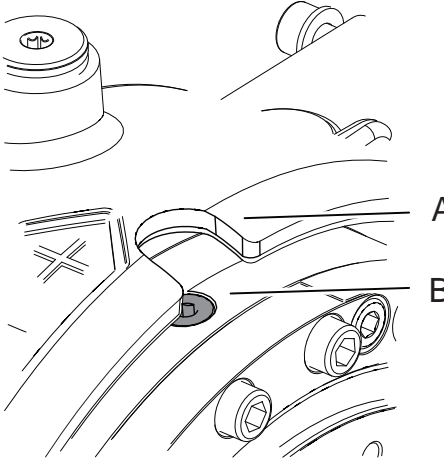
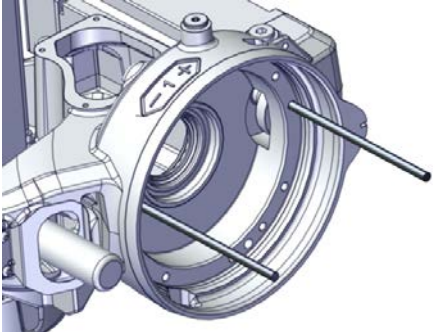
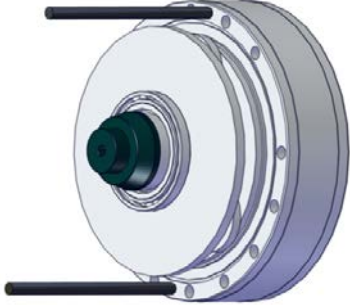
	Action	Note
5	<p> <b>Note</b></p> <p>Check, when fitting the lifting lug, that <b>both oil plugs</b> will be placed in the correct position after the gearbox is fitted as shown in the figure. The oil plugs shall be placed in the <b>openings</b> in the frame.</p>	 <p>xx080000441</p> <p>A Opening for oil plug in frame B Oil plug</p>
6	Apply grease on the <i>o-ring</i> .	<p>See the figure in:</p> <ul style="list-style-type: none"> <li>• <a href="#">Location of gearbox on page 325</a></li> </ul> <p>Replace o-ring if damaged.</p>
7	Clean all assembly surfaces. Remove any painting from the assembly surfaces, with a knife.	
8	Fit two guide pins to the frame.	 <p>xx180000793</p> <p>Guide pin, M8x150: 3HAC15520-2 Always use guide pins in pairs!</p>
9	Fit the guide for the gear on top of the protection tube. It protects the radial sealing from being damaged during refitting.	<p>Guide for reduction gear: 3HACxxx.</p>  <p>xx180000795</p>

Continues on next page

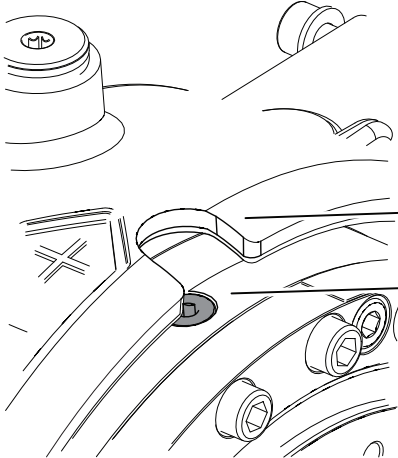
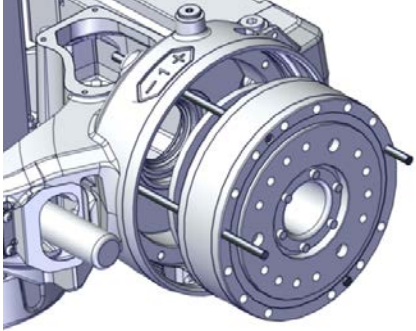
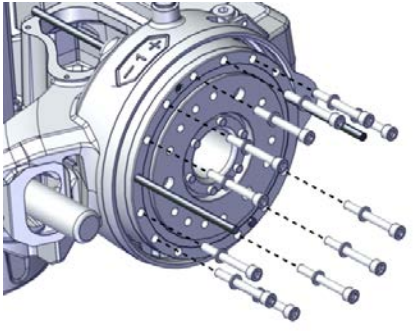
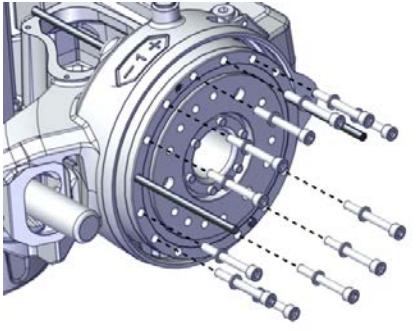

	Action	Note
10	<p> <b>CAUTION</b></p> <p>The gearbox weighs 27 kg. All lifting accessories used must be sized accordingly!</p>	
11	<p>Lift the gearbox onto the guide pins and slide it into position, using caution. Check that the radial sealing in the frame tube does not get damaged. Double check that the oil plugs are in the correct position.</p>  <p>xx0800000441</p> <p>A Opening for oil plug in frame B Oil plug</p>	 <p>xx1800000791</p>
12	Secure the gearbox with its attachment screws and washers.	
13	Remove the guide pins from the frame and secure the remaining two screws.	 <p>xx1800000790</p> <ul style="list-style-type: none"> <li>• 35 Nm</li> </ul>

Continues on next page

## 4 Repair

### 4.8.1 Replacing gearbox axis 1

Continued

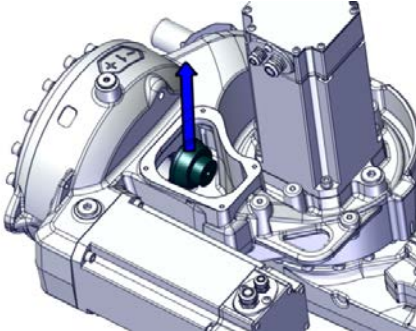
	Action	Note
14	Remove the guide from the protection tube.	 <p>xx1800000796</p>

#### Refitting the arm system to the base

	Action	Note
1	Refit the complete arm system to the base.	See <a href="#">Refitting the base on page 262</a> .
2	Refit the axis-1 motor.	See <a href="#">Refitting motors on page 313</a> .
3	Refit the cable harness in the base, the frame and the lower arm.	Also see <ul style="list-style-type: none"> <li>• <a href="#">Refitting the cable harness in the base on page 223</a></li> <li>• <a href="#">Refitting the cable harness in the frame on page 219</a></li> <li>• <a href="#">Refitting the cable harness in the lower arm and armhouse on page 229</a></li> </ul>
4	Refill oil in the gearbox.	See <a href="#">Changing the oil, axis 1 gearbox on floor mounted robots on page 153</a> .
5	Seal and paint the joints that have been opened. Also repair possible damages of the special Foundry Prime paint coat of the robot. See <a href="#">Cut the paint or surface on the robot before replacing parts on page 200</a> .	
6	Recalibrate the robot.	Pendulum Calibration is described in <a href="#">Operating manual - Calibration Pendulum</a> , enclosed with the calibration tools. Axis Calibration is described in <a href="#">Calibrating with Axis Calibration method on page 367</a> . General calibration information is included in section <a href="#">Calibration on page 353</a> .
7	 <b>DANGER</b> Make sure all safety requirements are met when performing the first test run.	

## 4.8.2 Replacing gearbox axis 2

### Location of gearbox axis 2

The gearbox is located as shown in the figure.

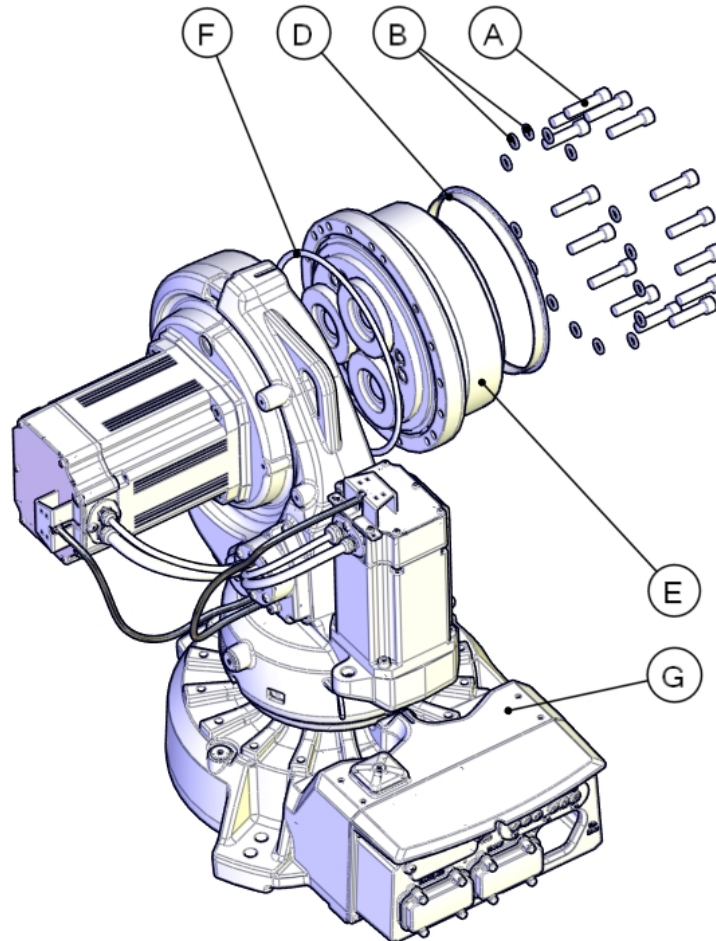

xx110000006

A	Attachment screws M12x50 quality Steel 12.9 Gleitmo (15 pcs)
B	Washers (15 pcs)
D	Sleeve (delivered with gearbox)
E	Gearbox axis 2
F	O-ring
G	Frame

*Continues on next page*

## 4 Repair

### 4.8.2 Replacing gearbox axis 2

Continued

#### Required equipment

Equipment	Article number	Note
Gearbox	See <a href="#">Spare part lists on page 403</a> .	
Rotation tool	3HAB7887-1	
Lifting accessories	-	Roundslings.
Guide pin, M12x150	3HAC13056-2	Always use guide pins in pairs.
Standard toolkit		Content is defined in section <a href="#">Standard tools on page 398</a> .
Other tools and procedures may be required. See references to these procedures in the step-by-step instructions below.		These procedures include references to the tools required.

#### Additional equipment - Foundry Prime

Equipment	Art. no.	Note
Rust preventive	3HAC034903-001	Mercasol
Sikaflex 521FC	3HAC026759-001	
Loctite 574	12340011-116	
Brush		
Foundry Prime touch up kit	3HAC035355-001	

#### Deciding calibration routine

Decide which calibration routine to be used, based on the information in the table. Depending on which routine is chosen, action might be required prior to beginning the repair work of the robot, see the table.

	Action	Note
1	Decide which calibration routine to use for calibrating the robot. <ul style="list-style-type: none"><li>Reference calibration. External cable packages (DressPack) and tools can stay fitted on the robot.</li><li>Fine calibration. All external cable packages (DressPack) and tools must be removed from the robot.</li></ul>	
	<b>If the robot is to be calibrated with reference calibration:</b> Find previous reference values for the axis or create new reference values. These values are to be used after the repair procedure is completed, for calibration of the robot. If no previous reference values exist, and no new reference values can be created, then reference calibration is not possible.	Follow the instructions given in the reference calibration routine on the FlexPendant to create reference values. Creating new values requires possibility to move the robot. Read more about reference calibration for Axis Calibration in <a href="#">Reference calibration routine on page 368</a> . Read more about reference calibration for Pendulum Calibration in <a href="#">Operating manual - Calibration Pendulum</a> .

Continues on next page

Action	Note
<p><b>If the robot is to be calibrated with fine calibration:</b> Remove all external cable packages (DressPack) and tools from the robot.</p>	

**Removing gearbox axis 2**

Use this procedure to remove the gearbox.



**WARNING**

The procedure details how to replace the gearbox without removing the cable harness, only by loosening it. This means that the upper and lower arm will be separated from the frame but still be connected to the frame through the cabling. Be careful not to damage the cables!

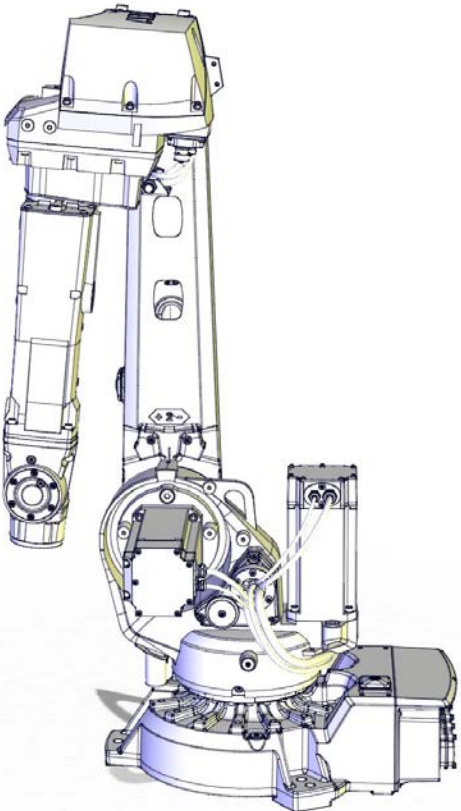



Action	Note
1	Decide which calibration routine to use, and take actions accordingly prior to beginning the repair procedure.
2	<p>Move the robot to the position shown in the figure. Upper arm should rest on the axis-3 damper.</p>  <p>xx120000068</p>

Continues on next page

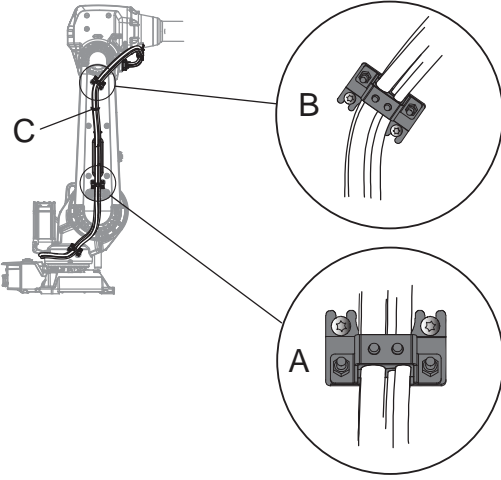

## 4 Repair

### 4.8.2 Replacing gearbox axis 2

Continued

	Action	Note
3	 <b>DANGER</b> Turn off all: <ul style="list-style-type: none"> <li>• electric power supply</li> <li>• hydraulic pressure supply</li> </ul> to the robot, before entering the robot working area.	
4	Drain the gearbox.	How to drain the gearbox is described in section: <ul style="list-style-type: none"> <li>• <a href="#">Changing the oil, axis-2 gearbox on page 165</a></li> </ul>
5	 <b>CAUTION</b> Always cut the paint with a knife and grind the paint edge when disassembling parts. See <a href="#">Cut the paint or surface on the robot before replacing parts on page 200</a> .	
6	Loosen the cabling from the lower arm by removing two cable brackets and a cable strap.	 <p>xx1100000946</p> <p>A Cable bracket            B Cable bracket            C Cable strap</p>
7	 <b>CAUTION</b> The weight of the complete upper and lower arm together is 205 kg All lifting accessories used must be sized accordingly.	
8	Attach a roundsling around the upper arm house.	

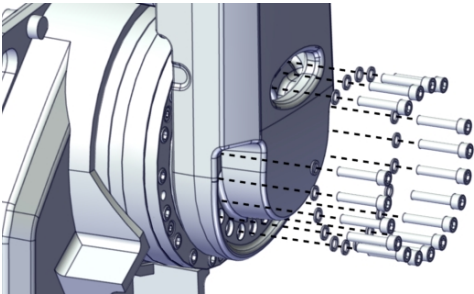
Continues on next page



	Action	Note
9	Unload the weight of the lower and upper arm package by stretching the roundslings with the overhead crane. Turn on the power temporarily and release the brakes of axis 2 to rest the weight onto the roundslings.	
10	 <b>DANGER</b> Turn off all: <ul style="list-style-type: none"> <li>• electric power supply</li> <li>• hydraulic pressure supply</li> </ul> to the robot, before entering the robot working area.	
11	Remove the <i>attachment screws and washers</i> that secure the lower arm to the axis-2 gearbox.	 <p>xx1800000935</p>
12	Remove the lower and upper arm package from the frame.  <b>WARNING</b> The cable harness is still installed on the robot! Make sure not to damage the cables or the cable brackets on the robot.	
13	 <b>CAUTION</b> The gearbox weighs 51 kg All lifting accessories used must be sized accordingly!	

Continues on next page

## 4 Repair

### 4.8.2 Replacing gearbox axis 2

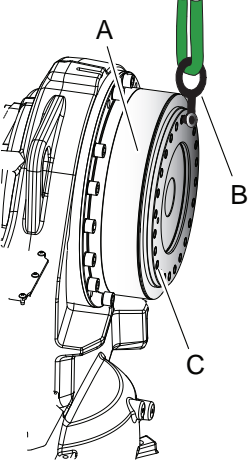
Continued

Action	Note
<p>14 Fit a <i>lifting lug</i> in the uppermost hole for the attachment screws that secure the lower arm to the gearbox.</p>	 <p>xx0800000445</p> <p>Parts:</p> <ul style="list-style-type: none"> <li>• A: Gearbox axis 2</li> <li>• B: Lifting lug</li> <li>• C: Holes for attachment screws that secure the lower arm to the axis-2 gearbox</li> </ul>
<p>15 Secure the gearbox with a roundsling in an overhead crane or similar.</p>	
<p>16 Remove the <i>attachment screws and washers</i> that secure the gearbox to the frame.</p>	<p>See the figure in:</p> <ul style="list-style-type: none"> <li>• <a href="#">Location of gearbox axis 2 on page 335</a></li> </ul>
<p>17 Fit guide pins to help guiding the gearbox out from the frame.</p>	<p>Guide pin, M12x150: 3HAC13056-2 Always use guide pins in pairs.</p>
<p>18 If necessary, use removal tools to remove the gearbox.</p>	 <p><b>Note</b></p> <p>Always use removal tools in pairs diagonal to each other.</p>
<p>19 Remove the gearbox.</p> <p> <b>CAUTION</b></p> <p>Use caution in order not to damage gearbox or pinion!</p>	



### Refitting gearbox axis 2

Use this procedure to refit the gearbox.

Action	Note
<p>1</p> <p> <b>DANGER</b></p> <p>Turn off all:</p> <ul style="list-style-type: none"> <li>• electric power supply</li> <li>• hydraulic pressure supply</li> </ul> <p>to the robot, before entering the robot working area.</p>	

Continues on next page



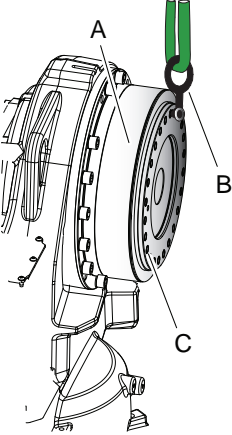

	Action	Note
2	<p> <b>CAUTION</b></p> <p>Always cut the paint with a knife and grind the paint edge when disassembling parts. See <a href="#">Cut the paint or surface on the robot before replacing parts on page 200</a>.</p>	
3	<p> <b>CAUTION</b></p> <p>The gearbox weighs 51 kg All lifting accessories used must be sized accordingly!</p>	
4	<p>Fit a <b>lifting lug</b> in the uppermost hole for the attachment screws securing the lower arm to the gearbox.</p>	 <p>xx0800000445</p> <p><b>Parts:</b></p> <ul style="list-style-type: none"> <li>• A: Gearbox axis 2</li> <li>• B: Lifting lug</li> <li>• C: Holes for attachment screws securing the lower arm to gearbox axis 2.</li> </ul>
5	<p>Clean all assembly surfaces. Remove any painting from the assembly surfaces, with a knife.</p>	
6	<p>Apply some grease on the o-ring before fitting.</p>	<p>See the figure in:</p> <ul style="list-style-type: none"> <li>• <a href="#">Location of gearbox axis 2 on page 335</a></li> </ul>
7	<p>Fit two guide pins in opposite holes in the frame.</p>	<p>Guide pin, M12x150: 3HAC13056-2 Always use guide pins in pairs.</p>
8	<p>Secure the gearbox with a roundsling in an overhead crane or similar.</p>	
9	<p>Release the brakes of the axis 2 motor.</p>	

Continues on next page

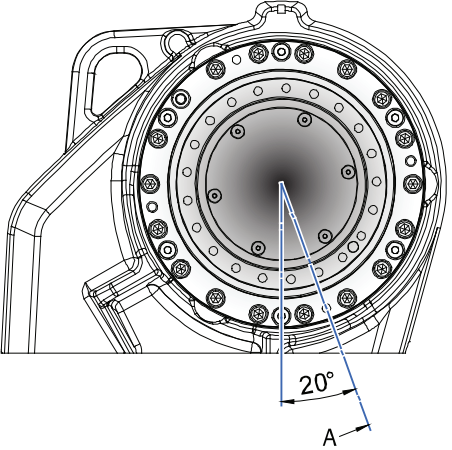

## 4 Repair

### 4.8.2 Replacing gearbox axis 2

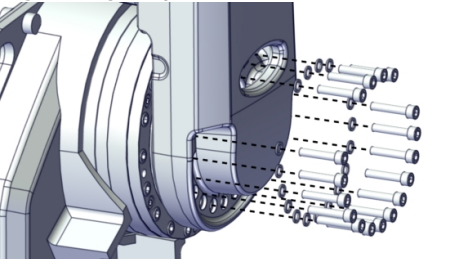
Continued

	Action	Note
10	<p>Lift the gearbox onto the guide pins and slide it into position while rotating the motor pinion to find the mating position. Use a <i>rotation tool</i>.</p> <p> <b>Note</b></p> <p>The position of the oil plug shall be according to the illustration.</p>	<p>Article number is specified in <a href="#">Required equipment on page 336</a>.</p>  <p>xx1000000307</p> <p><b>Parts:</b></p> <ul style="list-style-type: none"> <li>• A: Position of oil plug on gearbox</li> </ul>
11	<p>Secure the gearbox with its <i>attachment screws and washers</i>.</p>	<p>See screw dimension in the figure in:</p> <ul style="list-style-type: none"> <li>• <a href="#">Location of gearbox axis 2 on page 335</a></li> </ul> <p>Tightening torque: 110 Nm</p>
12	<p>Perform a leak-down test.</p>	<p>See <a href="#">Performing a leak-down test on page 194</a>.</p>
13	<p>Fit the guide pins to the gearbox.</p>	
14	<p> <b>CAUTION</b></p> <p>The weight of the complete upper and lower arm together is 205 kg</p> <p>All lifting accessories used must be sized accordingly.</p>	
15	<p>Lift the upper and lower arms into mounting position and guide them in place with the guide pins.</p> <p>It might be necessary to rotate the motor pinion with the rotating tool to find the mating position.</p>	
16	<p>Refit the <i>attachment screws and washers</i> to secure the lower arm to the axis-2 gearbox.</p>	<p>Attachment screws: M12x50 quality steel Gleitmo 12.9 (18 pcs)</p> <p>Tightening torque: 110 Nm.</p>  <p>xx1800000935</p>

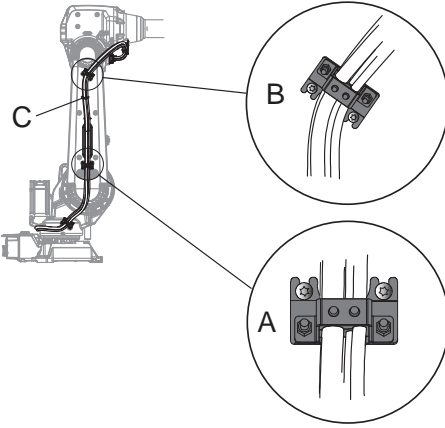
Continues on next page

	Action	Note
17	Refit the cable brackets and cable strap to the lower arm.	 <p data-bbox="986 741 1093 757">xx1100000946</p> <p data-bbox="1018 779 1214 869"> <b>A</b> Cable bracket  <b>B</b> Cable bracket  <b>C</b> Cable strap </p>
18	Refill the gearbox with <i>lubrication oil</i> .	<p data-bbox="986 891 1390 943">How to fill the gearbox with oil is described in section:</p> <ul data-bbox="1018 943 1422 994" style="list-style-type: none"> <li>• <a href="#">Changing the oil, axis-2 gearbox on page 165</a></li> </ul>
19	Seal and paint the joints that have been opened. Also repair possible damages of the special Foundry Prime paint coat of the robot. See <a href="#">Cut the paint or surface on the robot before replacing parts on page 200</a> .	
20	Recalibrate the robot.	<p data-bbox="986 1173 1437 1249">Pendulum Calibration is described in <i>Operating manual - Calibration Pendulum</i>, enclosed with the calibration tools.</p> <p data-bbox="986 1256 1437 1308">Axis Calibration is described in <a href="#">Calibrating with Axis Calibration method on page 367</a>.</p> <p data-bbox="986 1314 1437 1368">General calibration information is included in section <a href="#">Calibration on page 353</a>.</p>
21	 <p data-bbox="592 1429 703 1451"><b>DANGER</b></p> <p data-bbox="501 1480 970 1532">Make sure all safety requirements are met when performing the first test run.</p>	

## 4 Repair

### 4.8.3 Replacing gearbox axis 3

### 4.8.3 Replacing gearbox axis 3

#### Location of gearbox axis 3

The gearbox is located as shown in the figure.

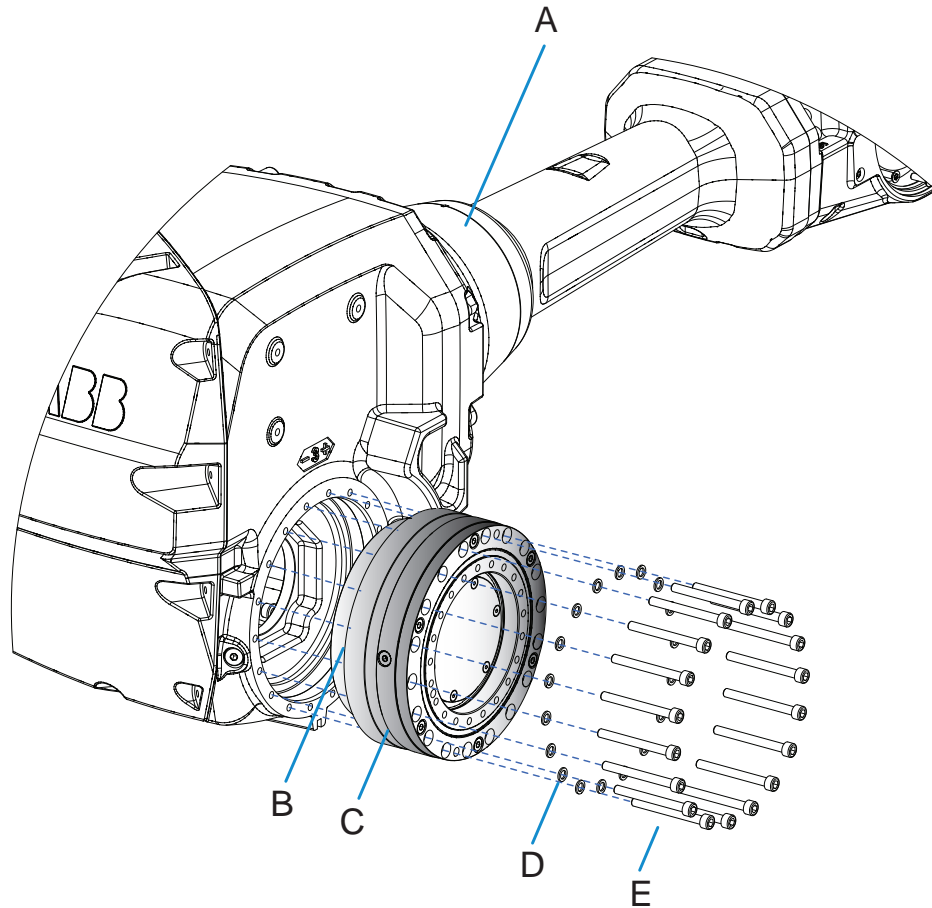

xx0800000398

A	Upper arm
B	O-ring
C	Axis-3 gearbox
D	Washers (18 pcs)
E	Attachment screws M8x80 quality Steel 12.9 Gleitmo (18 pcs)

#### Required equipment

Equipment	Art. no.	Note
Gearbox		See <a href="#">Spare part lists on page 403</a> .
Guide pins		M8 (2 pcs) Used to guide the gearbox and the upper arm during removal/refitting.
Rotation tool	3HAB7887-1	

*Continues on next page*

Equipment	Art. no.	Note
Standard toolkit		Content is defined in section <a href="#">Standard tools on page 398</a> .
Other tools and procedures may be required. See references to these procedures in the step-by-step instructions below.		These procedures include references to the tools required.

#### Additional equipment - Foundry Prime

Equipment	Art. no.	Note
Rust preventive	3HAC034903-001	Mercasol
Sikaflex 521FC	3HAC026759-001	
Loctite 574	12340011-116	
Brush		
Foundry Prime touch up kit	3HAC035355-001	

#### Deciding calibration routine

Decide which calibration routine to be used, based on the information in the table. Depending on which routine is chosen, action might be required prior to beginning the repair work of the robot, see the table.

	Action	Note
1	<p>Decide which calibration routine to use for calibrating the robot.</p> <ul style="list-style-type: none"> <li>Reference calibration. External cable packages (DressPack) and tools can stay fitted on the robot.</li> <li>Fine calibration. All external cable packages (DressPack) and tools must be removed from the robot.</li> </ul>	
	<p><b>If the robot is to be calibrated with reference calibration:</b></p> <p>Find previous reference values for the axis or create new reference values. These values are to be used after the repair procedure is completed, for calibration of the robot.</p> <p>If no previous reference values exist, and no new reference values can be created, then reference calibration is not possible.</p>	<p>Follow the instructions given in the reference calibration routine on the FlexPendant to create reference values.</p> <p>Creating new values requires possibility to move the robot.</p> <p>Read more about reference calibration for Axis Calibration in <a href="#">Reference calibration routine on page 368</a>.</p> <p>Read more about reference calibration for Pendulum Calibration in <i>Operating manual - Calibration Pendulum</i>.</p>
	<p><b>If the robot is to be calibrated with fine calibration:</b></p> <p>Remove all external cable packages (DressPack) and tools from the robot.</p>	

Continues on next page

## 4 Repair

### 4.8.3 Replacing gearbox axis 3

Continued



#### Removing gearbox axis 3

Use this procedure to remove the gearbox.







#### WARNING

The procedure details how to replace the gearbox without removing the cable harness. This means that the upper and lower arm will be separated but still be connected to each other through the cabling. Be careful not to damage the cables!

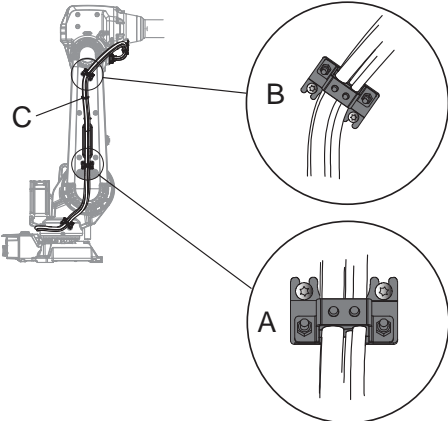
	Action	Note
1	Decide which calibration routine to use, and take actions accordingly prior to beginning the repair procedure.	
2	Drain the gearbox.	How to drain the gearbox is described in section: <ul style="list-style-type: none"><li>• <a href="#">Changing the oil, axis-3 gearbox on page 169</a></li></ul>
3	Move the robot to the position shown in the figure.	 xx0800000336
4	 <b>DANGER</b> Turn off all: <ul style="list-style-type: none"><li>• electric power supply</li><li>• hydraulic pressure supply</li></ul> to the robot, before entering the robot working area.	
5	 <b>CAUTION</b> Always cut the paint with a knife and grind the paint edge when disassembling parts. See <a href="#">Cut the paint or surface on the robot before replacing parts on page 200</a> .	

Continues on next page







	Action	Note
6	<p>Unscrew the attachment screws securing the cable harness to the lower arm by the the two cable brackets and a cable strap.</p>	 <p>xx1100000946</p> <p>A Cable bracket B Cable bracket C Cable strap</p>
7	<p>Loosen the cabling from the lower arm by unhooking the two cable brackets.</p> <p> <b>CAUTION</b></p> <p>The cable harness is still mounted in other parts of the robot. Make sure not to damage the cable harness or any cable brackets in the continued removal.</p>	
8	<p>Attach the lifting accessories to the upper arm.</p>	<p>See <a href="#">Attaching the lifting accessories to the upper arm on page 271</a></p>
9	<p>Connect the 24 VDC power supply to the axis-3 motor and release the brakes.</p>	
10	<p>Releasing the brakes of the axis-3 motor unloads the weight of the upper arm by stretching the roundslings.</p>	
11	<p>Remove the <i>attachment screws</i> that secure the upper arm to the lower arm.</p> <p> <b>Note</b></p> <p>Do not remove the attachment screws securing the gearbox axis 3 to the armhouse!</p>	<p>See the figure in:</p> <ul style="list-style-type: none"> <li><a href="#">Location of the complete upper arm on page 266</a></li> </ul>
12	<p> <b>CAUTION</b></p> <p>The robot upper arm weighs 140 kg. All lifting accessories used must be sized accordingly!</p>	

Continues on next page

## 4 Repair

### 4.8.3 Replacing gearbox axis 3

Continued

	Action	Note
13	<p>Remove the upper arm from the lower arm and leave it hanging in the air.</p> <p> <b>CAUTION</b></p> <p>When the upper arm no longer is attached to the robot, the armhouse has a tendency to drop down a little. In order to prevent this is to rise the front end of the upper arm a little before removing the attachment screws securing the upper arm.</p>	<p> <b>WARNING</b></p> <p>The cable harness is still installed on the robot! Make sure not to damage the cable harness or the cable brackets on the robot.</p>
14	<p> <b>CAUTION</b></p> <p>The gearbox weighs 23 kg. All lifting accessories used must be sized accordingly!</p>	
15	Remove two attachment screws diagonally located and insert guide pins.	Always use guide pins in pairs!
16	Remove the remaining <i>attachment screws</i> that secures the gearbox.	See the figure in: <ul style="list-style-type: none"> <li><a href="#">Location of gearbox axis 3 on page 344</a></li> </ul>
17	<p> <b>Note</b></p> <p>There will be some surplus oil in the gearbox. Place some absorbant cloth or similar under the gearbox.</p>	
18	<p>Slide the gearbox carefully out onto the guide pins and lift it away. If necessary, use a pair of screws to push out the gearbox.</p> <p> <b>CAUTION</b></p> <p>Remaining oil will drain out from the gearbox cavity when the gearbox is lifted out.</p>	<p> <b>Note</b></p> <p>Always use removal tools in pairs diagonal to each other.</p>





### Refitting the gearbox axis 3

Use this procedure to refit the gearbox.

	Action	Note
1	<p> <b>DANGER</b></p> <p>Turn off all:</p> <ul style="list-style-type: none"> <li>electric power supply</li> <li>hydraulic pressure supply</li> </ul> <p>to the robot, before entering the robot working area.</p>	

Continues on next page



	Action	Note
2	 <b>CAUTION</b> Always cut the paint with a knife and grind the paint edge when disassembling parts. See <a href="#">Cut the paint or surface on the robot before replacing parts on page 200</a> .	
3	 <b>CAUTION</b> The gearbox weighs 23 kg. All lifting accessories used must be sized accordingly!	
4	Clean all assembly surfaces. Remove any painting or other contamination from the assembly surfaces, with a knife.	
5	Apply some grease on the o-ring before fitting it to the gearbox.	See the figure in: <ul style="list-style-type: none"> <li>• <a href="#">Location of gearbox axis 3 on page 344</a></li> </ul>
6	Fit two guide pins in two opposite screw holes in the upper arm.	Always use guide pins in pairs!
7	Remove the arm house cover.	
8	Attach the rotation tool on the axis-3 motor.	
9	Release the brakes of the axis 3 motor.	
10	Lift the gearbox onto the guide pins.	
11	 <b>Note</b> Whenever parting/mating motor and gearbox, the gears may be damaged if excessive force is used!	
12	Slide the gearbox into position while rotating the motor pinion to find the mating position. Use a <i>rotation tool</i> .   <b>Tip</b> Two persons are required for this step since the upper arm is hanging freely in the air. One person needs to hold the upper arm still while the other fits the gearbox into the upper arm.	Article number for the rotation tool is specified in <a href="#">Required equipment on page 344</a> .
13	Rotate the motor pinion and slide the gearbox into position.	
14	Secure the gearbox with its <i>attachment screws</i> and <i>washers</i> .	See the figure in: <ul style="list-style-type: none"> <li>• <a href="#">Location of gearbox axis 3 on page 344</a></li> </ul> Tightening torque: 35 Nm.
15	Remove the guide pins and replace them with the remaining attachment screws.	

Continues on next page



## 4 Repair

### 4.8.3 Replacing gearbox axis 3

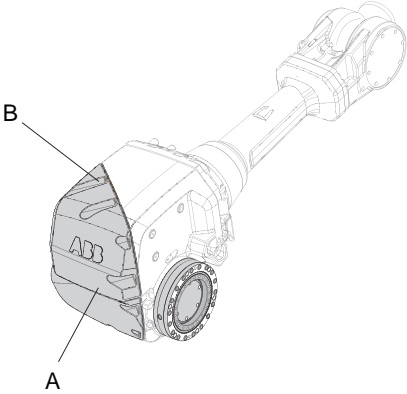
Continued

	Action	Note
16	Perform a leak-down test.	See <a href="#">Performing a leak-down test on page 194</a> .
17	Fit <i>guide pins</i> in the upper arm.	Specified in <a href="#">Required equipment on page 344</a> .
18	Move the upper arm to its mounting position. (With the brakes of the axis 3 motor still released.)	
19	Refit the upper arm to the lower arm with its <i>attachment screws</i> .	See the figure in: <ul style="list-style-type: none"> <li><a href="#">Location of the complete upper arm on page 266</a></li> </ul> Tightening torque: <ul style="list-style-type: none"> <li>35 Nm</li> </ul>
20	Remove the guide pins and replace with the remaining attachment screws.	
21	Remove the 24 VDC power supply.	
22	Refit the upper armhouse cover with its attachment screws and washers.   <b>WARNING</b>  The cover on the armhouse must be fitted when the robot is running. It is a vital part for the stability of the robot.	Tightening torque: 14 Nm. Make sure that the cover is tightly sealed.   xx0800000389  <b>Parts:</b> <ul style="list-style-type: none"> <li>A: Cover</li> <li>B: Attachment screws M6x25, quality 8.8-A2F (10 pcs)</li> </ul>
23	Make sure that the armhouse cover is tightly fitted. If there is a gap between the cover and the robot, seal with Sikaflex 521 FC.	

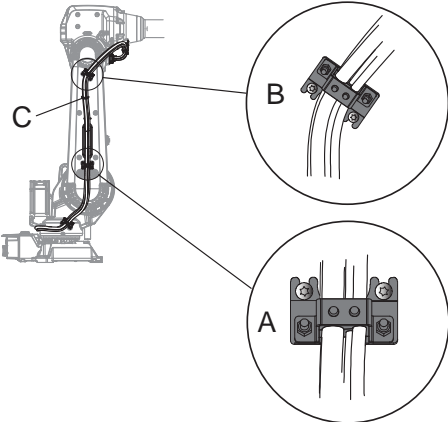
Continues on next page

	Action	Note
24	Refit the two cable brackets and a cable strap to the lower arm.	 <p>xx1100000946</p> <p>A Cable bracket B Cable bracket C Cable strap</p>
25	Refill the gearbox with <i>lubrication oil</i> .	How to fill the gearbox with oil is described in section: <ul style="list-style-type: none"> <li>• <a href="#">Changing the oil, axis-3 gearbox on page 169</a></li> </ul>
26	CSeal and paint the joints that have been opened. Also repair possible damages of the special Foundry Prime paint coat of the robot. See <a href="#">Cut the paint or surface on the robot before replacing parts on page 200</a> .	
27	Recalibrate the robot.	Pendulum Calibration is described in <i>Operating manual - Calibration Pendulum</i> , enclosed with the calibration tools. Axis Calibration is described in <a href="#">Calibrating with Axis Calibration method on page 367</a> . General calibration information is included in section <a href="#">Calibration on page 353</a> .
28	 <p><b>DANGER</b></p> <p>Make sure all safety requirements are met when performing the first test run.</p>	

**This page is intentionally left blank**

## 5 Calibration

### 5.1 Introduction to calibration

#### 5.1.1 Introduction and calibration terminology

##### Calibration information

This chapter includes general information about the recommended calibration methods and also the detailed procedures for updating the revolution counters, checking the calibration position etc.

Detailed instructions of how to perform Axis Calibration are given on the FlexPendant during the calibration procedure. To prepare calibration with Axis Calibration method, see [Calibrating with Axis Calibration method on page 367](#).

Detailed instructions of how to perform Pendulum Calibration are given in the documentation enclosed with the calibration tools.

##### Calibration terminology

Term	Definition
Calibration method	A collective term for several methods that might be available for calibrating the ABB robot. Each method contains calibration routines.
Synchronization position	Known position of the complete robot where the angle of each axis can be checked against visual synchronization marks.
Calibration position	Known position of the complete robot that is used for calibration of the robot.
Standard calibration	A generic term for all calibration methods that aim to move the robot to calibration position.
Fine calibration	A calibration routine that generates a new zero position of the robot.
Reference calibration	<p>A calibration routine that in the first step generates a reference to current zero position of the robot. The same calibration routine can later on be used to recalibrate the robot back to the same position as when the reference was stored.</p> <p>This routine is more flexible compared to fine calibration and is used when tools and process equipment are installed.</p> <p>Requires that a reference is created before being used for recalibrating the robot.</p> <p>Requires that the robot is dressed with the same tools and process equipment during calibration as during creation of the reference values.</p>
Update revolution counter	A calibration routine to make a rough calibration of each manipulator axis.
Synchronization mark	Visual marks on the robot axes. When marks are aligned, the robot is in synchronization position.

## 5 Calibration

### 5.1.2 Calibration methods

### 5.1.2 Calibration methods

#### Overview

This section specifies the different types of calibration and the calibration methods that are supplied by ABB.

#### Types of calibration

Type of calibration	Description	Calibration method
Standard calibration	<p>The calibrated robot is positioned at calibration position.</p> <p>Standard calibration data is found on the SMB (serial measurement board) or EIB in the robot. For robots with RobotWare 5.04 or older, the calibration data is delivered in a file, calib.cfg, supplied with the robot at delivery. The file identifies the correct resolver/motor position corresponding to the robot home position.</p>	Axis Calibration or Calibration Pendulum <sup>i</sup>
Absolute accuracy calibration (optional)	<p>Based on standard calibration, and besides positioning the robot at synchronization position, the Absolute accuracy calibration also compensates for:</p> <ul style="list-style-type: none"> <li>• Mechanical tolerances in the robot structure</li> <li>• Deflection due to load</li> </ul> <p>Absolute accuracy calibration focuses on positioning accuracy in the Cartesian coordinate system for the robot.</p> <p>Absolute accuracy calibration data is found on the SMB (serial measurement board) in the robot.</p> <p>For robots with RobotWare 5.05 or older, the absolute accuracy calibration data is delivered in a file, absacc.cfg, supplied with the robot at delivery. The file replaces the calib.cfg file and identifies motor positions as well as absolute accuracy compensation parameters.</p> <p>A robot calibrated with Absolute accuracy has a sticker next to the identification plate of the robot.</p> <p>A robot calibrated with Absolute accuracy has the option information printed on its name plate.</p> <p>To regain 100% Absolute accuracy performance, the robot must be recalibrated for absolute accuracy after repair or maintenance that affects the mechanical structure.</p> <div style="border: 1px solid black; padding: 5px; margin-top: 10px;">  </div> <p>xx0400001197</p>	CalibWare

*Continues on next page*

Type of calibration	Description	Calibration method
Optimization	<p>Optimization of TCP reorientation performance. The purpose is to improve reorientation accuracy for continuous processes like welding and gluing.</p> <p>Wrist optimization will update standard calibration data for axes 4, 5 and 6.</p>	Wrist Optimization

- <sup>i</sup> The robot is calibrated by either Calibration Pendulum or Axis Calibration at factory. Always use the same calibration method as used at the factory. Information about valid calibration method is found on the calibration label or in the calibration menu on the FlexPendant. If no data is found related to standard calibration, contact the local ABB Service.

### Brief description of calibration methods

#### Calibration Pendulum method

Calibration Pendulum is a standard calibration method for calibration of many of ABB robots (except IRB 6400R, IRB 640, IRB 1400H, and IRB 4400S). This calibration method is not used on OmniCore robots.

Two different routines are available for the Calibration Pendulum method:

- Calibration Pendulum II
- Reference calibration

The calibration equipment for Calibration Pendulum is delivered as a complete toolkit, including the *Operating manual - Calibration Pendulum*, which describes the method and the different routines further.

#### Axis Calibration method

Axis Calibration is a standard calibration method for calibration of IRB 4600 Foundry Prime. It is the recommended method in order to achieve proper performance.

The following routines are available for the Axis Calibration method:

- Fine calibration
- Update revolution counters
- Reference calibration

The calibration equipment for Axis Calibration is delivered as a toolkit.

An introduction to the calibration method is given in this manual, see [Calibrating with Axis Calibration method on page 367](#).

The actual instructions of how to perform the calibration procedure and what to do at each step is given on the FlexPendant. You will be guided through the calibration procedure, step by step.

#### Wrist Optimization method

Wrist Optimization is a method for improving reorientation accuracy for continuous processes like welding and gluing and is a complement to the standard calibration method.

The following routines are available for the Wrist Optimization method:

- Wrist Optimization

Continues on next page

## 5 Calibration

---

### 5.1.2 Calibration methods

*Continued*

The actual instructions of how to perform the calibration procedure and what to do at each step is given on the FlexPendant. You will be guided through the calibration procedure, step by step.

#### CalibWare - Absolute Accuracy calibration

The CalibWare tool guides through the calibration process and calculates new compensation parameters. This is further detailed in the *Application manual - CalibWare Field*.

If a service operation is done to a robot with the option Absolute Accuracy, a new absolute accuracy calibration is required in order to establish full performance. For most cases after replacements that do not include taking apart the robot structure, standard calibration is sufficient.

The Absolute Accuracy option varies according to the robot mounting position. This is printed on the robot name plate for each robot. The robot must be in the correct mounting position when it is recalibrated for absolute accuracy.

---

#### References

Article numbers for the calibration tools are listed in the section [Special tools on page 399](#).

The calibration equipment for Calibration Pendulum is delivered as a complete toolkit, including the *Operating manual - Calibration Pendulum*, which describes the method and the different routines further.



---

### 5.1.3 When to calibrate

---

#### When to calibrate

The system must be calibrated if any of the following situations occur.

#### The resolver values are changed

If resolver values are changed, the robot must be re-calibrated using the calibration methods supplied by ABB. Calibrate the robot carefully with standard calibration, according to information in this manual.

If the robot has *absolute accuracy* calibration, it is also recommended, but not always necessary to calibrate for new absolute accuracy.

The resolver values will change when parts affecting the calibration position are replaced on the robot, for example motors or parts of the transmission.

#### The revolution counter memory is lost

If the revolution counter memory is lost, the counters must be updated. See [Updating revolution counters on page 361](#). This will occur when:

- The battery is discharged
- A resolver error occurs
- The signal between a resolver and measurement board is interrupted
- A robot axis is moved with the control system disconnected

The revolution counters must also be updated after the robot and controller are connected at the first installation.

#### The robot is rebuilt

If the robot is rebuilt, for example, after a crash or when the reachability of a robot is changed, it needs to be re-calibrated for new resolver values.

If the robot has *absolute accuracy* calibration, it needs to be calibrated for new absolute accuracy.

#### Robot is not floor mounted

The original calibration data delivered with the robot is generated when the robot is floor mounted. If the robot is not floor mounted, then the robot accuracy could be affected. The robot needs to be calibrated after it is mounted.

## 5 Calibration

### 5.2.1 Synchronization marks and synchronization position for axes

## 5.2 Synchronization marks and axis movement directions

### 5.2.1 Synchronization marks and synchronization position for axes

#### Introduction

This section shows the position of the synchronization marks and the synchronization position for each axis.

#### Synchronization marks, IRB 4600

IRB 4600-60/2.05

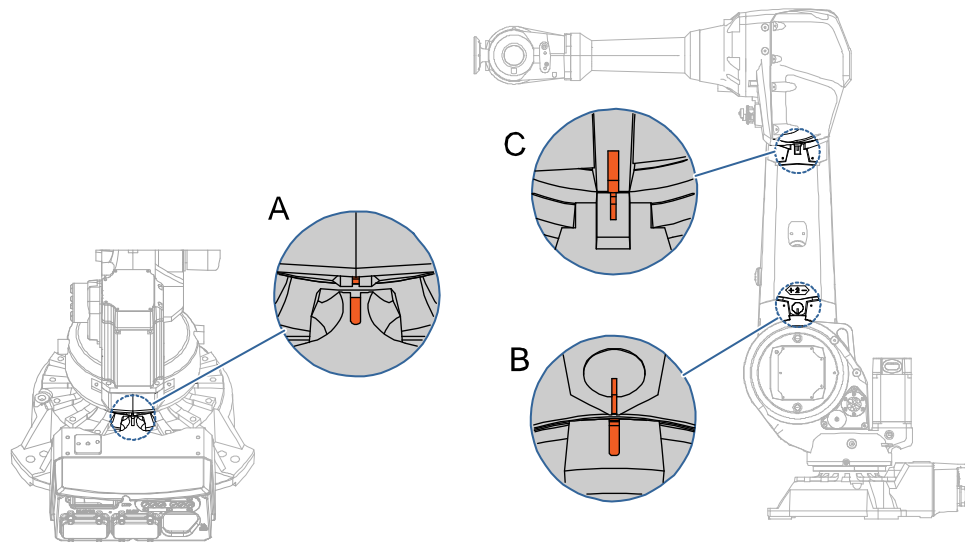

xx0800000312

A	Synchronization mark, axis 1
B	Synchronization mark, axis 2
C	Synchronization mark, axis 3

*Continues on next page*

5.2.1 Synchronization marks and synchronization position for axes  
*Continued*

IRB 4600 - 60/2.05

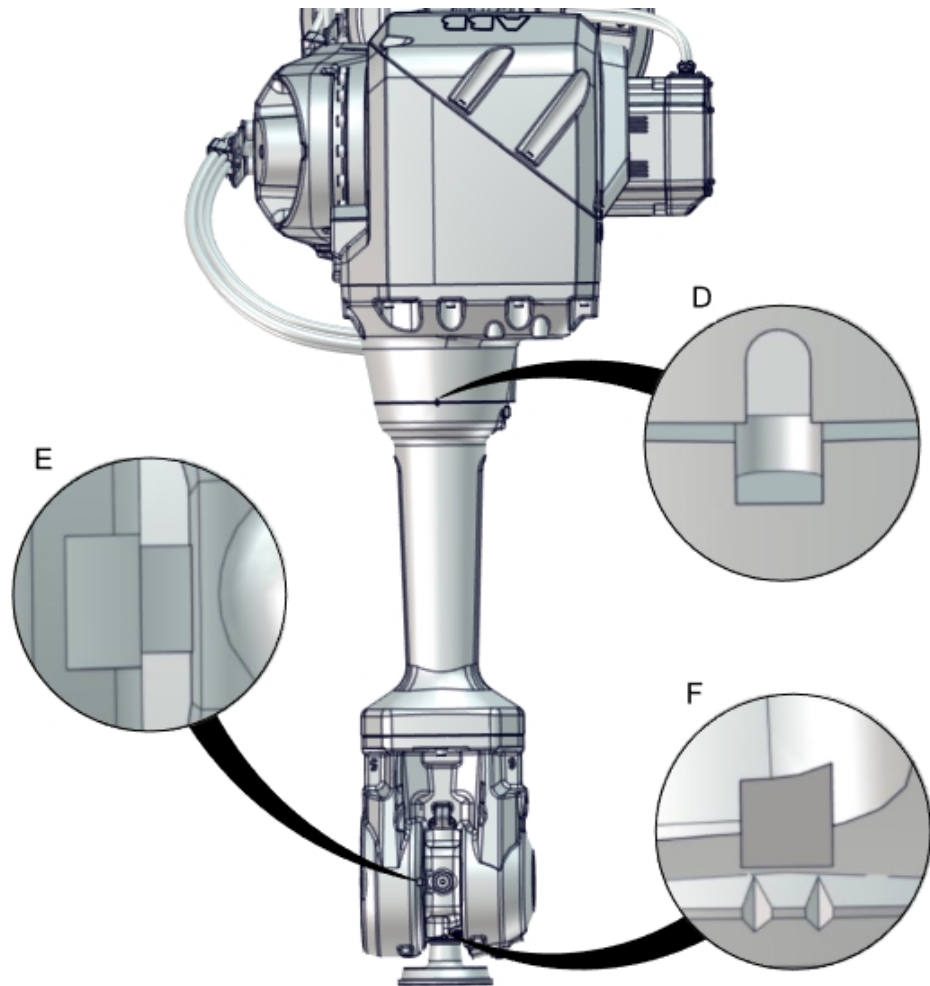

xx1700001814

D	Synchronization mark, axis 4
E	Synchronization mark, axis 5
F	Synchronization mark, axis 6 The two tips of the arrows should be inside the corresponding groove on the tilt housing when in synchronization position.

## 5 Calibration

### 5.2.2 Calibration movement directions for all axes

### 5.2.2 Calibration movement directions for all axes

#### Overview

When calibrating, the axis must consistently be run towards the calibration position in the same direction in order to avoid position errors caused by backlash in gears and so on. Positive directions are shown in the graphic below.

Calibration service routines will handle the calibration movements automatically and these might be different from the positive directions shown below.

#### Manual movement directions, 6 axes

**Note!** The graphic shows an IRB 7600. The positive direction is the same for all 6-axis robots, except the positive direction of axis 3 for IRB 6400R, which is in the opposite direction!

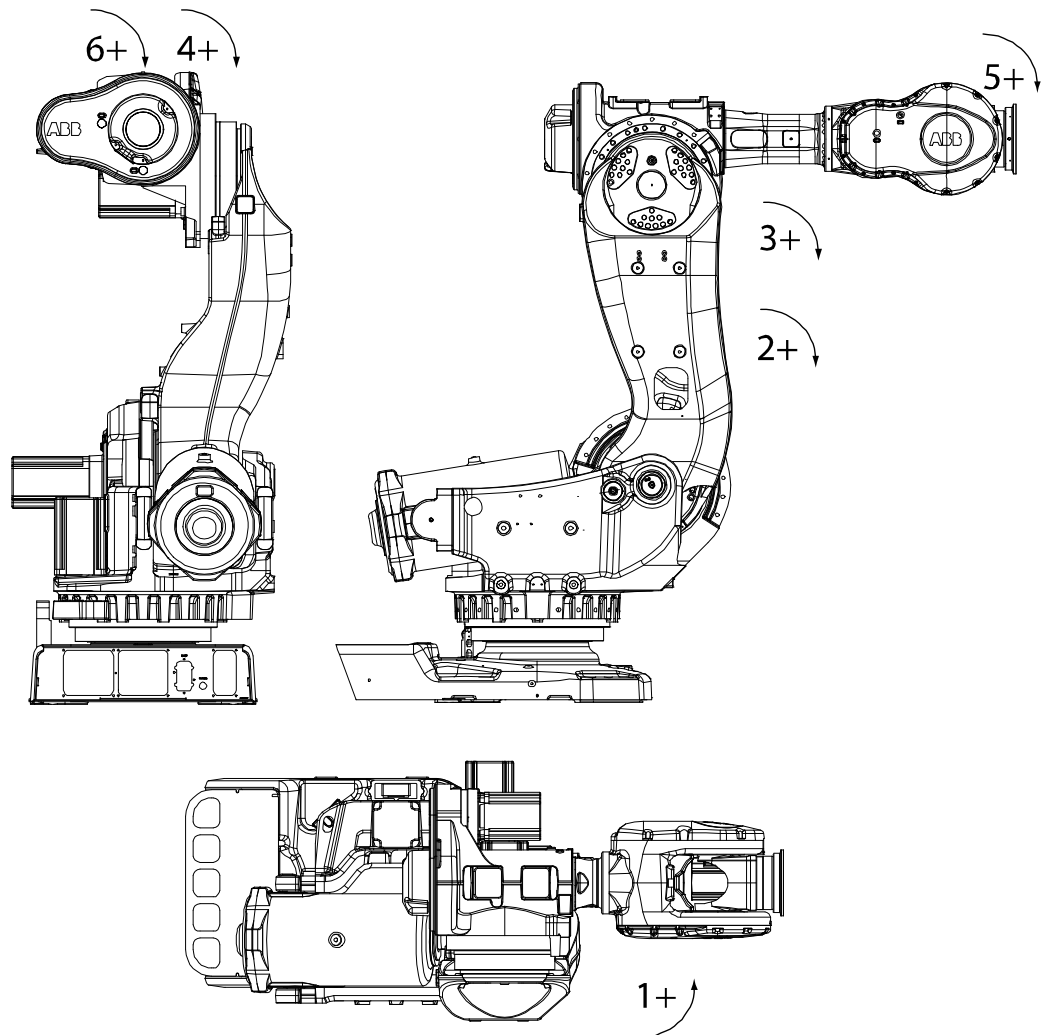

xx020000089

## 5.3 Updating revolution counters

### 5.3.1 Updating revolution counters on IRC5 robots

#### Introduction

This section describes how to do a rough calibration of each manipulator axis by updating the revolution counter for each axis, using the FlexPendant.

#### Coupled axes

When updating the revolution counters for a coupled axis, also the axis it is coupled to needs to be at its synchronization position for the update to be correct; i.e. axis 4 needs to be in synchronization position when updating axis 5 and 6.

With reversed coupled joints, the relationship is the opposite, i.e. axis 4 needs to be in synchronization position to update axis 3.

Coupled axes	IRB 140	IRB 1410	IRB 1520	IRB 1600	IRB 1600ID	IRB 1660ID	IRB 910 SC	IRB 2400	IRB 2600	IRB 2600ID	IRB 4400	IRB 4450S	IRB 4600
Axis 4, 5, 6	x			x				x	x		x	x	x
Axis 5, 6		x	x		x	x				x			
Axis 4, 3							x						

#### Step 1 - Manually running the manipulator to the synchronization position

Use this procedure to manually run the manipulator to the synchronization position.

	Action	Note
1	Select axis-by-axis motion mode.	
2	Jog the manipulator to align the synchronization marks.	See <a href="#">Synchronization marks and synchronization position for axes on page 358</a> .
3	When all axes are positioned, update the revolution counter.	<a href="#">Step 2 - Updating the revolution counter with the FlexPendant on page 362</a> .

#### Correct calibration position of axis 4 and 6

When jogging the manipulator to synchronization position, it is extremely important to make sure that axes 4 and 6 of the following mentioned manipulators are positioned correctly. The axes can be calibrated at the wrong turn, resulting in an incorrect manipulator calibration.

Make sure the axes are positioned according to the correct calibration values, not only according to the synchronization marks. The correct values are found on a label, located either on the lower arm, underneath the flange plate on the base or on the frame.

*Continues on next page*

## 5 Calibration

### 5.3.1 Updating revolution counters on IRC5 robots

*Continued*

At delivery the manipulator is in the correct position. Do NOT rotate axis 4 or 6 at power up before the revolution counters are updated.

If one of the following mentioned axes are rotated one or more turns from its calibration position before updating the revolution counter, the correct calibration position will be lost due to non-integer gear ratio. This affects the following manipulators:

Manipulator variant	Axis 4	Axis 6
IRB 4600	No	No

If the synchronization marks seem to be wrong (even if the motor calibration data is correct), try to rotate the axis one turn, update the revolution counter and check the synchronization marks again (try both directions, if needed).

#### Step 2 - Updating the revolution counter with the FlexPendant

Use this procedure to update the revolution counter with the FlexPendant (IRC5).

Action
1 On the <b>ABB</b> menu, tap <b>Calibration</b> .

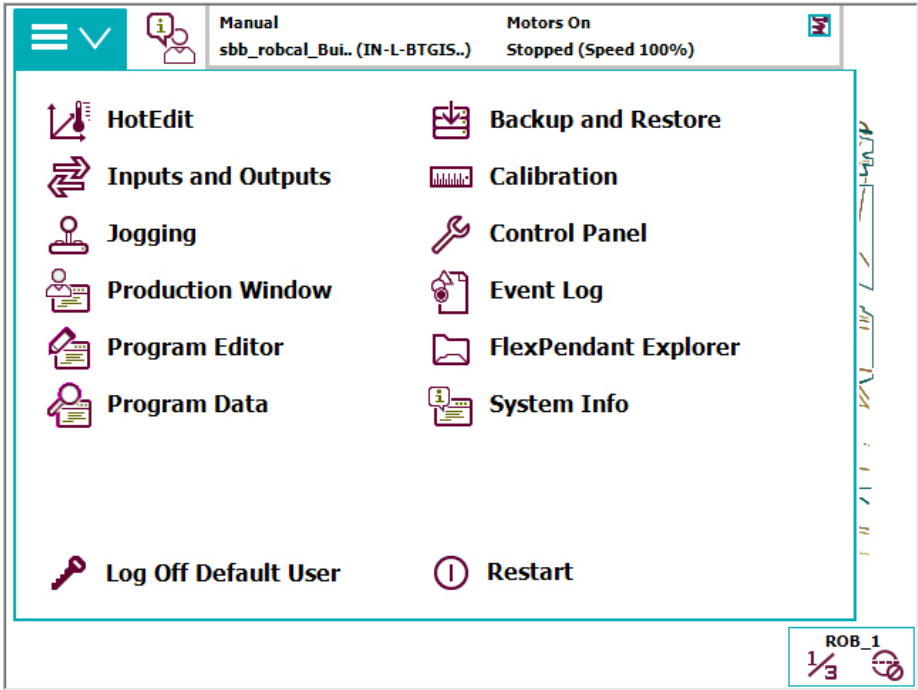

The screenshot shows the ABB FlexPendant menu interface. At the top, there is a status bar with 'Manual sbb\_robcal\_Bui.. (IN-L-BTGIS..)' and 'Motors On Stopped (Speed 100%)'. The main menu contains several options: HotEdit, Backup and Restore, Inputs and Outputs, Calibration, Jogging, Control Panel, Production Window, Event Log, Program Editor, FlexPendant Explorer, Program Data, System Info, Log Off Default User, and Restart. The 'Calibration' option is highlighted with a red box. At the bottom right, there is a 'ROB\_1' indicator with a speed limit icon (1/3) and a stop icon. The ID 'xx1500000942' is visible at the bottom left of the screenshot.

*Continues on next page*

**Action**

2 All mechanical units connected to the system are shown with their calibration status. Tap the mechanical unit in question.

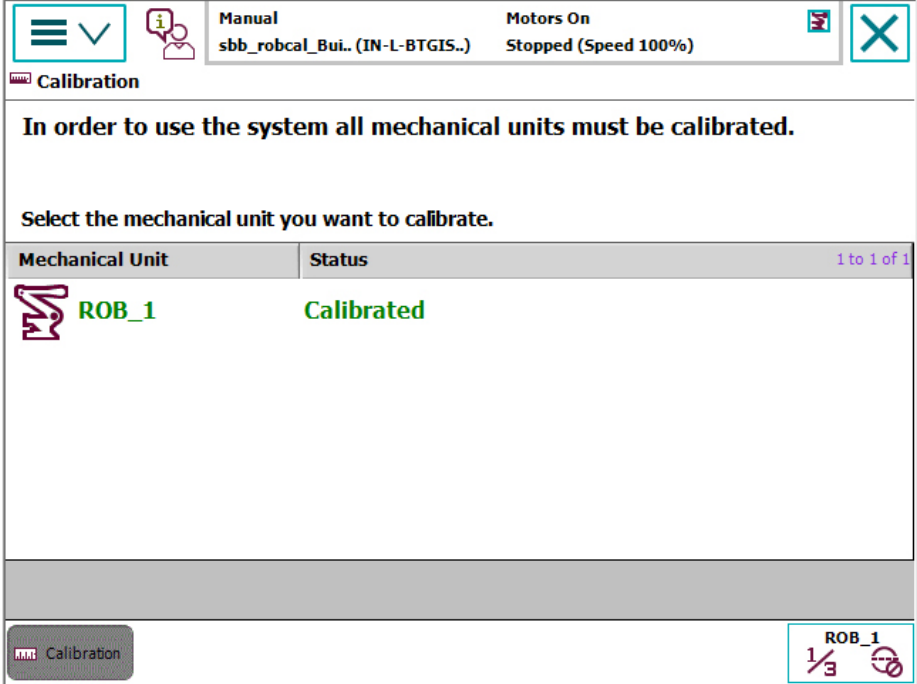

Manual sbb\_robcal\_Bui.. (IN-L-BTGIS..) Motors On Stopped (Speed 100%)

Calibration

In order to use the system all mechanical units must be calibrated.

Select the mechanical unit you want to calibrate.

Mechanical Unit	Status
 ROB_1	Calibrated

xx1500000943

3 This step is valid for RobotWare 6.02 and later. Calibration method used at factory for each axis is shown, as well as calibration method used during last field calibration. Tap Manual Method (Advanced).

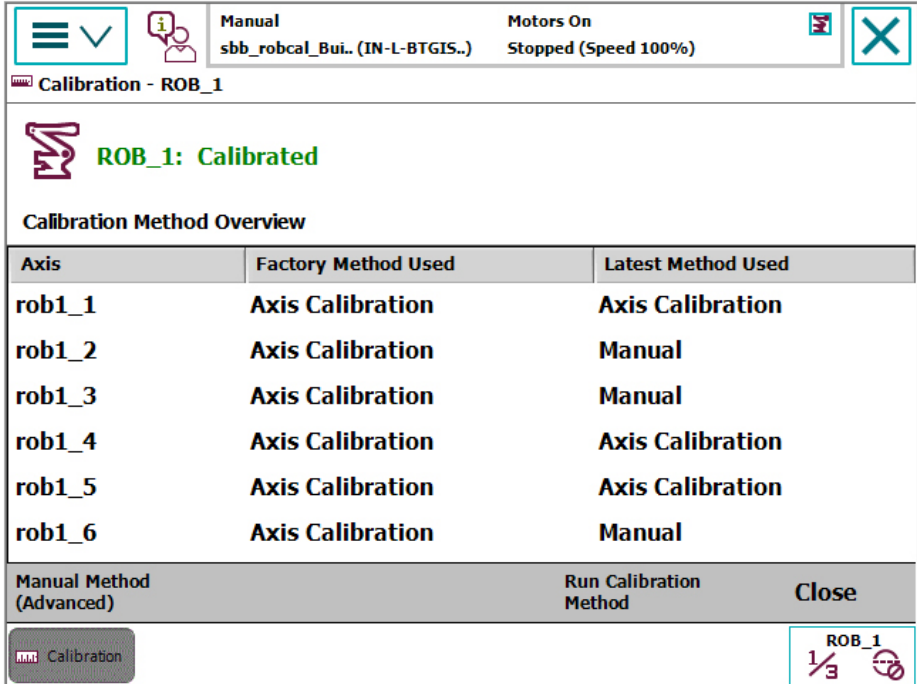

Manual sbb\_robcal\_Bui.. (IN-L-BTGIS..) Motors On Stopped (Speed 100%)

Calibration - ROB\_1

 ROB\_1: Calibrated

Calibration Method Overview

Axis	Factory Method Used	Latest Method Used
rob1_1	Axis Calibration	Axis Calibration
rob1_2	Axis Calibration	Manual
rob1_3	Axis Calibration	Manual
rob1_4	Axis Calibration	Axis Calibration
rob1_5	Axis Calibration	Axis Calibration
rob1_6	Axis Calibration	Manual

Manual Method (Advanced) Run Calibration Method Close

Calibration



xx1500000944

Continues on next page

## 5 Calibration

### 5.3.1 Updating revolution counters on IRC5 robots

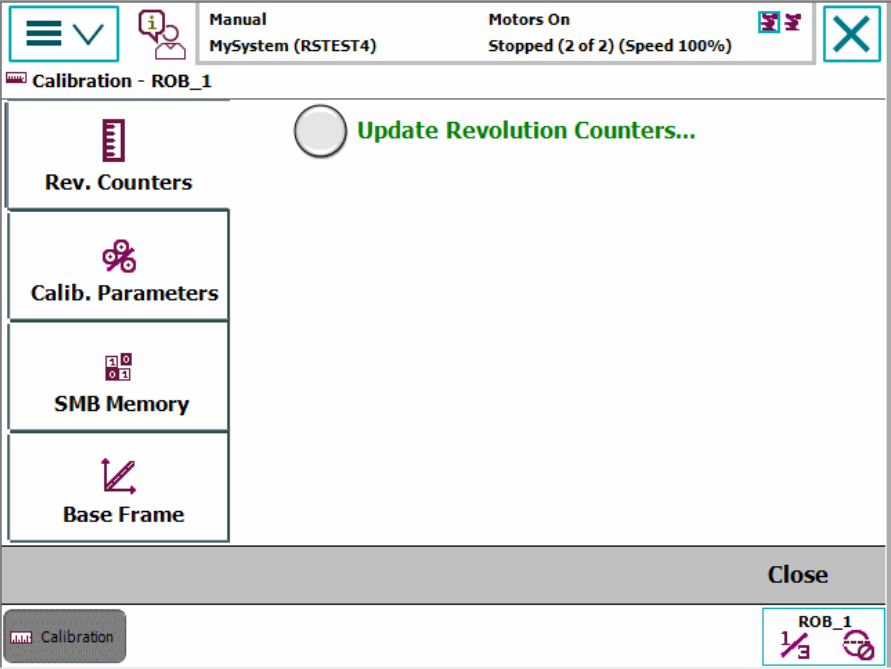
Continued

Action	
4	<p>A screen is displayed, tap <b>Rev. Counters</b>.</p>  <p>en040000771</p>
5	<p>Tap <b>Update Revolution Counters...</b></p> <p>A dialog box is displayed, warning that updating the revolution counters may change programmed robot positions:</p> <ul style="list-style-type: none"><li>• Tap <b>Yes</b> to update the revolution counters.</li><li>• Tap <b>No</b> to cancel updating the revolution counters.</li></ul> <p>Tapping <b>Yes</b> displays the axis selection window.</p>
6	<p>Select the axis to have its revolution counter updated by:</p> <ul style="list-style-type: none"><li>• Ticking in the box to the left</li><li>• Tapping <b>Select all</b> to update all axes.</li></ul> <p>Then tap <b>Update</b>.</p>
7	<p>A dialog box is displayed, warning that the updating operation cannot be undone:</p> <ul style="list-style-type: none"><li>• Tap <b>Update</b> to proceed with updating the revolution counters.</li><li>• Tap <b>Cancel</b> to cancel updating the revolution counters.</li></ul> <p>Tapping <b>Update</b> updates the selected revolution counters and removes the tick from the list of axes.</p>
8	<p> <b>CAUTION</b></p> <p>If a revolution counter is incorrectly updated, it will cause incorrect manipulator positioning, which in turn may cause damage or injury!</p> <p>Check the synchronization position very carefully after each update. See <a href="#">Checking the synchronization position on page 385</a>.</p>



## 5.3.2 Updating revolution counters on OmniCore robots

### Introduction

This section describes how to do a rough calibration of each manipulator axis by updating the revolution counter for each axis, using the FlexPendant.



### Step 1 - Manually running the manipulator to the synchronization position

Use this procedure to manually run the manipulator to the synchronization position.

	Action	Note
1	Select axis-by-axis motion mode.	
2	Jog the manipulator to align the synchronization marks.	See <a href="#">Synchronization marks and synchronization position for axes on page 358</a> .
3	When all axes are positioned, update the revolution counter.	<a href="#">Step 2 - Updating the revolution counter with the FlexPendant on page 365</a> .

### Step 2 - Updating the revolution counter with the FlexPendant

Use this procedure to update the revolution counter with the FlexPendant (OmniCore).

	Action
1	On the start screen, tap <b>Calibrate</b> .
2	Select <b>Calibration</b> from the menu. The <b>Mechanical Units</b> page displays a list of available mechanical units.  <b>Note</b> This step is required only if you are not already in the <b>Mechanical Unit</b> page when you open <b>Calibrate</b> .  <b>Note</b> The <b>Mechanical Unit</b> page is displayed only if there are more than one mechanical unit available. Otherwise, the calibration summary page for the available mechanical unit is displayed.
3	Select the mechanical unit for which revolution counter need to be updated.
4	The calibration summary page for the selected mechanical unit is displayed. Calibration method used at factory for each axis is shown, as well as calibration method used during last field calibration.
5	Tap <b>Calibration Methods</b> on the right pane. The calibration options are displayed.
6	Tap <b>Revolution Counters</b> .
7	In the <b>Selection</b> column select the axes for which revolution counters need to be updated.
8	Tap <b>Update</b> . A dialog box is displayed, warning that the updating operation cannot be undone: <ul style="list-style-type: none"> <li>• Tap <b>Update</b> to proceed with updating the revolution counters.</li> <li>• Tap <b>Cancel</b> to cancel updating the revolution counters.</li> </ul> Tapping <b>Update</b> and a confirmation window is displayed.

*Continues on next page*

## 5 Calibration

---

### 5.3.2 Updating revolution counters on OmniCore robots

*Continued*

Action	
9	Tap OK. The revolution counter for the selected axes is updated.
10	 <b>CAUTION</b> If a revolution counter is incorrectly updated, it will cause incorrect manipulator positioning, which in turn may cause damage or injury! Check the synchronization position very carefully after each update. See <a href="#">Checking the synchronization position on page 385</a> .

## 5.4 Calibrating with Axis Calibration method

### 5.4.1 Description of Axis Calibration

#### Instructions for Axis Calibration procedure given on the FlexPendant

The actual instructions of how to perform the calibration procedure and what to do at each step is given on the FlexPendant. You will be guided through the calibration procedure, step by step.

This manual contains a brief description of the method, additional information to the information given on the FlexPendant, article number for the tools and images of where to fit the calibration tools on the robot.

#### Overview of the Axis Calibration procedure

The Axis Calibration procedure applies to all axes, and is performed on one axis at the time. The robot axes are both manually and automatically moved into position, as instructed on the FlexPendant.

A fixed calibration pin/bushing is installed on each robot axis at delivery.

The Axis Calibration procedure described roughly:

- 1 A removable calibration tool is inserted by the operator into a calibration bushing on the axis chosen for calibration, according to instructions on the FlexPendant.



#### WARNING

Calibrating the robot with Axis Calibration requires special calibration tools from ABB. Using other pins in the calibration bushings may cause severe damage to the robot and/or personnel.



#### WARNING

The calibration tool must be fully inserted into the calibration bushing, until the steel spring ring snaps into place.

- 2 During the calibration procedure, RobotWare moves the robot axis chosen for calibration so that the calibration tools get into contact. RobotWare records values of the axis position and repeats the coming-in-contact procedure several times to get an exact value of the axis position.



#### WARNING

Risk of pinching! The contact force for large robots can be up to 150 kg. Keep a safe distance to the robot.

- 3 The axis position is stored in RobotWare with an active choice from the operator.

*Continues on next page*

## 5 Calibration

---

### 5.4.1 Description of Axis Calibration

*Continued*

---

#### Routines in the calibration procedure

The following routines are available in the Axis Calibration procedure, given at the beginning of the procedure on the FlexPendant.

##### Fine calibration routine

Choose this routine to calibrate the robot when there are no tools, process cabling or equipment fitted to the robot.

##### Reference calibration routine

Choose this routine to create reference values and to calibrate the robot when the robot is dressed with tools, process cabling or other equipment.

Also choose this routine if the robot is suspended.



#### Note

When calibrating the robot with the reference calibration routine, the robot must be dressed with the same tools, process cabling and any other equipment as when the reference values were created.

If calibrating the robot with reference calibration there must be reference values created before repair is made to the robot, if values are not already available. Creating new values requires possibility to move the robot. The reference values contain positions of all axes, torque of axes and technical data about the tool installed. A benefit with reference calibration is that the current state of the robot is stored and not the state when the robot left the ABB factory. The reference value will be named according to tool name, date etc.

Follow the instructions given in the reference calibration routine on the FlexPendant to create reference values.

When reference calibration is performed, the robot is restored to the status given by the reference values.

##### Update revolution counters

Choose this routine to make a rough calibration of each manipulator axis by updating the revolution counter for each axis, using the FlexPendant.

##### Validation

In the mentioned routines, it is also possible to validate the calibration data.

---

#### Position of robot axes

The robot axes should be positioned close to 0 degrees before commencing the calibration program. The axis chosen for calibration is then automatically run by the calibration program to its exact calibration position during the calibration procedure.

It is possible to position some of the other axes in positions different from 0 degrees. Information about which axes are allowed to be jogged is given on the FlexPendant.

*Continues on next page*

These axes are marked with **Unrestricted** in the FlexPendant window. Also the following table shows the dependencies between the axes.

Requirements for axis positioning during calibration

Required position of axis	Axis to calibrate					
	Axis 1	Axis 2	Axis 3	Axis 4	Axis 5	Axis 6
Axis 1	-	*	*	*	*	*
Axis 2	0	-	0	*	*	*
Axis 3	0	0	-	*	*	*
Axis 4	*	*	*	-	0	0
Axis 5	*	*	*	*	-	0
Axis 6	*	*	*	*	*	-

-	Axis to be calibrated
*	Unrestricted. Axis is allowed to be jogged to other position than 0 degrees.
0	Axis must be put in position 0 degrees.

#### System containing SafeMove

SafeMove will lose its synchronization to the controller if a new calibration is done. New calibration values have to be downloaded to SafeMove, and a new SafeMove calibration has to be done. Make sure that the user rights admit to change the safety settings and to synchronize SafeMove.

For robots with EPS, the same applies as for SafeMove.

#### How to calibrate a suspended robot

The IRB 4600 Foundry Prime is fine calibrated floor standing in factory, prior to shipping.

To calibrate a suspended robot, reference calibration must be used. Reference values for a suspended robot must be created with the robot mounted at its working position, not standing on a floor.

To calibrate a suspended robot with the fine calibration routine, the robot must first be taken down and then be mounted standing on the floor.

## 5 Calibration

### 5.4.2 Calibration tools for Axis Calibration

#### 5.4.2 Calibration tools for Axis Calibration

##### Calibration tool set

The calibration tools used for Axis Calibration are designed to meet requirements for calibration performance, durability and safety in case of accidental damage.

The calibration tool will eventually break from fatigue after longer period of use and then needs to be replaced. There is no risk for bad calibrations as long as the calibration tool is in one piece.



##### WARNING

Calibrating the robot with Axis Calibration requires special calibration tools from ABB. Using other pins in the calibration bushings may cause severe damage to the robot and/or personnel.

Equipment, etc.	Article number	Note
Calibration tool box, Axis Calibration	3HAC074119-001	Delivered as a set of calibration tools. Required if Axis Calibration is the valid calibration method for the robot. Contains a removal tool for removing special protection plugs on the turning disk.

##### Examining the calibration tool

##### Check prior to usage

Before using the calibration tool, make sure that the tube insert, the plastic protection and the steel spring ring are present.



##### WARNING

If any part is missing or damaged, the tool must be replaced immediately.

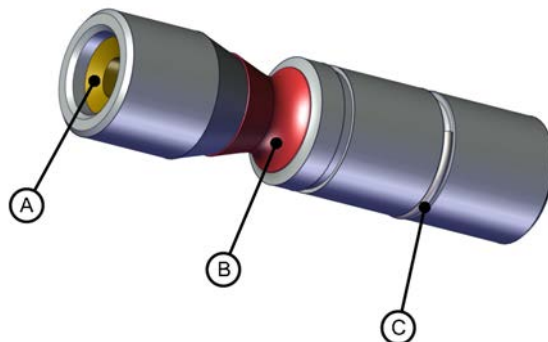

xx1500001914

A	Tube insert
B	Plastic protection
C	Steel spring ring

*Continues on next page*

#### Periodic check of the calibration tool

If including the calibration tool in a local periodic check system, the following measures should be checked.

- Outer diameter within  $\varnothing 12g4$  mm,  $\varnothing 8g4$  mm or  $\varnothing 6g5$  mm (depending on calibration tool size).
- Straightness within 0.005 mm.

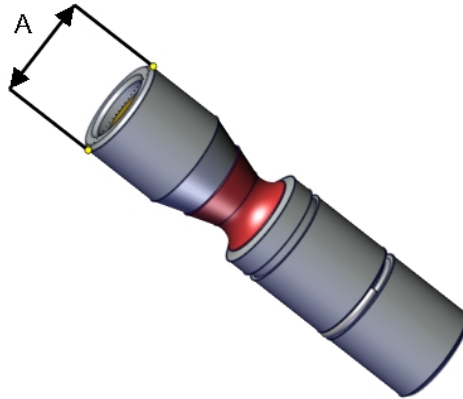

xx150000951

A	Outer diameter
---	----------------

## 5 Calibration

### 5.4.3 Installation locations for the calibration tools

### 5.4.3 Installation locations for the calibration tools

#### Location of fixed calibration items

This section shows how the robot is equipped with items for installation of calibration tools for Axis Calibration (fixed calibration pins and/or bushings). Installed calibration tools are not shown.

A fixed calibration pin and a bushing for the movable calibration tool are located on each axis as follows.

If there is not enough space on an axis to install a fixed calibration pin, the axis is equipped with two bushings instead, for installation of two calibration tools when calibration is carried out. This is shown in the figure.

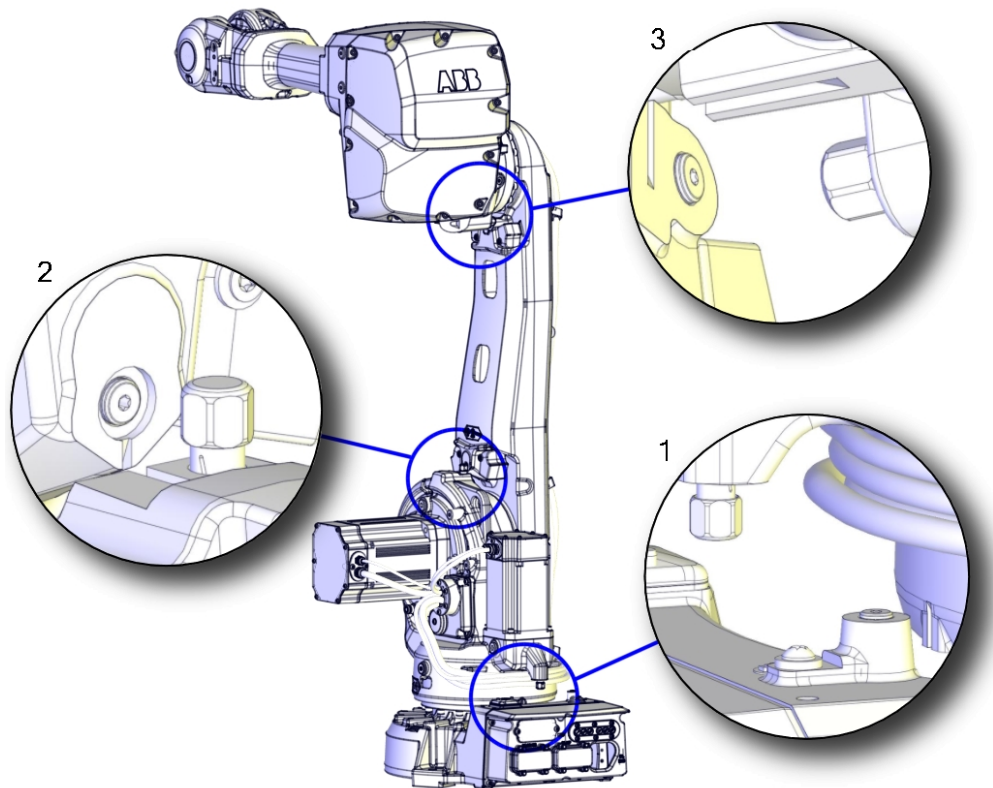

xx160000641

*Continues on next page*



*Continued*

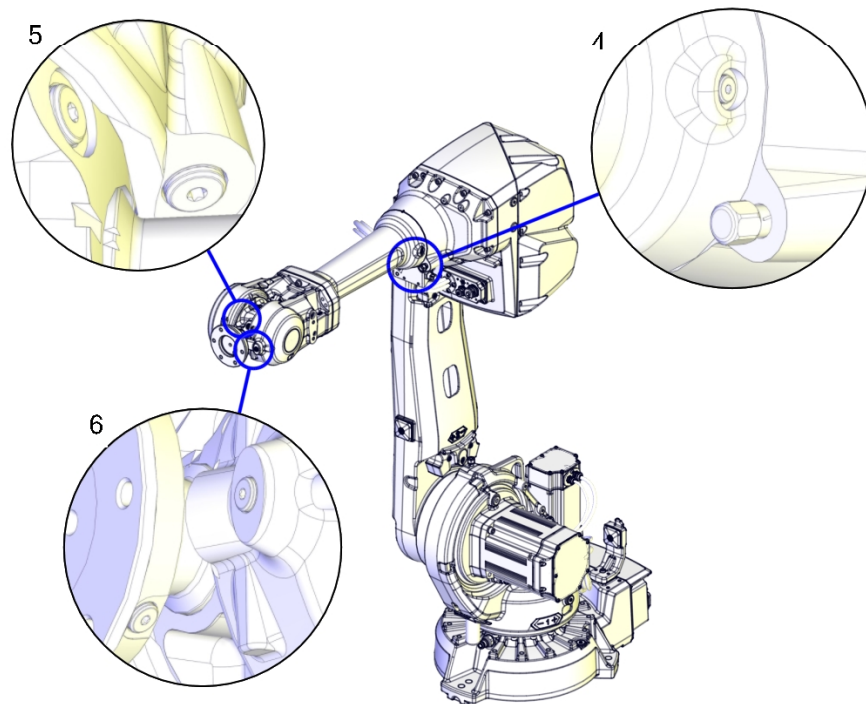

xx160000642

#### Spare parts

When calibration is not being performed, a protective cover and an o-ring should always be installed on the fixed calibration pin as well as a protective plug, included a sealing, in the bushing. Replace damaged parts with new.

Spare part	Article number	Note
Protection cover and plug set	3HAC060730-001 (protection type Foundry Prime)	Contains replacement calibration pin covers and protective plugs for the bushing.
Protective plug on turning disc	3HAC057511-001	Only on IRB 4600 - 20/2.50. Replace if damaged or missing.

## 5 Calibration

### 5.4.4 Axis Calibration - Running the calibration procedure

#### 5.4.4 Axis Calibration - Running the calibration procedure

##### Required tools

The calibration tools used for Axis Calibration are designed to meet requirements for calibration performance, durability and safety in case of accidental damage.



##### WARNING

Calibrating the robot with Axis Calibration requires special calibration tools from ABB. Using other pins in the calibration holes may cause severe damage to the robot and/or personnel.

Equipment, etc.	Article number	Note
Calibration tool box, Axis Calibration	3HAC074119-001	Delivered as a set of calibration tools. Required if Axis Calibration is the valid calibration method for the robot. Contains a removal tool for removing special protection plugs on the turning disk.

##### Required consumables

Consumable	Article number	Note
Clean cloth	-	

##### Spare parts

Spare part	Article number	Note
Protection cover and plug set	3HAC060730-001 (protection type Foundry Prime)	Contains replacement calibration pin covers and protective plugs for the bushing.
Protective plug on turning disc	3HAC057511-001	Only on IRB 4600 - 20/2.50. Replace if damaged or missing.

##### Overview of the calibration procedure on the FlexPendant

The actual instructions of how to perform the calibration procedure and what to do at each step is given on the FlexPendant. You will be guided through the calibration procedure, step by step.

Use the following list to learn about the calibration procedure before running the RobotWare program on the FlexPendant. It gives you a brief overview of the calibration procedure.

After the calibration method has been started on the FlexPendant, the following sequence will be run.

- 1 Choose calibration routine. The routines are described in [Routines in the calibration procedure on page 368](#).
- 2 Choose which axis/axes to calibrate.
- 3 The robot moves to synchronization position.
- 4 Validate the synchronization marks.

*Continues on next page*

### 5.4.4 Axis Calibration - Running the calibration procedure *Continued*

- 5 The robot moves to preparation position.
- 6 Remove the protective cover from the fixed pin and the protection plug from the bushing, if any, and install the calibration tool.

Use the removal tool included in the calibration tool box to remove the special protection plug(s) on the turning disc.

IRB 4600 - 20/2.50:

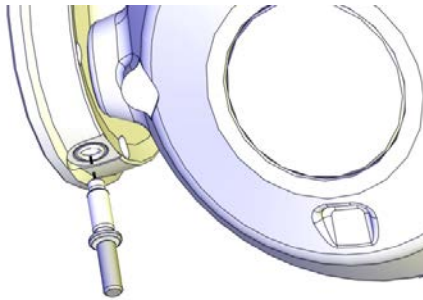

xx1700000905



When calibrating axis 6, push in the calibration tool into the turning disc until the snap ring engages, no further.

- 7 The robot performs a measurement sequence by rotating the axis back and forth.
- 8 Remove the calibration tool and reinstall the protective cover on the fixed pin and the protection plug in the bushing, if any.  
Refit the protection plug(s) to the turning disc, push until the steel spring ring snaps into place.
- 9 The robot moves to verify that the calibration tool is removed.
- 10 Choose whether to save the calibration data or not.

Calibration of the robot is not finished until the calibration data is saved, as last step of the calibration procedure.

#### Preparation prior to calibration

The calibration procedure is described in the FlexPendant while conducting it.

	Action	Note
1	 <b>DANGER</b> While conducting the calibration, the robot needs to be connected to power. Make sure that the robot's working area is empty, as the robot can make unpredictable movements.	
2	Wipe the calibration tool clean.  <b>Note</b> The calibration method is exact. Dust, dirt or color flakes will affect the calibration value.	Use a clean cloth.

*Continues on next page*

## 5 Calibration

### 5.4.4 Axis Calibration - Running the calibration procedure

*Continued*

	Action	Note
3	Check if the standard calibration data for axes 4, 5 or 6 are updated with wrist optimization. This is shown in the calibration overview/summary window on the FlexPendant.	If the data is optimized, the calibration routine <b>Wrist Optimization</b> must be re-run after standard calibration.  See <a href="#">Calibrating with Wrist Optimization method on page 382</a> .

#### Starting the calibration procedure

Use this procedure to start the Axis Calibration routine on the FlexPendant.

	Action	Note
1	Tap the calibration icon and enter the calibration main page.	
2	All mechanical units connected to the system are shown with their calibration status. Tap the mechanical unit in question.   <b>Note</b> For RobotWare 7, the mechanical unit page is displayed only if there is more than one mechanical unit available.	
3	The calibration method used at ABB factory for each axis is shown, as well as calibration method used for the robot during last field calibration.	The FlexPendant will give all information needed to proceed with Axis Calibration.
4	<b>Valid for RobotWare 6</b> Tap <b>Call Calibration Method</b> . The software will automatically call for the procedure for the valid calibration method. If not, tap <b>Call Routine</b> and then tap <b>Axis calibration</b> .	
5	<b>Valid for RobotWare 7</b> Tap <b>Calibration Methods</b> on the right pane and then tap <b>Calibration</b> . The software will automatically call for the procedure for the valid calibration method.	
6	Follow the instructions given on the FlexPendant.	A brief overview of the sequence that will be run on the FlexPendant is given in <a href="#">Overview of the calibration procedure on the FlexPendant on page 374</a> .

#### Restarting an interrupted calibration procedure

If the Axis Calibration procedure is interrupted before the calibration is finished, the RobotWare program needs to be started again. Use this procedure to take required action.

Situation	Action
The three-position enabling device on the FlexPendant has been released during robot movement.	Press and hold the three-position enabling device and press <b>Play</b> .

*Continues on next page*

5.4.4 Axis Calibration - Running the calibration procedure  
Continued

Situation	Action
The RobotWare program is terminated with PP to Main.	Remove the calibration tool, if it is installed, and restart the calibration procedure from the beginning. See <i>Starting the calibration procedure</i> .  If the calibration tool is in contact the robot axis needs to be jogged in order to release the calibration tool. Jogging the axis in wrong direction will cause the calibration tool to break. Directions of axis movement is shown in <a href="#">Calibration movement directions for all axes on page 360</a>

**Axis Calibration with SafeMove option**

To be able to run Axis Calibration, SafeMove needs to be unsynchronized. The Axis Calibration routine recognizes if the robot is equipped with SafeMove and will force SafeMove to unsynchronize automatically.

However, SafeMove may generate other warning messages anytime during the Axis Calibration routine. When a warning message is displayed, tap **Acknowledge** to confirm the unsynchronized state and continue Axis Calibration procedure.



**CAUTION**

SafeMove must be synchronized after the calibration is completed.

**After calibration**

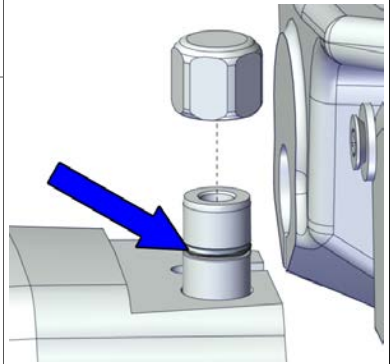
	Action	Note
1	Check the o-ring on the fixed calibration pin. Replace if damaged or missing.	 <p>xx1600002102</p> <p>Protection cover and plug set: . 3HAC060730-001 (protection type Foundry Prime)</p>
2	Reinstall the protective cover on the fixed calibration pin on each axis, directly after the axis has been calibrated.  Replace the cover with new spare part, if missing or damaged.	

Continues on next page

## 5 Calibration

### 5.4.4 Axis Calibration - Running the calibration procedure

Continued

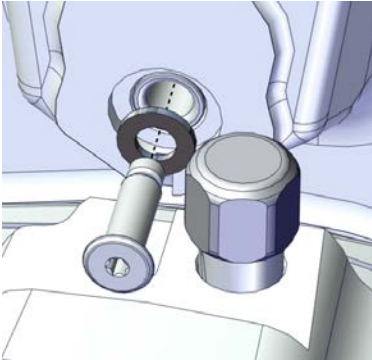
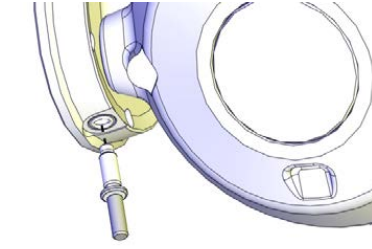
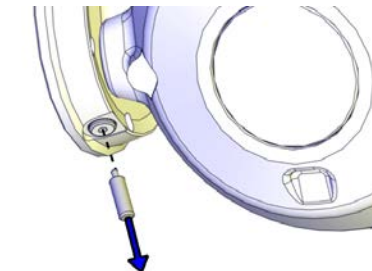
	Action	Note
3	<p>Reinstall the protective plug and sealing in the bushing on each axis, directly after the axis has been calibrated. Ensure that the sealing is not damaged.</p> <p>Tighten the plug lightly so that the sealing washer is just about fastened between the plug and the bushing. Then tighten 1/4 turn more.</p> <p>Replace the plug and the sealing with new spare part, if missing or damaged.</p>	 <p>xx1600002103</p> <p>Protection cover and plug set: . 3HAC060730-001 (protection type Foundry Prime)</p>
4	<p>Refit the special protection plug to the turning disc using the tool included in the calibration tool box.</p>	<p>IRB 4600 - 20/2.50</p>  <p>xx1700000905</p>
5	<p>Remove the tool from the protection plug.</p>	<p>IRB 4600 - 20/2.50</p>  <p>xx1700000906</p>
6	<p>If the standard calibration data for axes 4, 5 or 6 should be updated with wrist optimization, run the calibration routine <b>Wrist Optimization</b>.</p>	<p>See <a href="#">Calibrating with Wrist Optimization method on page 382</a>.</p>

---

## 5.4.5 Reference calibration

---

### Brief introduction to Reference Calibration

Reference calibration is a faster method compared to Fine calibration, as it refers to a previously made calibration.

- 1 Create a backup of the current robot system.
- 2 Check that the active calibration offset values corresponds to the values on the silver label (on the lower arm or the base).
- 3 Jog the manipulator so that all axes are in zero position (ex use `MoveAbsJ` instruction). Check that all axis scales are aligned with calibration marks.
- 4 If the scales differ from calibration marks it might depend on wrong turns of the revolution counters. Make a marker line on the corresponding axis to be able to validate the result of the calibration. If more than one motor revolutions are wrong, the calibration will fail.
- 5 Use a verification position. This is especially recommended if all axes were not aligned with the synchronization marks (step 3). Reuse an existing position that is suitable and accurate so it can be used to validate the repair. Use a position where a deviation in axis calibration gives a big deviation in positioning. Note! Check the position after each repair in one axis.
- 6 Use Reference calibration to save reference values for all axes that is to be replaced. Make sure that the values are saved in RobotStudio or FTP program. The files are located in "Active system folder name/HOME/RefCalibFiles".
- 7 Perform the repair.
- 8 Make sure that the tooling and process equipment are the same as when creating the reference. Use Reference calibration to update the system with new calibration offset value for the repaired axis.
- 9 Check the position against the verification position (step 5).
- 10 Proceed with the repair of the next axis, if necessary, and repeat (step 8-9) for every axis.
- 11 (For system containing SafeMove or EPS) Download new calibration values to SafeMove. Use Visual SafeMove in RobotStudio.(For system containing SafeMove) Download new calibration values to SafeMove. Use Visual SafeMove in RobotStudio.
- 12 (For system containing SafeMove or EPS) Synchronize SafeMove to activate SafeMove.(For system containing SafeMove) Synchronize SafeMove to activate SafeMove.
- 13 Perform test run.
- 14 Update the label for resolver values with new calibration values.

### Manual tuning of calibration offset

Manual tuning of calibration offset is normally not needed, but can be useful in some situations. The requirement to do manual tuning is that there is a known accurate position, that worked accurately before the repair (step 5, see [Brief introduction to Reference Calibration on page 379](#)).

*Continues on next page*

## 5 Calibration

---

### 5.4.5 Reference calibration

*Continued*

Example "Adjust axis 4":

- 1 Create a backup.
- 2 Run the manipulator to the verification position. (The manipulator position is now deviating from the verification position.)
- 3 Read and note current axis 4 value in degrees (example: 96.3 degrees).
- 4 Manually jog, only axis 4, so that the manipulator is correctly positioned to the verification position.
- 5 Read and note current axis 4 value in degrees (example: 94.2 degrees).
- 6 Move the manipulator to its calibration position.
- 7 Calculate the angle difference (ie  $96.3 - 94.2 = 2.1$  degrees).
- 8 Manually jog axis 4 the calculated angle difference (-2.1). NOTE! The direction +/- shall be the same direction as the direction used when axis 4 was manually jogged to coincide with the verification process. In the example -2.1 degrees.
- 9 Make a new manual fine calibration of axis 4 with axis in -2.1 degrees position.
- 10 Check again against the verification position.
- 11 Repeat the manual tuning if needed.
- 12 Create a new reference if the intention is to use the reference in the future.



### 5.5 Calibrating with Calibration Pendulum method

---

#### Where to find information for Calibration Pendulum

Detailed instructions of how to perform Pendulum Calibration are given in the documentation enclosed with the calibration tools.

## 5 Calibration

### 5.6 Calibrating with Wrist Optimization method

### 5.6 Calibrating with Wrist Optimization method

#### When to run Wrist Optimization

Wrist Optimization routine is run to improve TCP reorientation performance.

Calibrating the robot with standard calibration method overwrites the optimized positions of axes 4, 5, 6. Re-run the Wrist Optimization routine after standard calibration to re-achieve the optimized positions of the wrist axes.

#### Overview of the calibration procedure on the FlexPendant

The actual instructions of how to perform the calibration procedure and what to do at each step is given on the FlexPendant. You will be guided through the calibration procedure, step by step.

Use the following list to learn about the calibration procedure before running the RobotWare program on the FlexPendant. It gives you a brief overview of the calibration procedure sequence.

After the calibration method has been called for on the FlexPendant, the following sequence will be run.

- 1 Choose calibration routine Wrist Optimization.
- 2 Modify targets for 4-point tool frame definition, in Wrist Optimization routine.



#### Tip

Select positions with large reorientations around the TCP. For best results, make sure that axis 4 and 5 have large movements.

- a Jog the robot to an appropriate position, A, for the first approach point.  
Use small increments to accurately position the tool tip as close to the reference point as possible.
- b Tap **Modify Position** to define the point.
- c Repeat for each approach point to be defined, positions B, C, and D.  
Jog away from the fixed world point to achieve the best result. Just changing the tool orientation will not give as good a result.

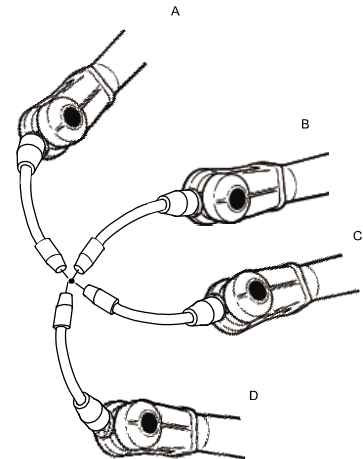

en0400000906

- 3 Improved calibration data to the wrist axes is identified and presented.
- 4 Optimized positions for the wrist axes are presented.

*Continues on next page*

- 5 The robot moves to the optimized positions for the wrist axes and automatically overwrites previous calibration data.



**WARNING**

Robot moves automatically when pressing **Calibrate**.

- 6 Wrist optimization is finished.
- 7 Redefine / verify TCP for all tools.

## 5 Calibration

---

### 5.7 Verifying the calibration

### 5.7 Verifying the calibration

---

#### Introduction

Always verify the results after calibrating *any* robot axis to verify that all calibration positions are correct.

---

#### Verifying the calibration

Use this procedure to verify the calibration result.

	Action	Note
1	Run the calibration home position program twice. Do not change the position of the robot axes after running the program!	See <a href="#">Checking the synchronization position on page 385</a> .
2	Adjust the <i>synchronization marks</i> when the calibration is done, if necessary.	This is detailed in section <a href="#">Synchronization marks and synchronization position for axes on page 358</a> .
3	Write down the values on a new label and stick it on top of the calibration label. The label is located on the lower arm.	

## 5.8 Checking the synchronization position

### Introduction

Check the synchronization position of the robot before beginning any programming of the robot system. This may be done:

- Using a `MoveAbsJ` instruction with argument zero on all axes.
- Using the **Jogging** window on the FlexPendant. Using the **Jog** window on the FlexPendant.

### Using a `MoveAbsJ` instruction

Use this procedure to create a program that runs all the robot axes to their synchronization position.

	Action	Note
1	On ABB menu tap <b>Program editor</b> .	
2	Create a new program.	
3	Use <b>MoveAbsJ</b> in the <b>Motion&amp;Proc</b> menu.	
4	Create the following program: <pre>MoveAbsJ [[0,0,0,0,0,0],           [9E9,9E9,9E9,9E9,9E9,9E9]]           \NoEOffs, v1000, fine, tool0</pre>	
5	Run the program in manual mode.	
6	Check that the synchronization marks for the axes align correctly. If they do not, update the revolution counters.	See <a href="#">Synchronization marks and synchronization position for axes on page 358</a> and <a href="#">Updating revolution counters on page 361</a> .

### Using the jogging window

Use this procedure to jog the robot to the synchronization position of all axes.

	Action	Note
1	On the <b>ABB</b> menu, tap <b>Jogging</b> .	
2	Tap <b>Motion mode</b> to select group of axes to jog.	
3	Tap to select the axis to jog, axis 1, 2, or 3.	
4	Manually run the robots axes to a position where the axis position value read on the FlexPendant, is equal to zero.	
5	Check that the synchronization marks for the axes align correctly. If they do not, update the revolution counters.	See <a href="#">Synchronization marks and synchronization position for axes on page 358</a> and <a href="#">Updating revolution counters on page 361</a> .

Continues on next page

## 5 Calibration

### 5.8 Checking the synchronization position

*Continued*

#### Using a MoveAbsJ instruction

Use this procedure to create a program that runs all the robot axes to their synchronization position.

	Action	Note
1	Tap Code.	
2	Create a new program.	
3	Use <b>MoveAbsJ</b> in the <b>Add Instruction</b> menu.	
4	Create the following program: <pre>MoveAbsJ [[0,0,0,0,0,0],           [9E9,9E9,9E9,9E9,9E9,9E9]] \NoEOfs, v1000, fine, tool0</pre>	
5	Run the program in manual mode.	
6	Check that the synchronization marks for the axes align correctly. If they do not, update the revolution counters.	See <a href="#">Synchronization marks and synchronization position for axes on page 358</a> and <a href="#">Updating revolution counters on page 361</a> .

#### Using the jogging window

Use this procedure to jog the robot to the synchronization position of all axes.

	Action	Note
1	Tap Jog.	
2	From the <b>Mechanical unit</b> list select a mechanical unit.	
3	From the <b>Motion mode</b> section, select an axis-set that need to be jogged. For example, to jog axis 2, select the axis set <b>Axis 1-3</b> .	
4	Follow the screen instruction on joystick movements to understand the direction of the axis that you want to move and move the joystick.	
5	Manually run the robots axes to a position where the axis position value read on the FlexPendant, is equal to zero.	
6	Check that the synchronization marks for the axes align correctly. If they do not, update the revolution counters.	See <a href="#">Synchronization marks and synchronization position for axes on page 358</a> and <a href="#">Updating revolution counters on page 361</a> .

# 6 Decommissioning

## 6.1 Introduction to decommissioning

### Introduction

This section contains information to consider when taking a product, robot or controller, out of operation.

It deals with how to handle potentially dangerous components and potentially hazardous materials.



#### Note

The decommissioning process shall be preceded by a risk assessment.

### General

All used grease/oils and dead batteries **must** be disposed of in accordance with the current legislation of the country in which the robot and the control unit are installed.

If the robot or the control unit is partially or completely disposed of, the various parts **must** be grouped together according to their nature (which is all iron together and all plastic together), and disposed of accordingly. These parts **must** also be disposed of in accordance with the current legislation of the country in which the robot and control unit are installed.

## 6 Decommissioning

### 6.2 Environmental information

## 6.2 Environmental information

### Introduction

ABB robots contain components in different materials. During decommissioning, all materials should be dismantled, recycled, or reused responsibly, according to the relevant laws and industrial standards. Robots or parts that can be reused or upcycled helps to reduce the usage of natural resources.

### Symbol

The following symbol indicates that the product must not be disposed of as common garbage. Handle each product according to local regulations for the respective content (see table below).

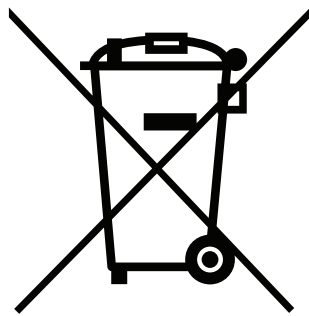

xx180000058

### Materials used in the product

The table specifies some of the materials in the product and their respective use throughout the product.

Dispose components properly according to local regulations to prevent health or environmental hazards.

Material	Example application
Aluminium	Covers, synchronization brackets
Batteries, Lithium	Serial measurement board
Cast iron/nodular iron	Base, lower arm, upper arm
Copper	Cables, motors
Neodymium	Brakes, motors
Nickel	Turning disc (foundry)
Oil, grease	Gearboxes
Plastic/rubber	Cables, connectors, drive belts, and so on.
Steel	Gears, screws, base frame, and so on.

*Continues on next page*



#### Oil and grease

Where possible, arrange for oil and grease to be recycled. Dispose of via an authorized person/contractor in accordance with local regulations. Do not dispose of oil and grease near lakes, ponds, ditches, down drains, or onto soil. Incineration must be carried out under controlled conditions in accordance with local regulations.

Also note that:

- Spills can form a film on water surfaces causing damage to organisms. Oxygen transfer could also be impaired.
- Spillage can penetrate the soil causing ground water contamination.

## 6 Decommissioning

---

### 6.3 Scrapping of robot

### 6.3 Scrapping of robot



#### Note

The decommissioning process shall be preceded by a risk assessment.

---

#### Important when scrapping the robot



#### DANGER

The risk assessment should consider hazards arising in the decommissioning, such as, but not limited to:

- Always remove all batteries. If a battery is exposed to heat, for example from a blow torch, it will explode.
- Always remove all oil/grease in gearboxes. If exposed to heat, for example from a blow torch, the oil/grease will catch fire.
- When motors are removed from the robot, the robot will collapse if it is not properly supported before the motor is removed.
- A used robot does not have the same performance as on delivery. Springs, brakes, bearings, and other parts might be worn or broken.

# 7 Reference information

## 7.1 Introduction

---

### General

This chapter includes general information, complementing the more specific information in the different procedures in the manual.

## 7 Reference information

### 7.2 Applicable standards

### 7.2 Applicable standards

#### General

The product is compliant with ISO 10218-1:2011, *Robots for industrial environments - Safety requirements - Part 1 Robots*, and applicable parts in the normative references, as referred to from ISO 10218-1:2011. In case of deviation from ISO 10218-1:2011, these are listed in the declaration of incorporation. The declaration of incorporation is part of the delivery.

#### Robot standards

Standard	Description
ISO 9283	Manipulating industrial robots – Performance criteria and related test methods
ISO 9787	Robots and robotic devices – Coordinate systems and motion nomenclatures
ISO 9946	Manipulating industrial robots – Presentation of characteristics

#### Other standards used in design

Standard	Description
IEC 60204	Safety of machinery - Electrical equipment of machines - Part 1: General requirements, normative reference from ISO 10218-1
IEC 61000-6-2	Electromagnetic compatibility (EMC) – Part 6-2: Generic standards – Immunity standard for industrial environments
IEC 61000-6-4	Electromagnetic compatibility (EMC) – Part 6-4: Generic standards – Emission standard for industrial environments
ISO 13849-1:2006	Safety of machinery - Safety related parts of control systems - Part 1: General principles for design, normative reference from ISO 10218-1

#### Region specific standards and regulations

Standard	Description
ANSI/RIA R15.06	Safety requirements for industrial robots and robot systems
ANSI/UL 1740	Safety standard for robots and robotic equipment
CAN/CSA Z 434-03	Industrial robots and robot Systems - General safety requirements
EN ISO 10218-1	Robots and robotic devices — Safety requirements for industrial robots — Part 1: Robots

## 7.3 Unit conversion

### Converter table

Use the following table to convert units used in this manual.

Quantity	Units		
Length	1 m	3.28 ft.	39.37 in
Weight	1 kg	2.21 lb.	
Weight	1 g	0.035 ounces	
Pressure	1 bar	100 kPa	14.5 psi
Force	1 N	0.225 lbf	
Moment	1 Nm	0.738 lbf-ft	
Volume	1 L	0.264 US gal	

## 7 Reference information

---

### 7.4 Screw joints

### 7.4 Screw joints

---

#### General

This section describes how to tighten the various types of screw joints on ABB robots.

The instructions and torque values are valid for screw joints comprised of metallic materials and do *not* apply to soft or brittle materials.

---

#### UNBRAKO screws

UNBRAKO is a special type of screw recommended by ABB for certain screw joints. It features special surface treatment (Gleitmo as described below) and is extremely resistant to fatigue.

Whenever used, this is specified in the instructions, and in such cases, *no other type of replacement screw* is allowed. Using other types of screws will void any warranty and may potentially cause serious damage or injury.

---

#### Gleitmo treated screws

Gleitmo is a special surface treatment to reduce the friction when tightening the screw joint. It is recommended by ABB for M6-M20 screw joints. Screws treated with Gleitmo may be reused 3-4 times before the coating disappears. After this the screw must be discarded and replaced with a new one.

When handling screws treated with Gleitmo, protective gloves of nitrile rubber type should be used.

Generally, screws are lubricated with *Gleitmo 603* mixed with *Geomet 500* or *Geomet 702* in proportion 1:3. *Geomet* thickness varies according to screw dimensions, refer to the following.

Dimension	Lubricant	Geomet thickness
M6-M20 (any length except M20x60)	<i>Gleitmo 603 + Geomet 500</i>	3-5 µm
M6-M20 (any length except M20x60)	<i>Gleitmo 603 + Geomet 720</i>	3-5 µm
M20x60	<i>Gleitmo 603 + Geomet 500</i>	8-12 µm
M20x60	<i>Gleitmo 603 + Geomet 720</i>	6-10 µm

---

#### Screws lubricated in other ways

Screws lubricated with Molykote 1000 or Molykote P1900 should *only* be used when specified in the repair, maintenance or installation procedure descriptions.

In such cases, proceed as follows:

- 1 Apply lubricant to the screw thread.
- 2 Apply lubricant between the plain washer and screw head.
- 3 Screw dimensions of M8 or larger must be tightened with a torque wrench. Screw dimensions of M6 or smaller may be tightened without a torque wrench *if* this is done by trained and qualified personnel.

*Continues on next page*

Lubricant	Article number
Molykote 1000 (molybdenum disulphide grease)	3HAC042472-001
Molykote P1900 (molybdenum disulphide grease)	3HAC070875-001

### Tightening torque

Before tightening any screw, note the following:

- Determine whether a **standard** tightening torque or **special** torque is to be applied. The **standard torques** are specified in the following tables. Any **special torques** are specified in the repair, maintenance or installation procedure descriptions. **Any special torque specified overrides the standard torque!**
- Use the *correct tightening torque* for each type of screw joint.
- Only use *correctly calibrated* torque keys.
- *Always tighten the joint by hand*, and never use pneumatic tools.
- Use the *correct tightening technique*, that is *do not* jerk. Tighten the screw in a slow, flowing motion.
- Maximum allowed total deviation from the specified value is **10%!**

#### Oil-lubricated screws with slotted or cross-recess head screws

The following table specifies the recommended standard tightening torque for *oil-lubricated screws with slotted or cross-recess head screws*.



#### Note

A special torque specified in the repair, maintenance or installation procedure overrides the standard torque.

#### Oil-lubricated screws with allen head screws

The following table specifies the recommended standard tightening torque for *oil-lubricated screws with allen head screws*.



#### Note

A special torque specified in the repair, maintenance or installation procedure overrides the standard torque.

Dimension	Tightening torque (Nm)	Tightening torque (Nm)	Tightening torque (Nm)
	Class 8.8, oil-lubricated	Class 10.9, oil-lubricated	Class 12.9, oil-lubricated
M5	6	-	-
M6	10	-	-
M8	24	34	40
M10	47	67	80
M12	82	115	140
M16	200	290	340
M20	400	560	670

Continues on next page

## 7 Reference information

### 7.4 Screw joints

Continued

Dimension	Tightening torque (Nm) Class 8.8, oil-lubricated	Tightening torque (Nm) Class 10.9, oil-lubricated	Tightening torque (Nm) Class 12.9, oil-lubricated
M24	680	960	1150

Lubricated screws (Molykote, Gleitmo or equivalent) with allen head screws

The following table specifies the recommended standard tightening torque for *screws lubricated with Molykote 1000, Gleitmo 603 or equivalent with allen head screws.*



#### Note

A special torque specified in the repair, maintenance or installation procedure overrides the standard torque.

Dimension	Tightening torque (Nm) Class 10.9, lubricated <sup>i</sup>	Tightening torque (Nm) Class 12.9, lubricated <sup>i</sup>
M8	28	35
M10	55	70
M12	96	120
M16	235	300
M20	460	550
M24	790	950

<sup>i</sup> Lubricated with Molykote 1000, Gleitmo 603 or equivalent



## 7.5 Weight specifications

### Definition

In installation, repair, and maintenance procedures, weights of the components handled are sometimes specified. All components exceeding 22 kg (50 lbs) are highlighted in this way.

To avoid injury, ABB recommends the use of a lifting accessory when handling components with a weight exceeding 22 kg. A wide range of lifting accessories and devices are available for each manipulator model.

### Example

Following is an example of a weight specification in a procedure:

	Action	Note
	 <b>CAUTION</b> The arm weighs 25 kg. All lifting accessories used must be sized accordingly.	

## 7 Reference information

---

### 7.6 Standard tools

### 7.6 Standard tools

---

#### General

All service (repairs, maintenance, and installation) procedures contains lists of tools required to perform the specified activity.

All special tools required are listed directly in the procedures while all the tools that are considered standard are gathered in the standard toolkit and defined in the following table.

This way, the tools required are the sum of the standard toolkit and any tools listed in the instruction.

---

#### Contents, standard toolkit

Qty	Tool
1	Ring-open-end spanner 8-19 mm
1	Socket head cap 2.5-17 mm
1	Torx socket no: 20-60
1	Torque wrench 10-100 Nm
1	Small screwdriver
1	Plastic mallet
1	Ratchet head for torque wrench 1/2"
1	Socket head cap no: 5, socket 1/2" bit L 20 mm
1	Socket head cap no: 6, socket 1/2" bit L 20 mm
1	Socket head cap no: 8, socket 1/2" bit L 20 mm
1	Small cutting plier
1	T-handle with ball head

## 7.7 Special tools

### General

All service instructions contain lists of tools required to perform the specified activity. The required tools are a sum of standard tools, defined in the section [Standard tools on page 398](#), and of special tools, listed directly in the instructions and also gathered in this section.

### Measuring tools, play

The tools listed for measuring the play are used after service work on axes 5 and 6.

Description	Robot variant	Art. no.
Measuring tool, play	IRB 4600 - 60/2.05, -45/2.05, -40/2.55	3HAB1611-6
Measuring tool, play	IRB 4600 - 20/2.50	3HAB6337-1

### Special tools

The following table specifies the special tools required during several of the service procedures. The tools may be ordered separately and are also specified directly in concerned instructions in the product manual.

Description	Qty	Art. no.
Guide pins, removal/refitting of axis 1 gearbox	2 pcs	-
Guide pins, removal/refitting of axis 3 gearbox	2 pcs	-

### Oil change equipment

The following table specifies the oil change equipment. The tool is specified directly in concerned instructions in the product manual.

Description	Included parts	Art. no.
Oil change equipment	<ul style="list-style-type: none"> <li>• vacuum pump with regulator, hose and coupling</li> <li>• couplings and adapters</li> <li>• pump (manual) with hose and coupling</li> <li>• graduated measuring glass</li> <li>• oil gun</li> <li>• user instructions.</li> </ul>	3HAC021745-001

### Calibration equipment, Levelmeter (alternative method)

The following table specifies the calibration equipment required when calibrating the robot with the alternative method, Levelmeter Calibration.

Description	Art. no.	Note
Angle bracket	68080011-LP	
Calibration bracket	3HAC13908-9	

*Continues on next page*

## 7 Reference information

### 7.7 Special tools

*Continued*

Description	Art. no.	Note
Calibration tool ax1	3HAC13908-4	
Measuring pin	3HAC13908-5	
Sensor fixture	68080011-GM	
Sensor plate	3HAC0392-1	
Sync. adapter	3HAC13908-1	

#### Calibration equipment, Calibration Pendulum

The following table specifies the calibration equipment needed when calibrating the robot with the Calibration Pendulum method.

The robot is calibrated by either Calibration Pendulum or Axis Calibration at factory. Always use the same calibration method as used at the factory.

Information about valid calibration method is found on the calibration label or in the calibration menu on the FlexPendant.

If no data is found related to standard calibration, Calibration Pendulum is used as default.

Description	Art. no.	Note
Calibration Pendulum toolkit	3HAC15716-1	Complete kit that also includes operating manual.

#### Calibration equipment, Axis Calibration

The following table specifies the calibration equipment needed when calibrating the robot with the Axis Calibration method.

The robot is calibrated by either Calibration Pendulum or Axis Calibration at factory. Always use the same calibration method as used at the factory.

Information about valid calibration method is found on the calibration label or in the calibration menu on the FlexPendant.

If no data is found related to standard calibration, Calibration Pendulum is used as default.

Description	Art. no.	Note
Calibration tool box, Axis Calibration	3HAC074119-001	Delivered as a set of calibration tools. Required if Axis Calibration is the valid calibration method for the robot. Contains a removal tool for removing special protection plugs on the turning disk.

#### Turning tool for suspended mounting

The following table specifies the lifting tool required when fitting the robot in a suspended position.

Description	Art. no.	Note
Turning tool (includes lifting instruction)	3HAC034766-001	Valid for other designs than Type B, C and Type D.

*Continues on next page*

Description	Art. no.	Note
Turning tool (includes lifting instruction 3HAC051688-001)	3HAC048502-001	Valid for Types B, D and Type D.

### Lifting accessories

This table specifies the lifting accessories required during several of the service procedures. The lifting accessories can be ordered separately and are also specified directly in concerned instructions.

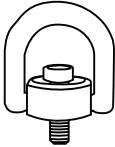
Description	Qty	Article no.	Note
Lifting accessory, axis 2			
Lifting accessory, axis 3			
Rotating lifting point	2 pcs	-	<p>For lifting of upper arm. Dimension: M8. Example: Gunnebo RLP GrabiQ M8-10.</p>  <p>xx1100000564</p>

### Special tools

This table specifies the special tools required during several of the service procedures. The tools are specified directly in concerned instructions.

Description	Qty	Article no.
Guide for reduction gear	1	3HACxxx Used to guide axis-1 gear and frame during refitting.

## 7 Reference information

---

### 7.8 Lifting accessories and lifting instructions

### 7.8 Lifting accessories and lifting instructions

---

#### General

Many repair and maintenance activities require different pieces of lifting accessories, which are specified in each procedure.

The use of each piece of lifting accessories is *not* detailed in the activity procedure, but in the instruction delivered with each piece of lifting accessories.

The instructions delivered with the lifting accessories should be stored for later reference.

## 8 Spare part lists

### 8.1 Spare part lists and illustrations

#### Location

Spare parts and exploded views are not included in the manual but delivered as a separate document for registered users on myABB Business Portal, [www.abb.com/myABB](http://www.abb.com/myABB).



#### Tip

All documents can be found via myABB Business Portal, [www.abb.com/myABB](http://www.abb.com/myABB).

**This page is intentionally left blank**



## 9 Circuit diagram

### 9.1 Circuit diagrams

#### Overview

The circuit diagrams are not included in this manual, but are available for registered users on myABB Business Portal, [www.abb.com/myABB](http://www.abb.com/myABB).

See the article numbers in the tables below.

#### Controllers

Product	Article numbers for circuit diagrams
<i>Circuit diagram - OmniCore V250XT</i>	<i>3HAC074000-008</i>
<i>Circuit diagram - IRC5</i>	<i>3HAC024480-011</i>
<i>Circuit diagram - IRC5 Panel Mounted Controller</i>	<i>3HAC026871-020</i>
<i>Circuit diagram - Euromap 67, design 14</i>	<i>3HAC024120-005</i>
<i>Circuit diagram - Spot welding cabinet</i>	<i>3HAC057185-001</i>

#### Manipulators

Product	Article numbers for circuit diagrams
<i>Circuit diagram - IRB 120</i>	<i>3HAC031408-003</i>
<i>Circuit diagram - IRB 140 type C</i>	<i>3HAC6816-3</i>
<i>Circuit diagram - IRB 260</i>	<i>3HAC025611-001</i>
<i>Circuit diagram - IRB 360</i>	<i>3HAC028647-009</i>
<i>Circuit diagram - IRB 460</i>	<i>3HAC036446-005</i>
<i>Circuit diagram - IRB 660</i>	<i>3HAC025691-001</i>
<i>Circuit diagram - IRB 760</i>	<i>3HAC025691-001</i>
<i>Circuit diagram - IRB 1200</i>	<i>3HAC046307-003</i>
<i>Circuit diagram - IRB 1410</i>	<i>3HAC2800-3</i>
<i>Circuit diagram - IRB 1600/1660</i>	<i>3HAC021351-003</i>
<i>Circuit diagram - IRB 1520</i>	<i>3HAC039498-007</i>
<i>Circuit diagram - IRB 2400</i>	<i>3HAC6670-3</i>
<i>Circuit diagram - IRB 2600</i>	<i>3HAC029570-007</i>
<i>Circuit diagram - IRB 4400/4450S</i>	<i>3HAC9821-1</i>
<i>Circuit diagram - IRB 4600</i>	<i>3HAC029038-003</i>
<i>Circuit diagram - IRB 6620</i>	<i>3HAC025090-001</i>
<i>Circuit diagram - IRB 6620 / IRB 6620LX</i>	<i>3HAC025090-001</i>
<i>Circuit diagram - IRB 6640</i>	<i>3HAC025744-001</i>
<i>Circuit diagram - IRB 6650S</i>	<i>3HAC13347-1</i> <i>3HAC025744-001</i>

*Continues on next page*

## 9 Circuit diagram

---

### 9.1 Circuit diagrams

*Continued*

<b>Product</b>	<b>Article numbers for circuit diagrams</b>
<i>Circuit diagram - IRB 6660</i>	<i>3HAC025744-001 3HAC029940-001</i>
<i>Circuit diagram - IRB 6700 / IRB 6790</i>	<i>3HAC043446-005</i>
<i>Circuit diagram - IRB 7600</i>	<i>3HAC13347-1 3HAC025744-001</i>
<i>Circuit diagram - IRB 14000</i>	<i>3HAC050778-003</i>
<i>Circuit diagram - IRB 910SC</i>	<i>3HAC056159-002</i>

# Index

## A

- Absolute Accuracy, calibration, 356
- air quality, 43
- allergenic material, 30
- aluminum
  - disposal, 388
- ambient humidity
  - operation, 50
  - storage, 49
- ambient temperature
  - operation, 50
  - storage, 49
- assembly instructions, 41
- assessment of hazards and risks, 30
- Axis Calibration, 367
  - calibration tool
    - article number, 370, 374
    - examining, 370
    - installation position, 372
  - overview of method, 367
  - procedure on FlexPendant, 374, 382
  - protective cover and protection plug, 372, 374

## B

- batteries
  - disposal, 388
- battery pack
  - replacing, interval, 113
- brakes
  - testing function, 38

## C

- cabinet lock, 31
- cabling, robot, 93
- cabling between robot and controller, 93
- calibrating
  - robot, 367
  - roughly, 361, 365
- calibrating robot, 367, 381–382
- calibration
  - Absolute Accuracy type, 354
  - rough, 361, 365
  - standard type, 354
  - verification, 384
  - when to calibrate, 357
- calibration, Absolute Accuracy, 356
- calibration manuals, 356
- calibration marks, 358
- Calibration Pendulum
  - overview of method, 381
- calibration position
  - jogging to, 385–386
  - scales, 358
- calibration scales, 358
- CalibWare, 354
- carbon dioxide extinguisher, 31
- cast iron
  - disposal, 388
- cleaners
  - approved, 191
  - requirements, 191
- cleaning, 189
- climbing on robot, 34
- Cold environments, 92

- connecting the robot and controller, cabling, 93
- copper
  - disposal, 388

## D

- detergents
  - approved, 191
  - requirements, 191
- direction of axes, 360

## E

- environmental information, 388
- ESD
  - damage elimination, 56
  - sensitive equipment, 56
- expansion container
  - installing, 86
- expected life, 114

## F

- fire extinguishing, 31
- FlexPendant
  - jogging to calibration position, 385–386
  - MoveAbsJ instruction, 385–386
  - updating revolution counters, 362, 365
- foundation
  - requirements, 49

## G

- gearboxes
  - location of, 151
- Gravity Alpha, 62
- Gravity Beta, 61
- grease, 34
  - disposal, 388

## H

- hanging
  - installed hanging, 30
- hazard levels, 21
- hazardous material, 388
- height
  - installed at a height, 30
- hot surfaces, 34
- HRA, 30
- humidity
  - operation, 50
  - storage, 49

## I

- instructions for assembly, 41
- integrator responsibility, 30
- intervals for maintenance, 112

## L

- labels
  - robot, 23
- leak-down test, 194
- lifting
  - accessory, 60
- lifting accessory, 397
- limitation of liability, 19
- Lithium
  - disposal, 388
- loads on foundation, 48
- lock and tag, 31
- lubricants, 34

- lubrication
  - amount in gearboxes, 151
  - type of lubrication, 151
- M**
- magnesium
  - disposal, 388
- maintenance schedule, 112
- MoveAbsJ instruction, 385–386
- N**
- national regulations, 30
- negative directions, axes, 360
- neodymium
  - disposal, 388
- nodular iron
  - disposal, 388
- O**
- oil, 34
  - amount in gearboxes, 151
  - disposal, 388
  - type of oil, 151
- oil change
  - axis 1, floor mounted robots, 153
  - axis 1, suspended robots, 160
  - axis 2, 165
  - axis 3, 169
  - axis 4, 175
  - axis 5, 179
  - axis 6, 179
- operating conditions, 50
- options
  - expansion container, 86
- original spare parts, 19
- P**
- paint surface damage, 150
- pedestal
  - installed on pedestal, 30
- personnel
  - requirements, 20
- plastic
  - disposal, 388
- positive directions, axes, 360
- PPE, 20
- pressurized components
  - air quality, 43
  - Foundry Prime, 42
- product standards, 392
- protection classes, 50
- protection type, 50
- protective equipment, 20
- protective wear, 20
- R**
- recycling, 388
- regional regulations, 30
- release brakes, 37
- repair
  - painted surface, 150
- replacements, report, 193
- replacing
  - xx, 143
- report replacements, 193
- requirements on foundation, 49
- responsibility and validity, 19
- revolution counters
  - storing on FlexPendant, 362, 365
  - updating, 361, 365
- risk of burns, 34
- risk of tipping, 55
- robot
  - labels, 23
  - protection class, 50
  - protection types, 50
  - symbols, 23
- rubber
  - disposal, 388
- S**
- safety
  - brake testing, 38
  - ESD, 56
  - fire extinguishing, 31
  - release robot axes, 37
  - signals, 21
  - signals in manual, 21
  - symbols, 21
  - symbols on robot, 23
  - test run, 107
- safety devices, 31
- safety hazard
  - hydraulic system, 32
  - pneumatic system, 32
- safety signals
  - in manual, 21
- safety standards, 392
- scales on robot, 358
- schedule for maintenance, 112
- screw joints, 394
- sensitive points
  - Foundry Prime, 45
- shut-down, 46
- signals
  - safety, 21
- special tools, 399
- speed
  - adjusting, 92
- stability, 55
- standards, 392
  - ANSI, 392
  - CAN, 392
- start of robot in cold environments, 92
- steel
  - disposal, 388
  - storage conditions, 49
  - suspended mounting, 61
- symbols
  - safety, 21
- synchronization position, 361, 365
- sync marks, 358
- system integrator requirements, 30
- system parameter
  - Gravity Alpha, 62
  - Gravity Beta, 61
- T**
- temperatures
  - operation, 50
  - storage, 49
- testing
  - brakes, 38
- tools

Axis Calibration, 400  
calibration equipment, Levelmeter, 399  
Calibration Pendulum, 400  
for service, 399  
torques on foundation, 48  
troubleshooting  
oil spills, 189  
safety, 39  
turning  
accessory, 60

**U**

upcycling, 388  
updating revolution counters, 361, 365  
users  
requirements, 20

**V**

validity and responsibility, 19  
velocity

adjusting, 92  
verifying calibration, 384

**W**

weight, 47  
base, 261–262  
robot, 58, 70, 259, 279–280, 285, 287, 297–298, 329,  
333, 339, 341, 347–349  
upper and lower arm, 338, 342  
upper arm, complete, 269, 273  
Wrist Optimization  
overview of method, 382

**X**

xx  
replacing, 143

**Z**

zero position  
checking, 385







**ABB AB**

**Robotics & Discrete Automation**

S-721 68 VÄSTERÅS, Sweden

Telephone +46 (0) 21 344 400

**ABB AS**

**Robotics & Discrete Automation**

Nordlysvegen 7, N-4340 BRYNE, Norway

Box 265, N-4349 BRYNE, Norway

Telephone: +47 22 87 2000

**ABB Engineering (Shanghai) Ltd.**

Robotics & Discrete Automation

No. 4528 Kangxin Highway

PuDong New District

SHANGHAI 201319, China

Telephone: +86 21 6105 6666

**ABB Inc.**

**Robotics & Discrete Automation**

1250 Brown Road

Auburn Hills, MI 48326

USA

Telephone: +1 248 391 9000

**[abb.com/robotics](http://abb.com/robotics)**